

2007 ELECTRICAL

Charging System (MZI-3.5) - CX-9

CHARGING SYSTEM LOCATION INDEX [MZI-3.5]

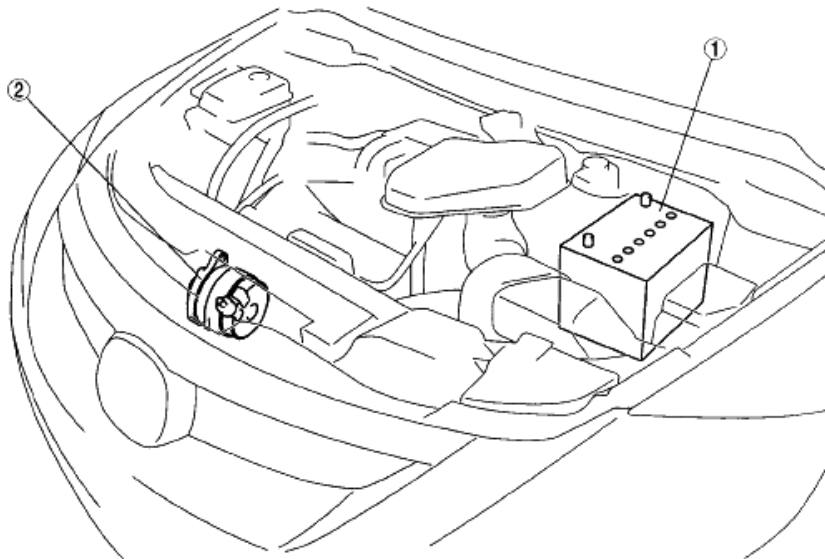

ac9uuw000c2172

1	Battery (See [MZI-3.5].) (See [MZI-3.5].) (See [MZI-3.5].)	BATTERY REMOVAL/INSTALLATION BATTERY INSPECTION [MZI-3.5]. BATTERY RECHARGING [MZI-3.5].
---	---	--

2	Generator (See [MZI-3.5].) (See [MZI-3.5].) (See [MZI-3.5].)	GENERATOR REMOVAL/ INSTALLATION [MZI-3.5]. GENERATOR INSPECTION [MZI- 3.5]. GENERATOR DISASSEMBLY/ ASSEMBLY [MZI-3.5].
---	---	---

Fig. 1: Identifying Battery And Generator Location

Courtesy of MAZDA MOTORS CORP.

BATTERY REMOVAL/INSTALLATION [MZI-3.5]

1. Remove in the order indicated in the table.
2. Install in the reverse order of removal.

2007 Mazda CX-9 Grand Touring

2007 ELECTRICAL Charging System (MZI-3.5) - CX-9

1	Negative battery cable
2	Positive battery cable
3	Battery clamp
4	Battery box (See Battery Box Installation Note.)
5	Battery
6	Battery tray

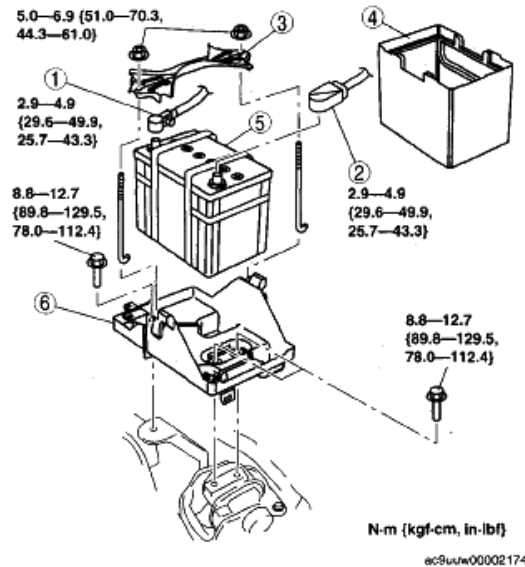
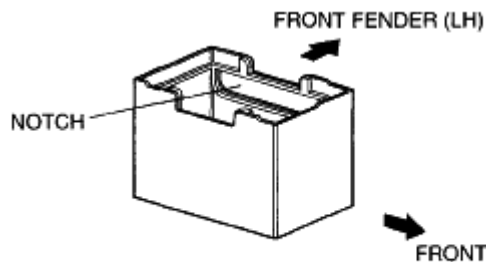

Fig. 2: Identifying Battery Components With Torque Specifications
Courtesy of MAZDA MOTORS CORP.

BATTERY BOX INSTALLATION NOTE

1. Install the battery box so that the side with the notch points toward the front fender (LH).



ac9uuw00002175

Fig. 3: Identifying Battery Box
Courtesy of MAZDA MOTORS CORP.

BATTERY INSPECTION [MZI-3.5]

WARNING:

- Since battery acid is toxic, be careful when handling the battery.
- Since battery acid is highly corrosive, be careful not to allow it to contact clothing or the vehicle.
- In case battery acid contacts skin, eyes, or clothing, flush it immediately with running water. Especially if the acid gets in the eyes, flush with water for more than 15 min and get prompt medical attention.

2007 Mazda CX-9 Grand Touring

2007 ELECTRICAL Charging System (MZI-3.5) - CX-9

ELECTROLYTE SPECIFIC GRAVITY

1. Measure the electrolyte specific gravity using a hydrometer.
 - If it is less than the specification, recharge the battery. (See **BATTERY RECHARGING [MZI-3.5]**.)

Battery electrolyte specific gravity [20 °C {68 °F}]

1.22-1.29

BATTERY VOLTAGE

1. Inspect the battery as follows:

DIAGNOSIS PROCEDURE

Step	Inspection		Action
1	Measure the battery positive voltage.	12.4 V or more	Go to Step 3.
		Less than 12.4 V	Go to the next step.
2	Quick charge for 30 min and recheck voltage.	12.4 V or more	Go to the next step.
		Less than 12.4 V	Replace the battery.
3	Using the battery load tester, apply load current (80D26L (55): 195 A) and record battery voltage after 15 s . Is voltage more than the specification?	Yes	Normal
		No	Replace the battery.

Battery load test current

80D26L (55): 195 A

Standard specification

BATTERY SPECIFICATION

Battery temp. (°C {°F})	Minimum voltage (V)
4 {39}	9.3
10 {50}	9.4
16 {61}	9.5
21 {70}	9.6

BACK-UP CURRENT

1. Verify that the ignition switch is off (key has been removed) and that all doors are closed.

2007 Mazda CX-9 Grand Touring

2007 ELECTRICAL Charging System (MZI-3.5) - CX-9

2. Disconnect the negative battery cable.
3. Connect the tester between the negative battery terminal and negative battery cable, leave the battery undisturbed for **30 min** , and then measure the back-up current.
 - If not within the specification, measure the back-up current while removing the fuses one by one from the inside of the main fuse block and the inside of the fuse block.

NOTE:

- If the battery is not left undisturbed for 30 min , the tester will indicate a high value (approx. 300 mA).
- If the key or any electrical accessory is operated within approx. 30 min after the tester is connected, the battery must be left undisturbed for approx. 30 min from that point.

CAUTION:

- Operating electrical loads while the back-up current is being measured can damage the tester.

NOTE:

- For vehicles with the immobilizer system, the system periodically shifts synchronization of the security light flashing. Therefore, 60 mA (0.1 s) current is supplied when the security light is illuminated, and 50 mA (2 s) current is supplied when the security light is not illuminated. In addition, the measuring instrument, which shows the average value, indicates around 55 mA .

Battery back-up current

Vehicles with immobilizer system: 50-60 mA

Vehicles without immobilizer system: 55 mA or less

4. Inspect and repair wiring harnesses and connectors of the fuse where the current has decreased.

BATTERY RECHARGING [MZI-3.5]

WARNING:

- Keep all flames away from the battery, otherwise evaporated gas from the battery fluid may catch fire, and cause serious injury.
- Remove the battery filler caps when recharging to prevent battery deformation or damage.

CAUTION:

- Do not quick charge for more than 30 min. It will damage the battery.

1. Remove the battery and then place it in a pan of water.
2. Remove the battery filler caps.

3. Connect a battery charger to the battery and adjust the charging current as follows.

Battery slow charge current

80D26L (55): 5.5-6.5 A

Battery quick charge current [30 min]

80D26L (55): 35 A

4. After the battery is recharged, verify that the voltage is within the specification and remains at the same value for **1 h or more** after the recharging has been completed.
 - If not within the specification, replace the battery.

Standard voltage

12.4 V or more

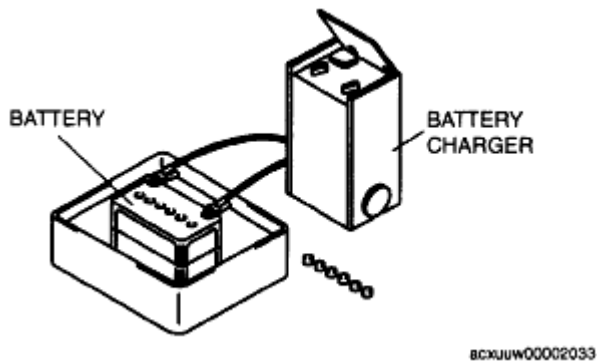

Fig. 4: Connecting Battery Charger To Battery
Courtesy of MAZDA MOTORS CORP.

GENERATOR REMOVAL/INSTALLATION [MZI-3.5]

WARNING:

- Remove and install all parts when the engine is cold, otherwise they can cause severe burns or serious injury.
- When the battery cables are connected, touching the vehicle body with generator terminal B will generate sparks. This can cause personal injury, fire, and damage to the electrical components. Always disconnect the negative battery cable before performing the following operation.

1. Disconnect the negative battery cable.
2. Drain the engine coolant. (see **ENGINE COOLANT REPLACEMENT [MZI-3.5]** .)
3. Remove the air cleaner and fresh air duct component. (see **INTAKE-AIR SYSTEM**

REMOVAL/INSTALLATION [MZI-3.5] .)

4. Remove the cooling fan component. (see **FAN MOTOR REMOVAL/INSTALLATION [MZI-3.5] .)**
5. Remove the front splash shield (RH).
6. Remove the generator and A/C drive belt. (see **DRIVE BELT REMOVAL/INSTALLATION [MZI-3.5] .)**
7. Remove in the order indicated in the table.
8. Install in the reverse order of removal.
9. Refill the engine coolant. (see **ENGINE COOLANT REPLACEMENT [MZI-3.5] .)**
10. Inspect for engine coolant leakage. (see **ENGINE COOLANT LEAKAGE INSPECTION [MZI-3.5] .)**

1	Terminal B cable
2	Generator connector
3	Generator lower bolt (See Generator Lower Bolt Removal Note.)
4	Generator (See Generator Removal Note.) (See Generator Installation Note.)

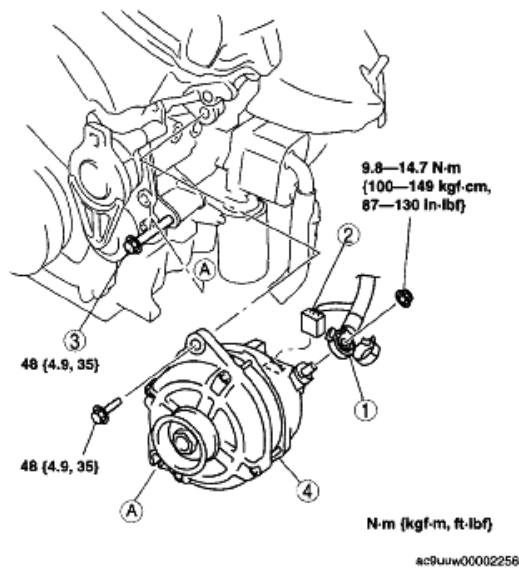

Fig. 5: Identifying Generator And Connector With Torque Specifications
 Courtesy of MAZDA MOTORS CORP.

GENERATOR LOWER BOLT REMOVAL NOTE

NOTE:

- The generator lower bolt cannot be fully removed from the engine because it contacts the body frame. However, the generator can be removed/installed without fully removing the lower bolt because there is a notch at the lower bolt installation part of the generator.

1. Fully loosen the generator lower bolt.

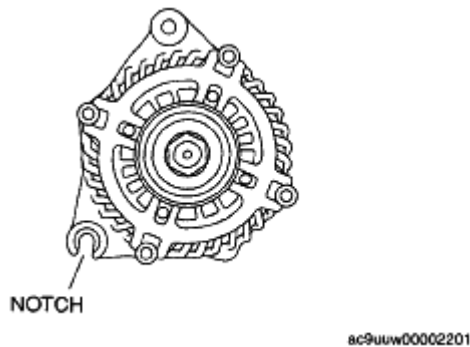

Fig. 6: Identifying Generator Lower Bolt
Courtesy of MAZDA MOTORS CORP.

GENERATOR REMOVAL NOTE

1. Remove the generator from above the engine compartment.

GENERATOR INSTALLATION NOTE

1. Tighten the upper and lower bolts temporarily.
2. Tighten the upper bolt to the specified tightening torque.
3. Tighten the lower bolt to the specified tightening torque.

GENERATOR INSPECTION [MZI-3.5]

GENERATOR WARNING LIGHT

1. Verify that the battery is fully charged.
2. Verify that the generator and A/C drive belt deflection/tension is correct. (see **DRIVE BELT INSPECTION [MZI-3.5]** .)
3. With the ignition switch turned to the ON position, verify that the generator warning light illuminates.
 - If it does not illuminate, inspect the generator warning light and the wiring harness.
 - If the generator warning light and the wiring harness are normal, inspect the PCM.
4. Verify that the generator warning light goes out after the engine is started.
 - If it does not go out, inspect if any DTCs are displayed.
 - If any DTCs are displayed, carry out troubleshooting according to the corresponding DTC inspection.

GENERATOR

Voltage

1. Verify that the battery is fully charged.
2. Verify that the generator and A/C drive belt deflection/tension is correct. (see **DRIVE BELT**

INSPECTION [MZI-3.5] .)

3. Turn off all electrical loads.
4. Start the engine.
5. Verify that the generator rotates smoothly without any noise while the engine is running.
 - If there is any noise, find the cause and repair or replace the generator.
6. Measure the voltage at each terminal using a tester.
 - If it is not as specified, find the cause and repair or replace the applicable part.

Generator standard voltage [IG-ON]

Terminal B: B+

Terminal A: B+

Terminal RC: Approx. 1 V or less

Terminal LI: Approx. 1 V

Generator standard voltage [Idle, 20 °C {68 °F}]

Terminal B: 12-16 V

Terminal A: 12-16 V

Terminal RC: 0-16 V

Terminal LI: 1-16 V

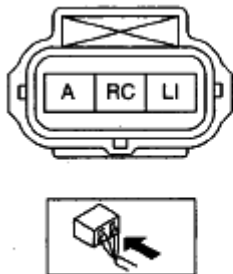

ac9uuw00002202

Fig. 7: Identifying Generator Connector Terminals

Courtesy of MAZDA MOTORS CORP.

Current

NOTE:

- Since the charging current decreases rapidly after starting the engine, carry out the following procedure quickly, and read the maximum current

2007 Mazda CX-9 Grand Touring

2007 ELECTRICAL Charging System (MZI-3.5) - CX-9

value.

1. Verify that the battery is fully charged.
2. Verify that the generator and A/C drive belt deflection/tension is correct. (see **DRIVE BELT INSPECTION [MZI-3.5]** .)
3. Disconnect the negative battery cable.
4. Connect a tester, which can read **120 A or more** , between generator terminal B and the wiring harness.
5. Connect the negative battery cable.
6. Turn off all electrical loads.
7. Start the engine.
8. Increase engine speed to **2,500 rpm**.

NOTE:

- **When the electrical load on the vehicle is low, the specified current cannot be verified although the generator is normal. In this case, increase the electrical load (Leave the headlights turned on for a while, then discharge the battery, or use a similar method.) and recheck.**
 - **When the generator itself or the ambient temperature are too high, the specified current also cannot be verified. In this case, cool down the generator and recheck.**
9. Turn the following electrical loads on and verify that the current reading increases more than the minimum value indicated below.
 - Headlights (high-beam)
 - Blower motor (HI)
 - Rear window defroster
 - Brake lights

Generator generated current minimum value

70 % of the nominal output current (nominal output current: 110 A)

[Ambient temp. 20 °C {68 °F}, voltage 13.0-15.0 V, both engine and generator are hot]

GENERATOR INNER PARTS

Rotor

1. Measure the resistance between the slip rings using a tester.
 - If not within the specification, replace the rotor.

Generator rotor resistance (between slip rings) [20 °C {68 °F}]

1.8-2.2 ohm

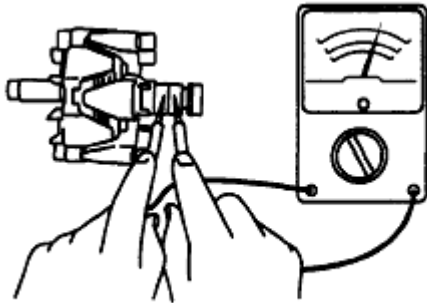

8CKUJW00002021

Fig. 8: Measuring Resistance Between Slip Rings Using With Tester
Courtesy of MAZDA MOTORS CORP.

2. Verify that there is no continuity between the slip ring and core using a tester.
 - If there is continuity, replace the rotor.
3. Inspect the slip ring surface condition.
 - If the slip ring surface is rough, use a lathe or fine sandpaper to smooth it.

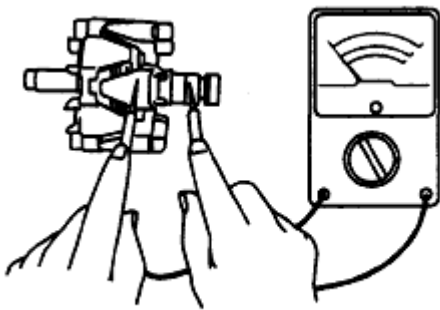

8CKUJW00002022

Fig. 9: Measuring Continuity Between Slip Ring And Core Using With Tester
Courtesy of MAZDA MOTORS CORP.

Stator coil

1. Verify that the continuity is as indicated in the table.

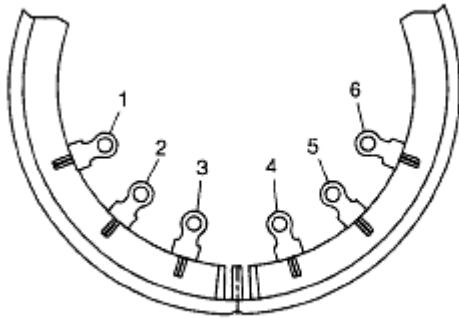

acxuuw00002023

Fig. 10: Identifying Stator Coil Connector Terminals
 Courtesy of MAZDA MOTORS CORP.

- If there is any malfunction, replace the stator.

○—○ : Continuity

Terminal					
1	2	3	4	5	6
○—○					
○—○	○—○				
	○—○				
			○—○		
			○—○	○—○	
				○—○	

acxuuw00002024

Fig. 11: Terminals Continuity Chart
 Courtesy of MAZDA MOTORS CORP.

2. Verify that there is no continuity between the stator coil leads and core using a tester.
 - If there is continuity, replace the stator coil.

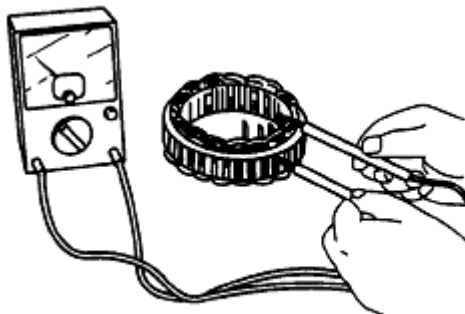

acxuuw00002025

Fig. 12: Measuring Continuity Between Stator Coil Leads And Core Using Tester
 Courtesy of MAZDA MOTORS CORP.

1. Inspect brushes for wear.
 - If any brush is worn almost to or beyond the limit, replace all of the brushes.

Generator brush length

Standard: 22.5 mm {0.89 in}

Minimum: 5.0 mm {0.20 in}

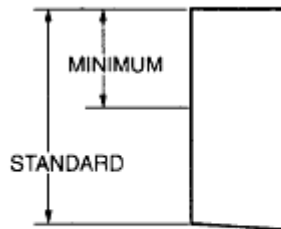

acxuuw00002026

Fig. 13: Identifying Generator Brush Length
Courtesy of MAZDA MOTORS CORP.

Brush spring

1. Measure the force of the brush spring using a spring pressure gauge.
2. Read the spring pressure gauge at the brush tip projection of **2 mm {0.079 in}**.
 - Replace the brush spring if necessary.

Generator brush spring force

Standard: 4.1-5.3 N {0.42-0.54 kgf, 0.92-1.19 lbf}

Minimum: 1.7 N {0.17 kgf, 0.38 lbf}

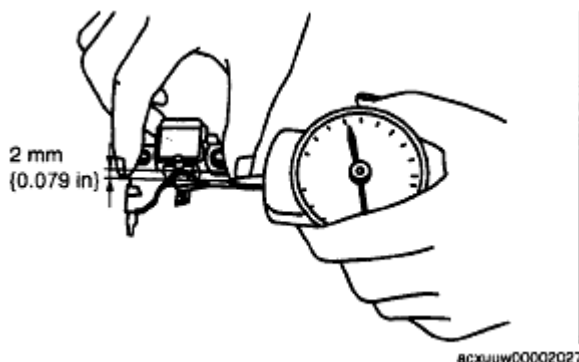

acxuuw00002027

Fig. 14: Measuring Force Of Brush Spring Using Spring Pressure Gauge

Courtesy of MAZDA MOTORS CORP.

Rectifier (Using an analog circuit tester)

1. Inspect for continuity of the diodes using an analog circuit tester.
 - If not as specified, replace the rectifier.

Specification

TERMINALS CONTINUITY CHART

Negative	Positive	Continuity
E	P1, P2, P3, P4, P5, P6	Yes
B		No
P1, P2, P3, P4, P5, P6	E	No
	B	Yes

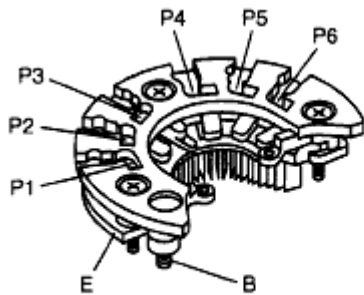

8CXUJW00002028

Fig. 15: Identifying Rectifier Connector
Courtesy of MAZDA MOTORS CORP.

Rectifier (Using a digital circuit tester)

1. Inspect for continuity of the diodes using a digital circuit tester.
 - If not as specified, replace the rectifier.

Specification

TERMINALS CONTINUITY CHART

Negative	Positive	Continuity
E	P1, P2, P3, P4, P5, P6	No
B		Yes
P1, P2, P3, P4, P5, P6	E	Yes
	B	No

Bearing

1. Inspect for abnormal noise, looseness, and sticking.
 - Replace the bearing if necessary.

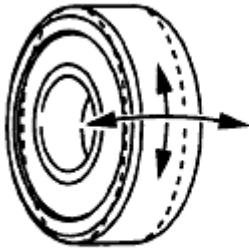

acxuuw00002029

Fig. 16: Inspecting Bearing For Abnormal Noise, Looseness And Sticking
Courtesy of MAZDA MOTORS CORP.

GENERATOR DISASSEMBLY/ASSEMBLY [MZI-3.5]

- CAUTION:**
- Melt the solder quickly, otherwise the diodes (rectifier) and regulator will be damaged by excessive heat.

1. Disassemble in the order indicated in the table.
2. Assemble in the reverse order of disassembly.

2007 Mazda CX-9 Grand Touring

2007 ELECTRICAL Charging System (MZI-3.5) - CX-9

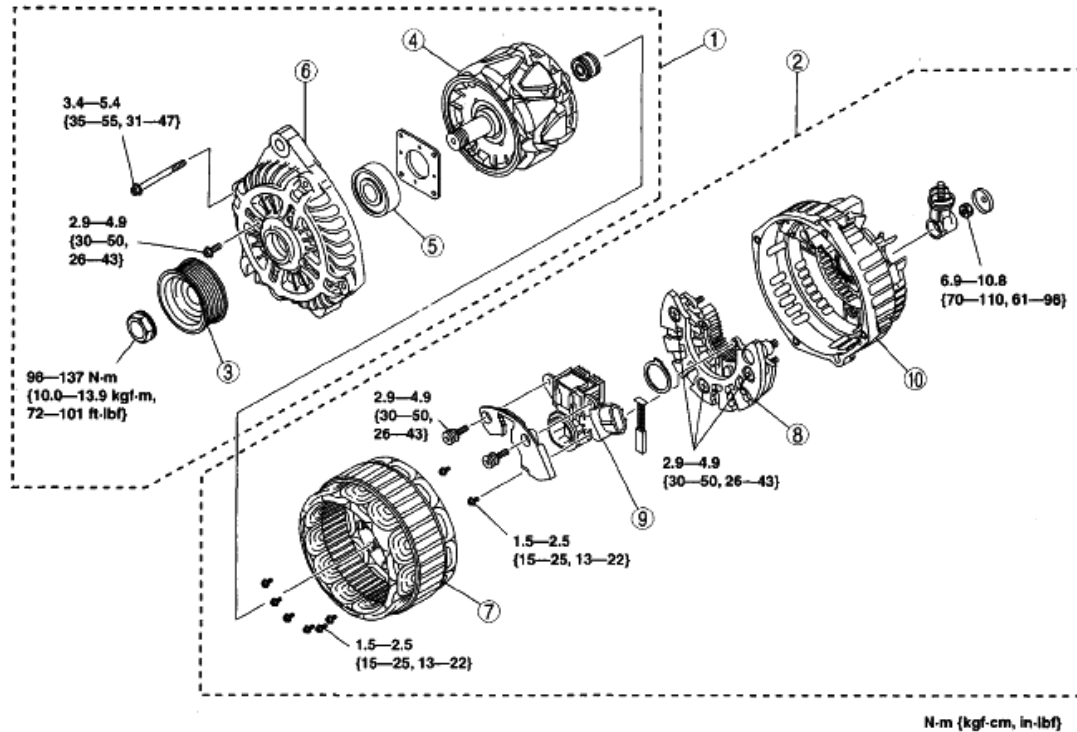

ac9uuw0002173

1	Rotor component
2	Stator coil component
3	Pulley
4	Rotor
5	Front bearing

6	Front cover
7	Stator coil
8	Rectifier
9	Brush holder
10	Rear cover

Fig. 17: Exploded View Of Generator With Torque Specifications
 Courtesy of MAZDA MOTORS CORP.