

**2007 Mazda CX-9 Grand Touring**

2007 ENGINE PERFORMANCE Control System (MZI-3.5) - CX-9

**2007 ENGINE PERFORMANCE**

**Control System (MZI-3.5) - CX-9**

**CONTROL SYSTEM LOCATION INDEX [MZI-3.5]**

# 2007 Mazda CX-9 Grand Touring

## 2007 ENGINE PERFORMANCE Control System (MZI-3.5) - CX-9

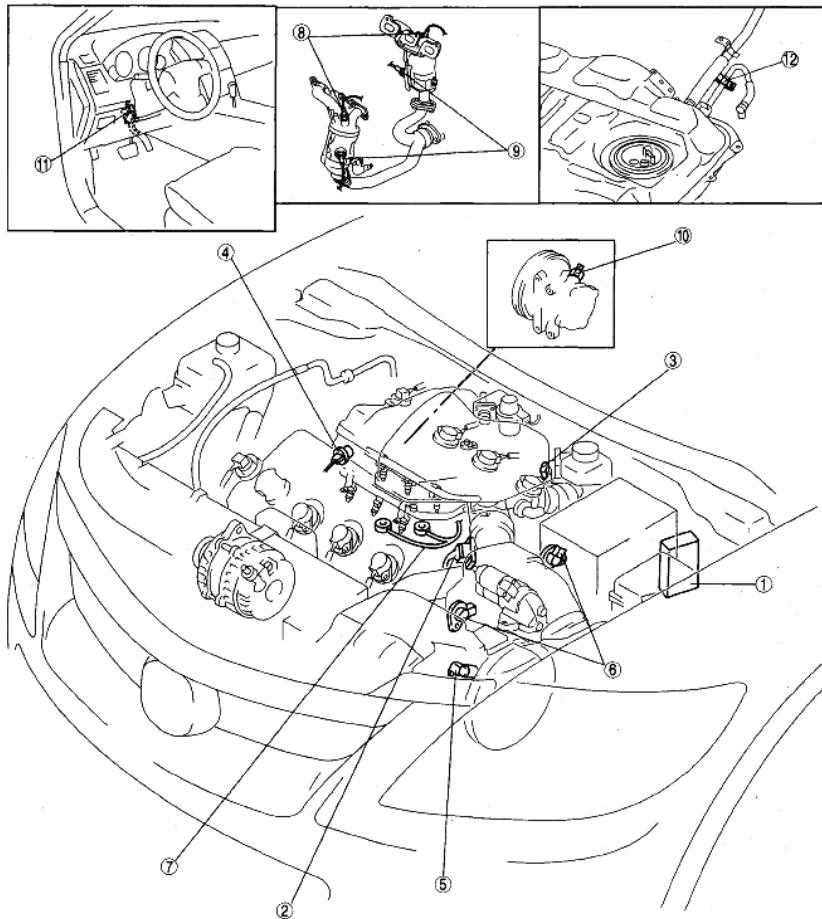

ac80uw00001132

1	PCM (See PCM REMOVAL/INSTALLATION [MZI-3.5].) (See PCM INSPECTION [MZI-3.5].) (See PCM CONFIGURATION [MZI-3.5].)
2	MAF/IAT sensor (See MASS AIR FLOW (MAF)/INTAKE AIR TEMPERATURE (IAT) SENSOR REMOVAL/INSTALLATION [MZI-3.5].) (See MASS AIR FLOW (MAF) SENSOR INSPECTION [MZI-3.5].) (See INTAKE AIR TEMPERATURE (IAT) SENSOR INSPECTION [MZI-3.5].)
3	TP sensor (See THROTTLE POSITION (TP) SENSOR INSPECTION [MZI-3.5].)
4	CHT sensor (See CYLINDER HEAD TEMPERATURE (CHT) SENSOR REMOVAL/INSTALLATION [MZI-3.5].) (See CYLINDER HEAD TEMPERATURE (CHT) SENSOR INSPECTION [MZI-3.5].)
5	CKP sensor (See CRANKSHAFT POSITION (CKP) SENSOR REMOVAL/INSTALLATION [MZI-3.5].) (See CRANKSHAFT POSITION (CKP) SENSOR INSPECTION [MZI-3.5].)
6	CMP sensor (See CAMSHAFT POSITION (CMP) SENSOR REMOVAL/INSTALLATION [MZI-3.5].) (See CAMSHAFT POSITION (CMP) SENSOR INSPECTION [MZI-3.5].)

7	KS (See KNOCK SENSOR (KS) REMOVAL/INSTALLATION [MZI-3.5].) (See KNOCK SENSOR (KS) INSPECTION [MZI-3.5].)
8	Front HO2S (See FRONT HEATED OXYGEN SENSOR (HO2S) REMOVAL/INSTALLATION [MZI-3.5].) (See FRONT HEATED OXYGEN SENSOR (HO2S) INSPECTION [MZI-3.5].)
9	Rear HO2S (See REAR HEATED OXYGEN SENSOR (HO2S) REMOVAL/INSTALLATION [MZI-3.5].) (See REAR HEATED OXYGEN SENSOR (HO2S) INSPECTION [MZI-3.5].)
10	PSP switch (See POWER STEERING PRESSURE (PSP) SWITCH INSPECTION [MZI-3.5].)
11	APP sensor (See ACCELERATOR PEDAL POSITION (APP) SENSOR INSPECTION [MZI-3.5].)
12	Fuel tank pressure sensor (See FUEL TANK PRESSURE SENSOR INSPECTION [MZI-3.5].)

**Fig. 1: Identifying Control System Components**  
Courtesy of MAZDA MOTORS CORP.

## CONTROL SYSTEM DIAGRAM [MZI-3.5]

## 2007 Mazda CX-9 Grand Touring

2007 ENGINE PERFORMANCE Control System (MZI-3.5) - CX-9

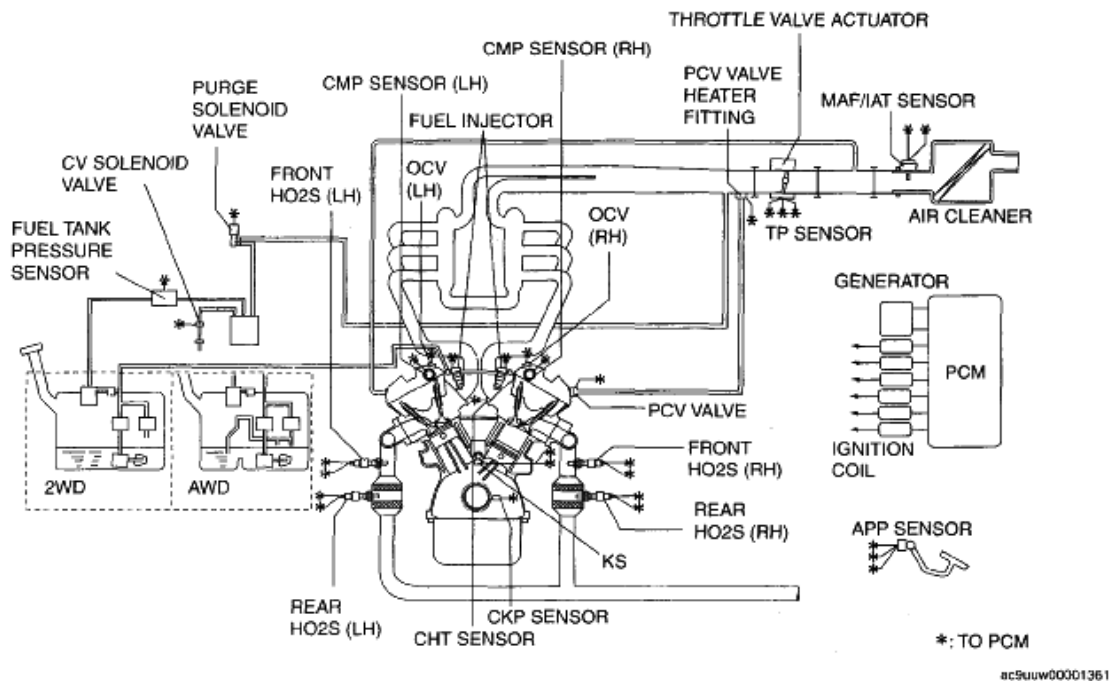

**Fig. 2: Control System Diagram**

Courtesy of MAZDA MOTORS CORP.

## PCM REMOVAL/INSTALLATION [MZI-3.5]

### NOTE:

- For replace the PCM, Setup the M-MDS and perform the PCM configuration. (See PCM CONFIGURATION [MZI-3.5].)

1. Disconnect the negative battery cable.
2. Remove the battery and battery tray. (see BATTERY REMOVAL/INSTALLATION [MZI-3.5].)

### NOTE:

- Only 2 PCM connectors.

3. Disconnect connectors.
4. Remove PCM and bracket as and assembly.
5. Remove PCM from bracket.
6. When replacing the PCM on the vehicles, perform the following.
  - PCM parameter reset. (see IMMOBILIZER SYSTEM COMPONENT REPLACEMENT/KEY ADDITION AND CLEARING [ADVANCED KEYLESS SYSTEM].) (See IMMOBILIZER SYSTEM COMPONENT REPLACEMENT/KEY ADDITION AND CLEARING [KEYLESS ENTRY SYSTEM].)
7. Install in the reverse order of removal.

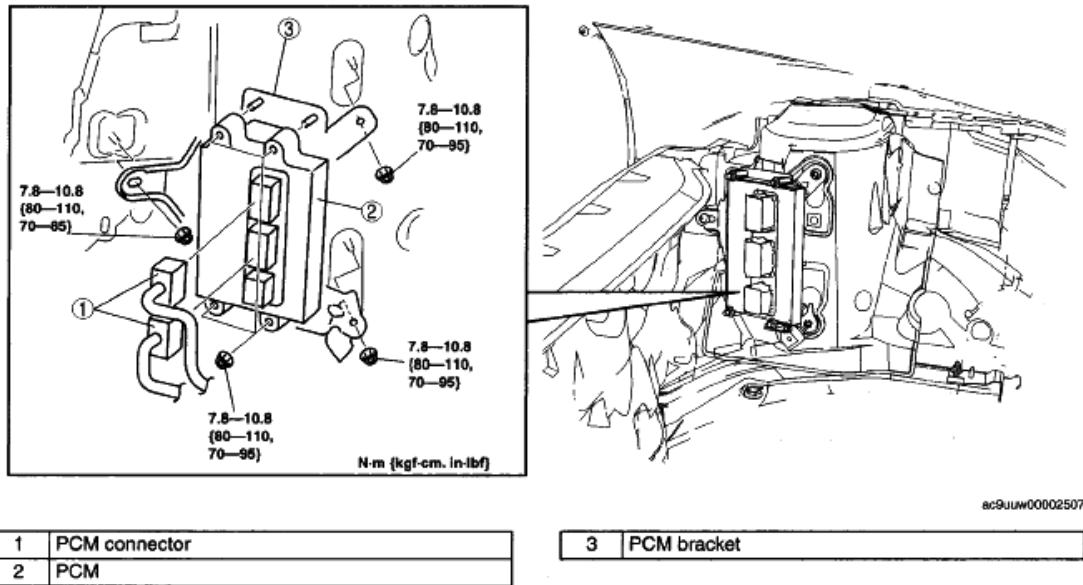

**Fig. 3: Identifying PCM Components With Torque Specifications**  
 Courtesy of MAZDA MOTORS CORP.

## PCM INSPECTION [MZI-3.5]

**CAUTION:**

- The PCM terminal voltage can vary with the conditions when measuring and changes due to aged deterioration on the vehicle, causing false diagnosis. Therefore determine comprehensively where the malfunction occurs among the input systems, output systems, and the PCM.

### PCM INSPECTION PREPARATION

1. Disconnect the negative battery cable.
2. Remove the battery and battery tray. (see **BATTERY REMOVAL/INSTALLATION [MZI-3.5]** .)
3. Remove the windshield wiper arm and blade. (see **WINDSHIELD WIPER ARM AND BLADE REMOVAL/INSTALLATION** .)
4. Remove the cowl grille. (see **COWL GRILLE REMOVAL/INSTALLATION** .)
5. Remove the windshield wiper motor. (see **WINDSHIELD WASHER MOTOR REMOVAL/INSTALLATION** .)
6. Remove the cowl panel. (see **COWL PANEL REMOVAL/INSTALLATION** .)
7. Remove the PCM connector still connected.
8. Install the battery and battery tray. (see **BATTERY REMOVAL/INSTALLATION [MZI-3.5]** .)
9. Connect the negative battery cable.

### TYPICAL DIAGNOSTIC REFERENCE VALUES

## 2007 Mazda CX-9 Grand Touring

2007 ENGINE PERFORMANCE Control System (MZI-3.5) - CX-9

### PCM WIRING HARNESS-SIDE CONNECTOR

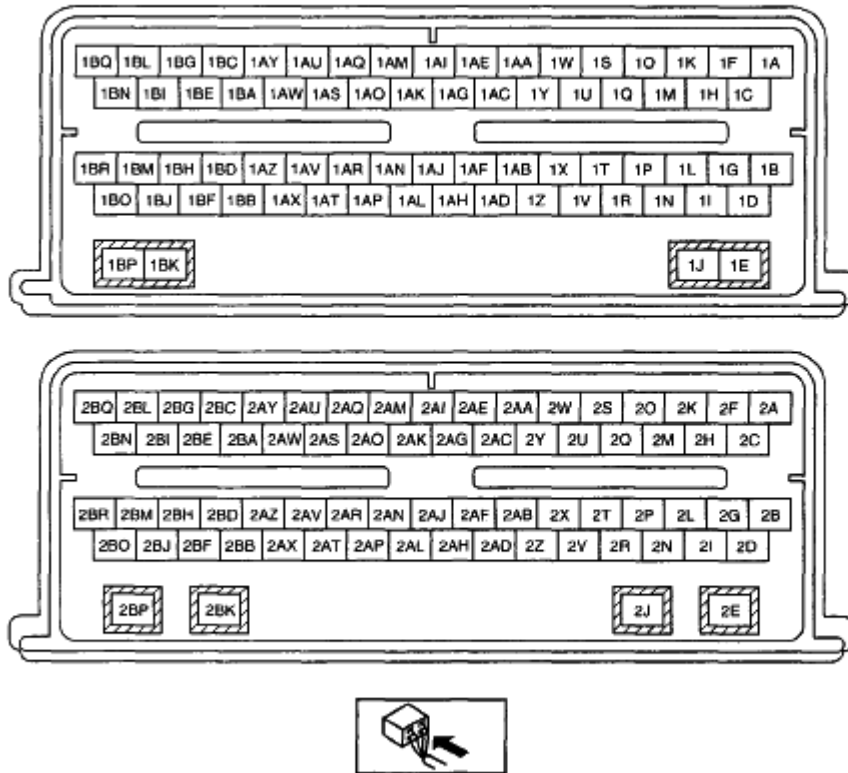

ac9uuw00002429

**Fig. 4: Identifying PCM Connector Terminals**  
Courtesy of MAZDA MOTORS CORP.

### PCM CONNECTOR TERMINALS REFERENCE

Sensors/Inputs	Measured/PID Values				Units Measured/PID
	KOEO	Hot Idle	48 KM/H (30MPH)	89 KM/H (55MPH)	
PSP	0.1/LOW	VBAT/HIGH (I)	0.1/LOW	0.1/LOW	DCV/HIGH-LOW
GENMN (GFS)	11.89/0	VBAT/50	VBAT/28	VBAT/25	DCV/%
APP1	3.9	3.9	3.5	3.3	DCV
APP2	1.6	1.7	1.8	2.1	DCV
APP3	1.0	1.0	1.3	1.5	DCV
FPM	OFF	ON	ON	ON	ON-OFF
ACP	0.8/70	0.86/73	0.9/75	1.0/87	DCV/psi
MAF	0	0.7	1.4	1.5	DCV
MAF SIGRTN	0	0.6-1.9	1-1.6	1.3-2.3	DCV
IAT	80 (K)	50 (K)	37 (K)	34 (K)	DEG F

## 2007 Mazda CX-9 Grand Touring

2007 ENGINE PERFORMANCE Control System (MZI-3.5) - CX-9

FTP	2.6/-0.01	2.6/-0.01	2.6/-0.01	2.6/-0.01	DCV/psi
BOO	VBAT/OFF	0.1/ON (E)	VBAT/OFF	VBAT/OFF	DCV/ON-OFF
BPA	0.1/OFF	VBAT/ON (E)	0.1/OFF	0.1/OFF	DCV/ON-OFF
FEPS	0.5-0.6	0.5-0.6	0.5-0.6	0.5-0.6	DCV
sees	5	0.1 (P)	5	5	DCV
HO2S12	(L)	(D)	(D)	(D)	DCV
HO2S22	0.1	(D)	(D)	(D)	DCV
HO2S21	0	switching (C)	switching (C)	switching (C)	DCV
HO2S11	(L)	switching (C)	switching (C)	switching (C)	DCV
CHT	3.6/199	3.6/199	3.58/201	3.45/208	DCV/DEG F
CMP2	0	5-7	13-16	20-23	Hz
CMP1	0	5-7	13-16	20-23	Hz
CKP	0	400-500	850-1050	1050-1150	Hz
KNOCK 1	23.99k	25.01k	25.73k	44.51k	N/A
TP2	1.1/25	0.8/15	1.0/19	1.4/27	DCV/%
TP1	4.1/17	4.4/13	4.2/16	4.0/19	DCV/%
ACCS	VBAT/OFF	VBAT/ON (A)	VBAT/OFF	VBAT/OFF	DCV/ON-OFF
APP	3.9	0	0	22	%
APP_FLT	NO FAULT	NO FAULT	NO FAULT	NO FAULT	FAULT-NO FAULT
CPP/PNP	NEUTRAL	NEUTRAL	DRIVE	DRIVE	NEUTRAL-DRIVE
ETC_ACT	7.56	1.27	6.22	12.74	DEG
ETC_DSD	7.62	1.31	6.19	12.73	DEG
ETC_TRIM	0.23	0.21	0.24	0.24	DEG
FANVAR	NO FAULT	NO FAULT	NO FAULT	NO FAULT	FAULT- NO FAULT
FLI	71 (H)	72 (H)	82 (H)	81 (H)	%
LOAD	51.4 (L)	16.1	35.4	34.7	%
MISFIRE	NO	NO	NO	NO	YES-NO
RPM	0	600	1200	1500	RPM
VSS	0	0	30	55	MPH
WAC F	NO FAULT	NO FAULT	NO FAULT	NO FAULT	FAULT- NO FAULT

### PCM CONNECTOR TERMINALS REFERENCE

Actuators/Outputs	Measured/PID Values				Units Measured/PID
	KOEO	Hot Idle	48 KM/H (30MPH)	89 KM/H (55MPH)	
GENFDC	3.79	0	0	0	%
SMC	0	0	0	0	DCV
CTO	0	0	0	0	Hz

## 2007 Mazda CX-9 Grand Touring

2007 ENGINE PERFORMANCE Control System (MZI-3.5) - CX-9

EVMV	0	337	0	847	mA
EVAPCV	0	0	0	0	%
FP	8.3/75	3.6/27	3.6/27	3.8/29	DCV/%
WAC/ACCR	OFF	OFF	OFF	OFF	ON-OFF
HTR12	VBAT/OFF	0.2/ON	0.2/ON	0.2/ON	DCV/ON-OFF
HTR22	VBAT/OFF	0.2/ON	0.2/ON	0.2/ON	DCV/ON-OFF
CD6F (CYL 6)	VBAT	VBAT	VBAT	VBAT	DCV
CD5D (CYL 5)	VBAT	VBAT	VBAT	VBAT	DCV
CD4B (CYL 4)	VBAT	VBAT	VBAT	VBAT	DCV
CD3E (CYL 3)	VBAT	VBAT	VBAT	VBAT	DCV
CD2C (CYL 2)	VBAT	VBAT	VBAT	VBAT	DCV
CD1A (CYL 1)	VBAT	VBAT	VBAT	VBAT	DCV
PCVHC	0	0	0	0	%
TACM (+)	3.7	VBAT	VBAT	VBAT	DCV
INJ2	0	2.6-3.2	2.5-5.5	3.5-8.5	mS
INJ4	0	2.6-3.2	2.5-5.5	3.5-8.5	mS
INJ6	0	2.6-3.2	2.5-5.5	3.5-8.5	mS
TACM (-)	3.7	VBAT	VBAT	VBAT	DCV
INJ1	0	2.6-3.2	2.5-5.5	3.5-8.5	mS
INJ3	0	2.6-3.2	2.5-5.5	3.5-8.5	mS
INJ5	0	2.6-3.2	2.5-5.5	3.5-8.5	mS
VCTADV	0	-0.31	-27.56	-30.94	DEG
VCTADV2	0	0	-27.69	-31.06	DEG
HTR11	0.1/ON (O)	0.1/ON	0.1/ON	0.1/ON	DCV/ON-OFF
HTR21	0.1/ON (0)	0.1/ON	0.1/ON	0.1/ON	DCV/ON-OFF
FANVAR	0	0	0	0	%
FANDC	7.5	7.5	7.5	7.5	%
FP	ON/OFF	ON	ON	ON	ON-OFF
LONGFT1	(L)	(-)20-(+)20	(-)20-(+)20	(-)20-(+)20	%
LONGFT2	(L)	(-)20-(+)20	(-)20-(+)20	(-)20-(+)20	%
MIL	OFF	OFF	OFF	OFF	ON-OFF
SHRTFT1	(D)	(-)10-(+)10	(-)10-(+)10	(-)10-(+)10	%
SHRTFT2	(L)	(-)10-(+)10	(-)10-(+)10	(-)10-(+)10	%
SPARKADV	10	13.25	44	45.25	DEG
VCTDC	0	0	47.32	80	%
VCTDC2	0	0	46.8	80	%
VCTADVERR	0	0.18	-0.37	-0.18	DEG

## 2007 Mazda CX-9 Grand Touring

2007 ENGINE PERFORMANCE Control System (MZI-3.5) - CX-9

VCTADVERR2	0	0.06	-0.43	0	DEG
------------	---	------	-------	---	-----

### PCM CONNECTOR TERMINALS REFERENCE

Other	Measured/PID Values				Units Measured/PID
	KOEO	Hot Idle	48 KM/H (30MPH)	89 KM/H (55MPH)	
ETCVREF	5	5	5	5	DCV
VREF	5	5	5	5	DCV
VPWR	VBAT	VBAT	VBAT	VBAT	DCV
KAPWR	VBAT	VBAT	VBAT	VBAT	DCV

### PCM CONFIGURATION [MZI-3.5]

1. Connect the M-MDS to DLC-2.
2. After the vehicle is identified, select the following items from the initialization screen of the M-MDS.
  - When using the IDS (laptop PC)
    1. Select the "Toolbox" tab.
    2. Select the "Module Programming".
  - When using the PDS (Pocket PC)
    1. Select "Programming".
    2. Select "Module Programming".
3. Then, select the "Programmable Module Installation", "PCM" from the screen menu.
4. Select "PCM" and perform procedures according to directions on the M-MDS screen.
5. Retrieve DTCs by the M-MDS, then verify that there is no DTC present.
  - If a DTC is present, perform the applicable DTC inspection.

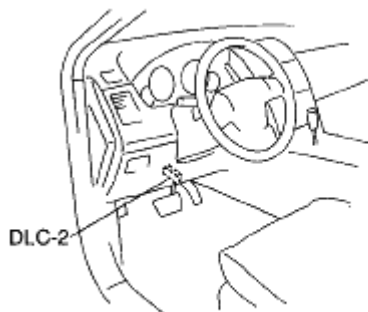

sc9uuw00001090

**Fig. 5: Identifying DLC-2 Connector**  
Courtesy of MAZDA MOTORS CORP.

### POWER STEERING PRESSURE (PSP) SWITCH INSPECTION [MZI-3.5]

#### CONTINUITY INSPECTION



## 2007 Mazda CX-9 Grand Touring

2007 ENGINE PERFORMANCE Control System (MZI-3.5) - CX-9

1. Disconnect the PSP switch connector.
2. Start the engine.
3. Verify no continuity between the PSP switch terminals while rotating the steering wheel.
  - If there is continuity, verify that P/S oil pump is normal and replace the PSP switch. (see **POWER STEERING OIL PUMP DISASSEMBLY/ASSEMBLY** .)
  - If the monitor item condition/specification (reference) is not within the specification, even though there is no malfunction, perform the "Circuit Open/Short Inspection".

### CIRCUIT OPEN/SHORT INSPECTION

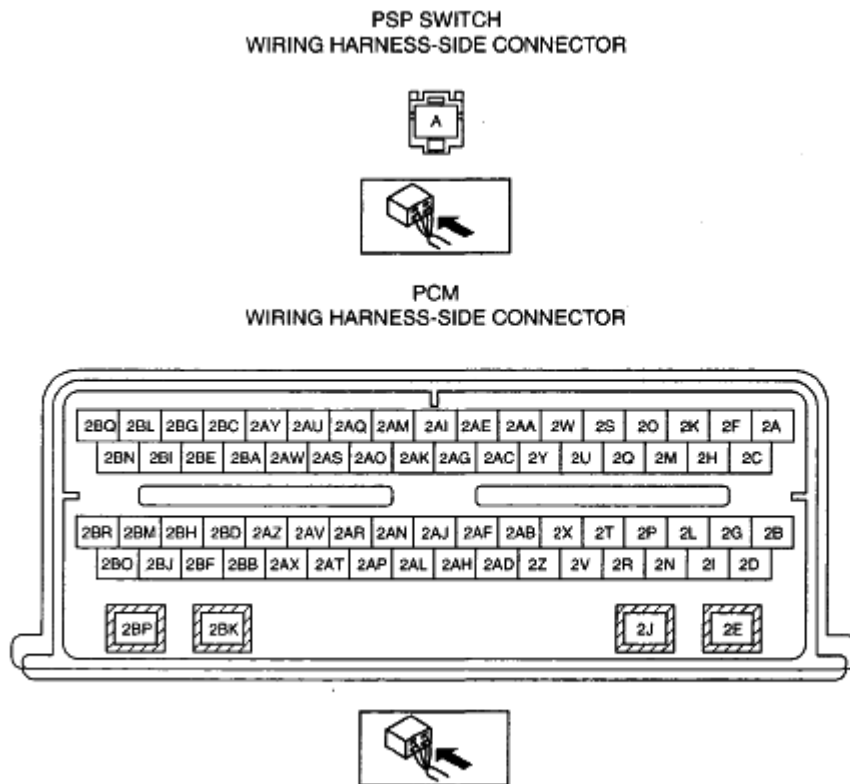

ac9uuw00000939

**Fig. 6: Identifying PSP Switch & PCM Related Connector Terminals**  
Courtesy of MAZDA MOTORS CORP.

1. Disconnect the PCM connector. (See **PCM REMOVAL/INSTALLATION [MZI-3.5]**.)
2. Inspect the following wiring harness for open or short. (Continuity inspection)

#### Open circuit

- If there is no continuity, the circuit is open. Repair or replace the wiring harness.
  - PSP switch terminal A and PCM terminal 21

#### Short circuit

- If there is continuity, the circuit is shorted. Repair or replace the wiring harness.
  - PSP switch terminal A and body ground

## MASS AIR FLOW (MAF)/INTAKE AIR TEMPERATURE (IAT) SENSOR REMOVAL/INSTALLATION [MZI-3.5]

1. Disconnect the negative battery cable.
2. Disconnect MAF/IAT sensor connector.
3. Remove the MAF/IAT sensor.
4. Install in the reverse order of removal.

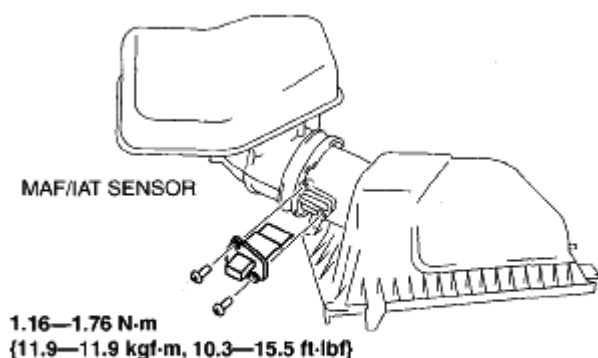

ac9uaw0000430

**Fig. 7: Identifying MAF/IAT Sensor With Torque Specifications**  
Courtesy of MAZDA MOTORS CORP.

## MASS AIR FLOW (MAF) SENSOR INSPECTION [MZI-3.5]

### NOTE:

- Before performing the following inspection, make sure to follow the procedure as indicated in the troubleshooting flowchart. (see HOW TO USE THIS MANUAL .)

### VISUAL INSPECTION

1. Verify the following items of the MAF sensor.
  - Damage, cracks
  - Rusted sensor terminal
  - Bent sensor terminal
    - If there is any malfunction, replace the MAF sensor. (See MASS AIR FLOW (MAF)/INTAKE AIR TEMPERATURE (IAT) SENSOR REMOVAL/INSTALLATION [MZI-3.5].)

## VOLTAGE INSPECTION

1. Remove the MAF sensor with the connector still connected.
2. Turn the ignition switch to the ON position.
3. Verify that the MAF sensor output voltage (M-MDS monitor item: MAF) changes when wind is introduced gradually to the sensor part of the MAF sensor.
  - If it cannot be verified even though the related harnesses have no malfunction, replace the MAF sensor. (See **MASS AIR FLOW (MAF)/INTAKE AIR TEMPERATURE (IAT) SENSOR REMOVAL/INSTALLATION [MZI-3.5].**)
  - If the monitor item status/specification (reference) is not within the specification, even though the resistance is within the specification, perform the "Circuit Open/Short Inspection".

## CIRCUIT OPEN/SHORT INSPECTION

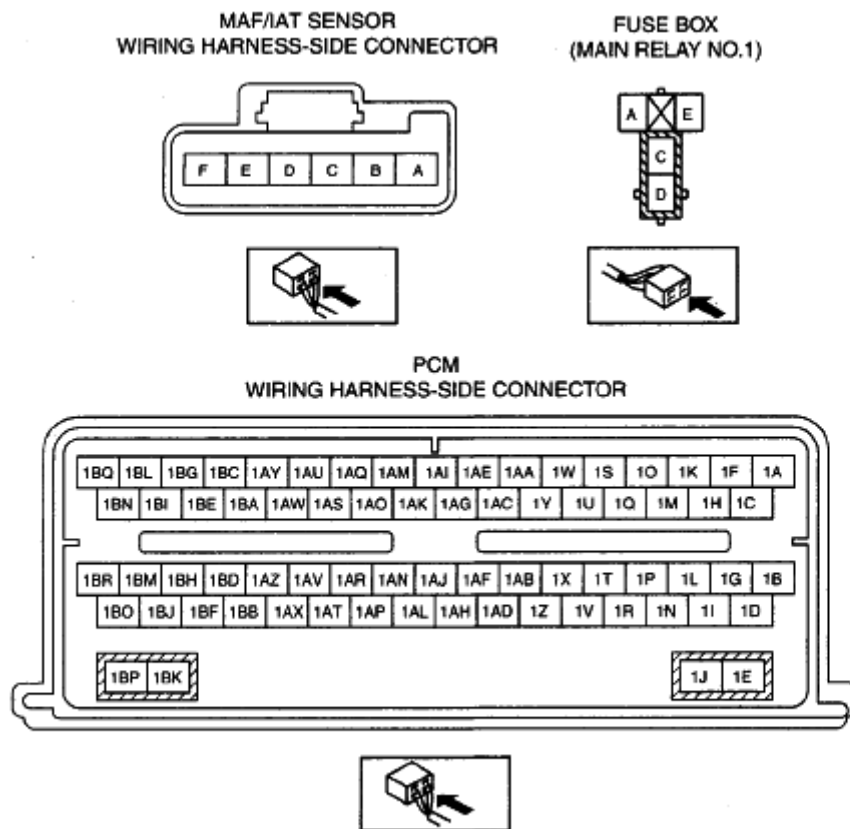

ac9uuw0000940

**Fig. 8: Identifying MAF/IAT Sensor & PCM Related Connector Terminals**  
 Courtesy of MAZDA MOTORS CORP.

1. Disconnect the PCM connector. (See **PCM REMOVAL/INSTALLATION [MZI-3.5].**)
2. Disconnect the MAF/IAT sensor connector.
3. Inspect the following wiring harnesses for open or short. (Continuity inspection)

## 2007 Mazda CX-9 Grand Touring

2007 ENGINE PERFORMANCE Control System (MZI-3.5) - CX-9

### Open circuit

- If there is no continuity, the circuit is open. Repair or replace the wiring harness.
  - MAF/IAT sensor terminal A and main relay No.1 terminal D
  - MAF/IAT sensor terminal C and PCM terminal 1AJ
  - MAF/IAT sensor terminal D and PCM terminal 1 AN
  - MAF/IAT sensor terminal E and PCM terminal 1AL

### Short circuit

- If there is continuity, the circuit is shorted. Repair or replace the wiring harness.
  - MAF/IAT sensor terminal A and body ground
  - MAF/IAT sensor terminal C and power supply
  - MAF/IAT sensor terminal C and body ground
  - MAF/IAT sensor terminal D and power supply
  - MAF/IAT sensor terminal D and body ground
  - MAF/IAT sensor terminal E and power supply

## INTAKE AIR TEMPERATURE (IAT) SENSOR INSPECTION [MZI-3.5]

### NOTE:

- Before performing the following inspection, make sure to follow the procedure as indicated in the troubleshooting flowchart. (see HOW TO USE THIS MANUAL .)

### RESISTANCE INSPECTION

1. Disconnect the MAF/IAT sensor connector.
2. Measure the resistance between MAF/IAT sensor terminals A and F.
  - If not within the specification, replace the MAF/IAT sensor. (See MASS AIR FLOW (MAF)/INTAKE AIR TEMPERATURE (IAT) SENSOR REMOVAL/INSTALLATION [MZI-3.5].)
  - If the monitor item status/specification (reference) is not within the specification, even though the resistance is within the specification, perform the "Circuit Open/Short Inspection".

### IAT sensor resistance

#### IAT SENSOR RESISTANCE REFERENCE

IAT (°C {°F})	Resistance (kilohm)
10 {50}	Approx. 58.75
20 {68}	Approx. 37.30
30 {86}	Approx. 24.27
60 {140}	Approx. 7.70

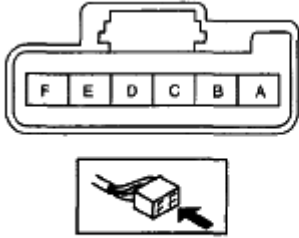

ac9auw00001094

**Fig. 9: Identifying Intake Air Temperature (IAT) Sensor Connector Terminals**  
Courtesy of MAZDA MOTORS CORP.

IAT sensor characteristics graph (reference)

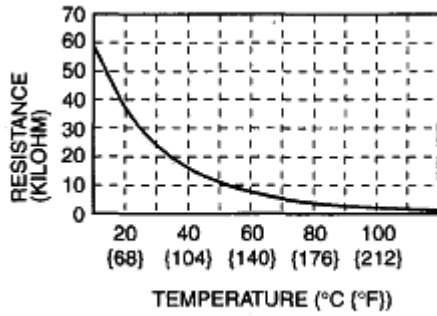

atraaw00000197

**Fig. 10: IAT Sensor Characteristics Graph**  
Courtesy of MAZDA MOTORS CORP.

**CIRCUIT OPEN/SHORT INSPECTION**

MAF/IAT SENSOR  
WIRING HARNESS-SIDE CONNECTOR

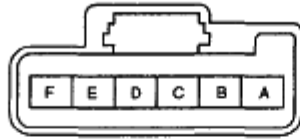

PCM  
WIRING HARNESS-SIDE CONNECTOR

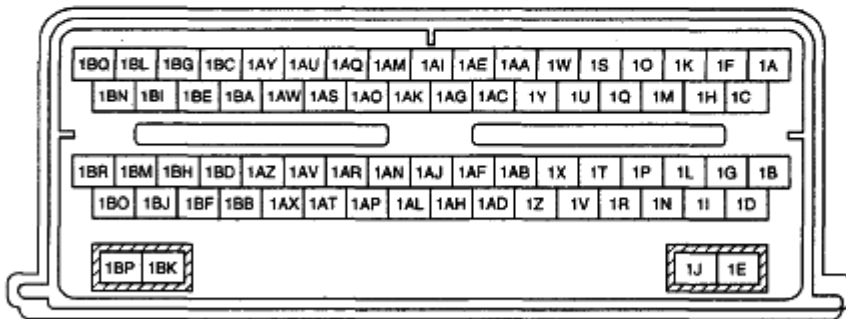

ac9uuw00000951

**Fig. 11: Identifying MAF/IAT Sensor & PCM Related Connector Terminals**  
Courtesy of MAZDA MOTORS CORP.

1. Disconnect the PCM connector. (See **PCM REMOVAL/INSTALLATION [MZI-3.5].**)
2. Inspect the following wiring harnesses for open or short. (Continuity inspection)

**Open circuit**

- If there is no continuity, the circuit is open. Repair or replace the wiring harness.
  - MAF/IAT sensor terminal B and body ground
  - MAF/IAT sensor terminal F and PCM terminal 1AF

**Short circuit**

- If there is continuity, the circuit is shorted. Repair or replace the wiring harness.
  - MAF/IAT sensor terminal B and power supply
  - MAF/IAT sensor terminal F and body ground
  - MAF/IAT sensor terminal F and power supply

**THROTTLE POSITION (TP) SENSOR INSPECTION [MZI-3.5]**

**NOTE:**

- Before performing the following inspection, make sure to follow the procedure as indicated in the troubleshooting flowchart. (see HOW TO USE THIS MANUAL .)

**VOLTAGE INSPECTION**

1. Verify that no DTC related to APP sensor has been detected.
  - If any DTCs related to APP sensor have been detected, perform the DTC inspection. (see DTC TABLE [MZI-3.5] .)
2. Connect the M-MDS to the DLC-2.
3. Turn the ignition switch to the ON position.
4. Select TP1 or TP2 PID (voltage) on the M-MDS.

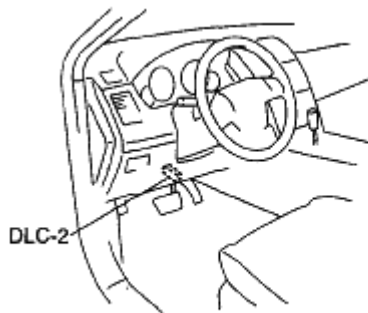

ac9uuw00001450

**Fig. 12: Identifying DLC-2 Connector**  
 Courtesy of MAZDA MOTORS CORP.

5. Operate the accelerator pedal and verify that the TP1 or TP2 PID (voltage) changes as shown in the following graph.
  - If not verified, perform the "Circuit Open/Short Inspection".
    - If there is no open or short circuit, replace the throttle body. (see INTAKE-AIR SYSTEM REMOVAL/INSTALLATION [MZI-3.5] .)

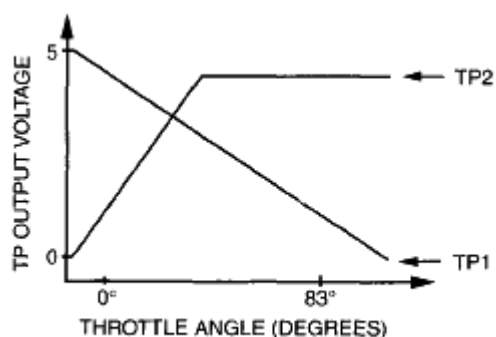

ac9uuw00002506

**Fig. 13: Throttle Output Voltage Graph**

Courtesy of MAZDA MOTORS CORP.

**CIRCUIT OPEN/SHORT INSPECTION**

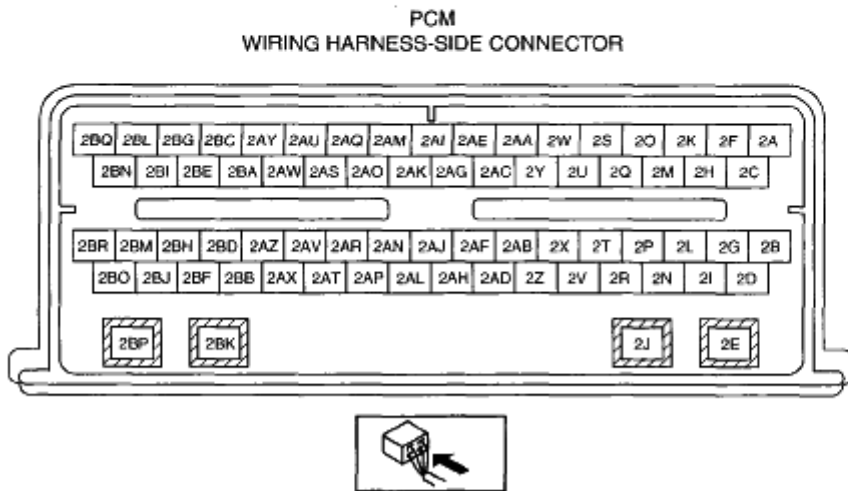
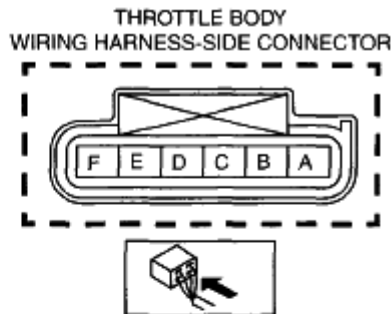

ac9uuw00002653

**Fig. 14: Identifying Throttle Body & PCM Related Connector Terminals**  
Courtesy of MAZDA MOTORS CORP.

1. Disconnect the PCM connector. (See PCM REMOVAL/INSTALLATION [MZI-3.5].)
2. Inspect the following wiring harnesses for open or short circuit. (Continuity inspection)

**Open circuit**

- If there is no continuity, there is an open circuit. Repair or replace the wiring harness.
  - Throttle body terminal C and PCM terminal 2AD
  - Throttle body terminal D and PCM terminal 2D
  - Throttle body terminal E and PCM terminal 2AH
  - Throttle body terminal F and PCM terminal 2Z

**Short circuit**





## 2007 Mazda CX-9 Grand Touring

2007 ENGINE PERFORMANCE Control System (MZI-3.5) - CX-9

- If voltage is not as following table, perform the "Circuit Open/Short Inspection".
  - If there is no open or short circuit, replace accelerator pedal. (see **ACCELERATOR PEDAL REMOVAL/INSTALLATION [MZI-3.5]** .)

### APP sensor output voltage

#### APP SENSOR OUTPUT VOLTAGE REFERENCE

Condition	PCM terminal 1AK (APP sensor No.1)	PCM terminal 1AG (APP sensor No.2)	PCM terminal 1AC (APP sensor No.3)
Accelerator pedal released	Approx. 4.1 V	Approx. 1.5 V	Approx. 0.1 V
Accelerator pedal depressed	Approx. 1.0 V	Approx. 3.9 V	Approx. 3.3 V

#### CIRCUIT OPEN/SHORT INSPECTION

ACCELERATOR PEDAL POSITION SENSOR  
WIRING HARNESS-SIDE CONNECTOR



PCM  
WIRING HARNESS-SIDE CONNECTOR

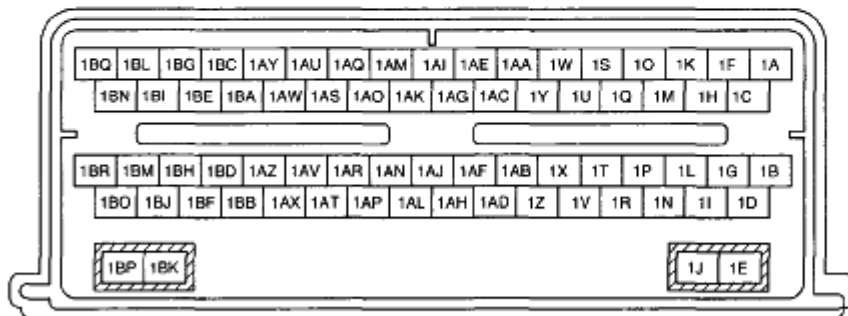

ac9uuw0000982

**Fig. 16: Identifying Accelerator Pedal Position Sensor & PCM Related Connector Terminals**  
Courtesy of MAZDA MOTORS CORP.

1. Disconnect the PCM connector. (See **PCM REMOVAL/INSTALLATION [MZI-3.5]**.)
2. Inspect the following wiring harnesses for open or short circuit. (Continuity inspection)

**Open circuit**

- If there is no continuity, there is an open circuit. Repair or replace the wiring harness.
  - APP sensor terminal B and PCM terminal 1 AC
  - APP sensor terminal C and PCM terminal 1 AH
  - APP sensor terminal D and PCM terminal 1 Y
  - APP sensor terminal E and PCM terminal 1 AK
  - APP sensor terminal F and PCM terminal 1 BA
  - APP sensor terminal G and PCM terminal 1 AD

**Short circuit**

- If there is continuity, there is a short circuit. Repair or replace the wiring harness.
  - APP sensor terminal B and body ground
  - APP sensor terminal B and power supply
  - APP sensor terminal C and power supply
  - APP sensor terminal D and body ground
  - APP sensor terminal E and body ground
  - APP sensor terminal E and power supply
  - APP sensor terminal F and body ground
  - APP sensor terminal G and power supply

**CRANKSHAFT POSITION (CKP) SENSOR REMOVAL/INSTALLATION [MZI-3.5]****NOTE:**

- Disconnect the connector after the CKP sensor is removed to prevent the CKP sensor from falling off.
- The bolt and sensor are integrated and cannot be pulled out.
- When removing the CKP sensor, be careful not to drop the tool.
- The bolt and sensor must be pulled in different directions. Pull them as indicated in the figure.

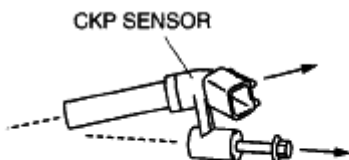

ac3uuw00000460

**Fig. 17: Identifying CKP Sensor**

Courtesy of MAZDA MOTORS CORP.

## REMOVAL

1. Disconnect the negative battery cable.
2. Remove the following part for easier access.
  1. Remove the Catalytic Converter (WU-TWC) (LH).(see **EXHAUST SYSTEM REMOVAL/INSTALLATION [MZI-3.5]** .)
3. Remove in the order indicated in the table.
4. Install in the reverse order of removal.

1	Insulator
2	Cover
3	CKP sensor
4	CKP sensor connector

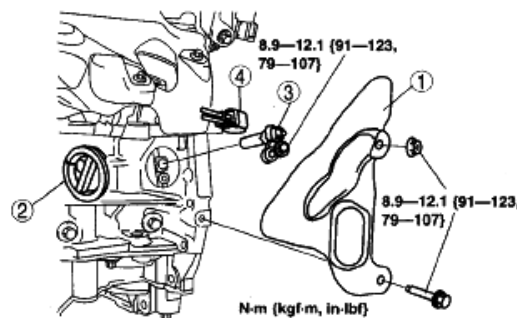

ac9juw0000461

**Fig. 18: Identifying CKP Sensor And Connector With Torque Specifications**  
 Courtesy of MAZDA MOTORS CORP.

## CRANKSHAFT POSITION (CKP) SENSOR INSPECTION [MZI-3.5]

### NOTE:

- Before performing the following inspection, make sure to follow the procedure as indicated in the troubleshooting flowchart. (see **HOW TO USE THIS MANUAL** .)

### VISUAL INSPECTION

1. Remove the CKP sensor. (See **CRANKSHAFT POSITION (CKP) SENSOR REMOVAL/INSTALLATION [MZI-3.5]**.)
2. Verify that there are no metal shavings on the CKP sensor.
3. Install the CKP sensor. (See **CRANKSHAFT POSITION (CKP) SENSOR REMOVAL/INSTALLATION [MZI-3.5]**.)

### RESISTANCE INSPECTION

1. Remove the CKP sensor connector.
2. Measure the resistance between the CKP sensor terminals.

## 2007 Mazda CX-9 Grand Touring

2007 ENGINE PERFORMANCE Control System (MZI-3.5) - CX-9

- If not within the specification, replace the CKP sensor. (See **CRANKSHAFT POSITION (CKP) SENSOR REMOVAL/INSTALLATION [MZI-3.5].**)
- If the monitor item status/specification (reference) is not within the specification, even though the resistance is within the specification, perform the "Circuit Open/Short Inspection".

### CKP sensor resistance

250-1,000 ohms

### CIRCUIT OPEN/SHORT INSPECTION

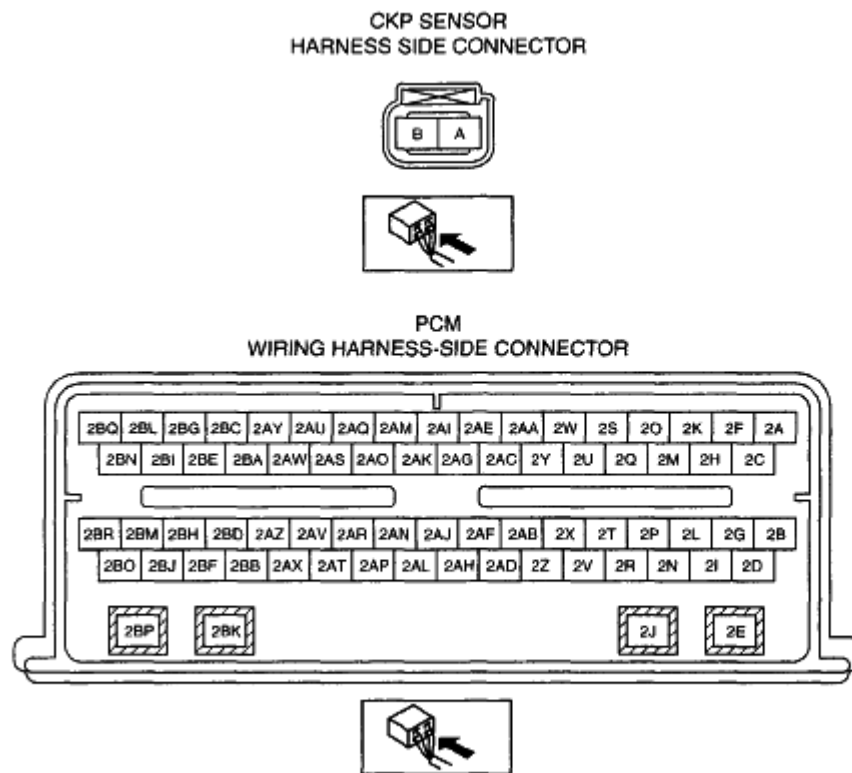

ac9uuw00000985

**Fig. 19: Identifying CKP Sensor & PCM Related Connector Terminals**  
Courtesy of MAZDA MOTORS CORP.

1. Disconnect the PCM connector. (See **PCM REMOVAL/INSTALLATION [MZI-3.5].**)
2. Inspect the following harness for open or short circuit. (Continuity check)

#### Open circuit

- CKP sensor terminal A and PCM terminal 2P
- CKP sensor terminal B and PCM terminal 2T

#### Short circuit

- CKP sensor terminal A and power supply
- CKP sensor terminal A and body ground
- CKP sensor terminal B and power supply
- CKP sensor terminal B and body ground

## CAMSHAFT POSITION (CMP) SENSOR REMOVAL/INSTALLATION [MZI-3.5]

1. Disconnect the negative battery cable.
2. Remove the battery.
3. Remove the following part for easier access.
  - Remove the resonance chamber and air cleaner assy. (see INTAKE-AIR SYSTEM REMOVAL/INSTALLATION [MZI-3.5] .)
4. Disconnect the CMP sensor connector
5. Remove the CMP sensor.

**NOTE:**

- Lubricate the CMP O-ring seal with clean engine oil.

6. Install in the reverse order of removal.

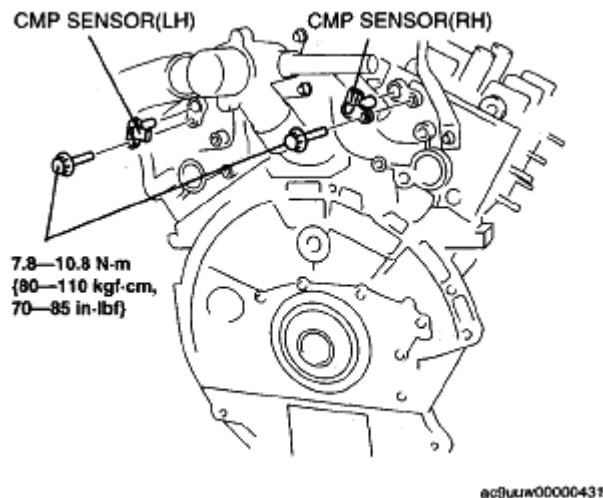

**Fig. 20: View Of CMP Sensor With Torque Specifications**  
Courtesy of MAZDA MOTORS CORP.

## CAMSHAFT POSITION (CMP) SENSOR INSPECTION [MZI-3.5]

**NOTE:**

- Before performing the following inspection, make sure to follow the procedure as indicated in the troubleshooting flowchart. (see HOW TO USE THIS MANUAL .)

## **VISUAL INSPECTION**

1. Remove the CMP sensor. (See **CAMSHAFT POSITION (CMP) SENSOR REMOVAL/INSTALLATION [MZI-3.5].**)
2. Verify that there are no metal shavings on the CMP sensor.
3. Install the CMP sensor. (See **CAMSHAFT POSITION (CMP) SENSOR REMOVAL/INSTALLATION [MZI-3.5].**)

## **RESISTANCE INSPECTION**

1. Remove the CMP sensor connector.
2. Measure the resistance between the CMP sensor terminals.
  - If not within the specification, replace the CMP sensor. (See **CAMSHAFT POSITION (CMP) SENSOR REMOVAL/INSTALLATION [MZI-3.5].**)
  - If the monitor item status/specification (reference) is not within the specification, even though the resistance is within the specification, perform the "Circuit Open/Short Inspection".

### **CMP sensor resistance**

**800-1,320 ohms**

## **CIRCUIT OPEN/SHORT INSPECTION**

## 2007 Mazda CX-9 Grand Touring

2007 ENGINE PERFORMANCE Control System (MZI-3.5) - CX-9

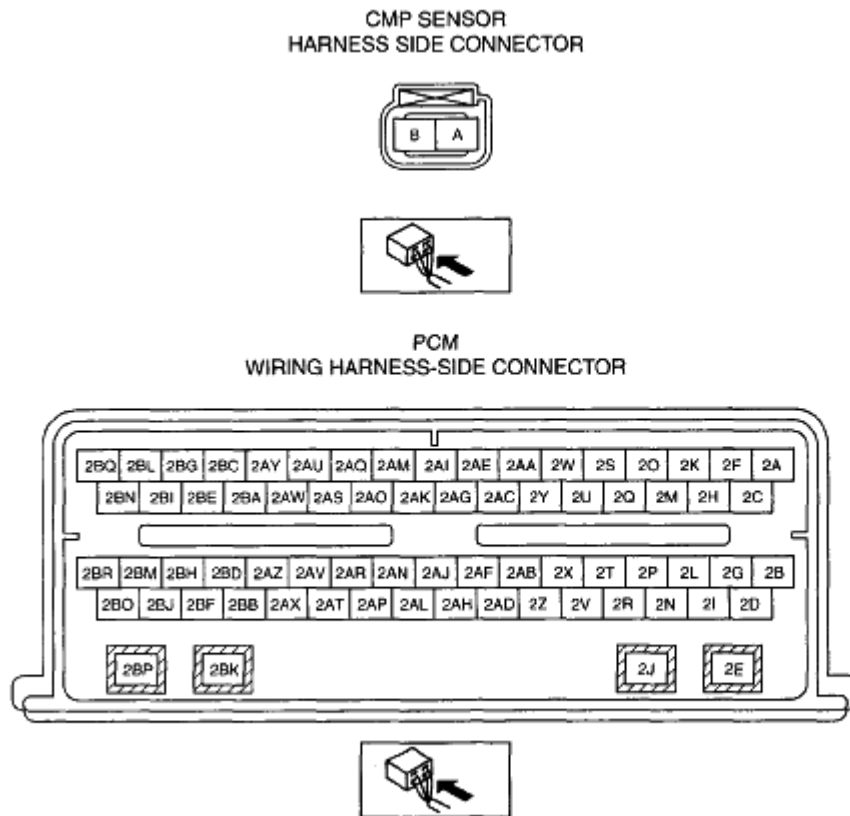

ac9uuw0000987

**Fig. 21: Identifying CMP Sensor & PCM Related Connector Terminals**  
Courtesy of MAZDA MOTORS CORP.

1. Disconnect the PCM connector. (See **PCM REMOVAL/INSTALLATION [MZI-3.5].**)
2. Inspect the following harness for open or short circuit. (Continuity check)

### Open circuit

- CMP sensor (RH) terminal A and PCM terminal 2X
- CMP sensor (RH) terminal B and PCM terminal 2C
- CMP sensor (LH) terminal A and PCM terminal 2AB
- CMP sensor (LH) terminal B and PCM terminal 2C

### Short circuit

- CMP sensor (RH) terminal A and power supply
- CMP sensor (RH) terminal A and body ground
- CMP sensor (RH) terminal B and power supply
- CMP sensor (LH) terminal A and power supply
- CMP sensor (LH) terminal A and body ground



- CMP sensor (LH) terminal B and power supply

## FRONT HEATED OXYGEN SENSOR (HO2S) REMOVAL/INSTALLATION [MZI-3.5]

### HO2S (LH) REMOVAL/INSTALLATION

1. Disconnect the negative battery cable.
2. Remove the engine cover. (see ENGINE COVER REMOVAL/INSTALLATION [MZI-3.5] .)
3. Disconnect the HO2S (LH) connector.

**NOTE:**

- If necessary, lubricate the HO2S with Penetrating and Lock Lubricant loosen to aid in removal.

4. Remove the HO2S (LH) using the SST.

**NOTE:**

- Apply a light coat of anti-seize lubricant to the threads of the HO2S.

5. Install in the reverse order of removal.

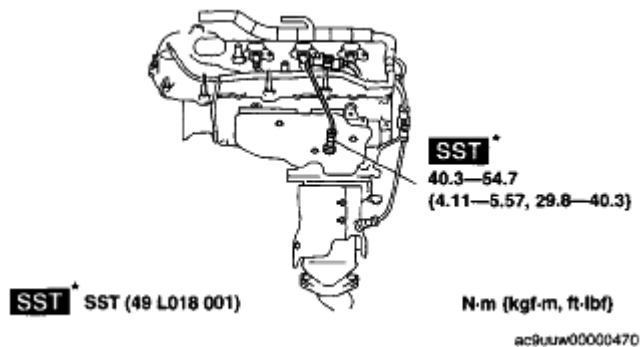

**Fig. 22: View Of LH HO2S With Torque Specifications**  
 Courtesy of MAZDA MOTORS CORP.

### HO2S (RH) REMOVAL/INSTALLATION

1. Disconnect the negative battery cable.
2. Remove the following part for easier access.
  1. Remove the cowl panel. (see COWL PANEL REMOVAL/INSTALLATION .)
3. Disconnect the HO2S (RH) connector.

**NOTE:**

- If necessary, lubricate the HO2S with Penetrating and Lock Lubricant loosen to aid in removal.

- Remove the HO2S (RH) using the SST.

**NOTE:**

- Apply a light coat of anti-seize lubricant to the threads of the HO2S.

- Install in the reverse order of removal.

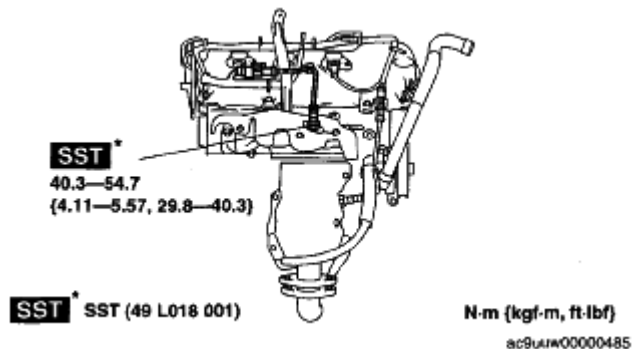

**Fig. 23: View Of RH HO2S With Torque Specifications**  
Courtesy of MAZDA MOTORS CORP.

## FRONT HEATED OXYGEN SENSOR (HO2S) INSPECTION [MZI-3.5]

**NOTE:**

- Before performing the following inspection, make sure to follow the procedure as indicated in the troubleshooting flowchart. (see HOW TO USE THIS MANUAL .)

## FRONT HEATED OXYGEN SENSOR (HO2S) VOLTAGE INSPECTION

- Warm up the engine to normal operating temperature.
- Using the M-MDS, monitor the following:
  - Vehicle speed (PID: VSS)
  - Engine speed (PID: RPM)
  - Front HO2S voltage (PID: O2S11, O2S21)
- Drive the vehicle and decelerate the engine speed by releasing the accelerator pedal fully when the engine speed is **3,000 rpm or more**.
- Verify that the front HO2S outputs a voltage of **0.6 V or more**, one time or more, then verify that the front HO2S voltage (PID: O2S11, O2S21) is **0.3 V or less** while decelerating as shown in the figure.

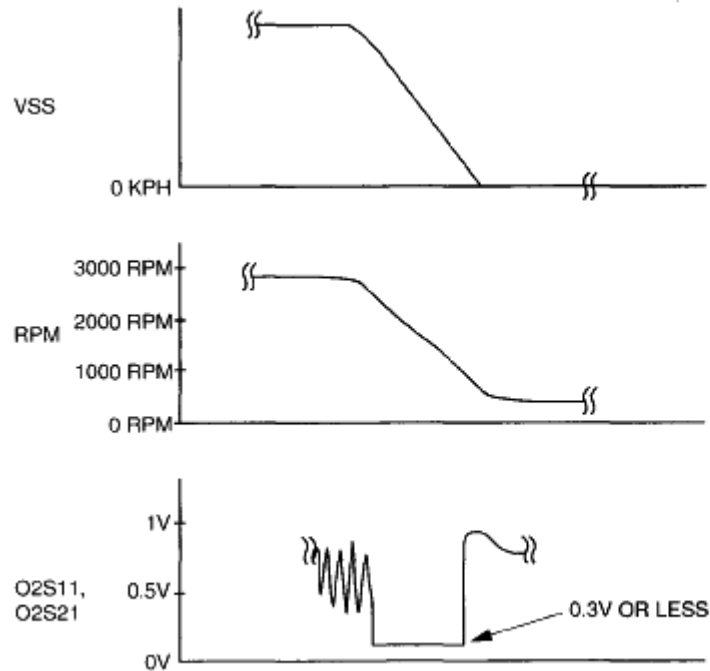

atrbaw00003393

**Fig. 24: Front HO2S Outputs Voltage Graph**  
Courtesy of MAZDA MOTORS CORP.

- If not within the specification, inspect the front HO2S for an open or short circuit. (See **FRONT HEATED OXYGEN SENSOR (HO2S) VOLTAGE INSPECTION**.) Then if there is no malfunction in the wiring harness, replace the front HO2S. (See **FRONT HEATED OXYGEN SENSOR (HO2S) REMOVAL/INSTALLATION [MZI-3.5]**. --> Front Heated Oxygen Sensor (HO2S) Voltage Inspection.) Then if there is no malfunction in the wiring harness, replace the front HO2S. (See **FRONT HEATED OXYGEN SENSOR (HO2S) REMOVAL/INSTALLATION [MZI-3.5]**.)

## HO2S HEATER RESISTANCE INSPECTION

1. Disconnect the HO2S connector.
2. Measure the resistance between HO2S terminals C and A.
  - If it is not within the specification, replace the HO2S. (See **FRONT HEATED OXYGEN SENSOR (HO2S) REMOVAL/INSTALLATION [MZI-3.5]**.)
  - If the monitor item status/specification (reference) is not within the specification, even though the resistance is within the specification, perform the "Circuit Open/Short Inspection".

### HO2S heater resistance

**3-30 ohms**

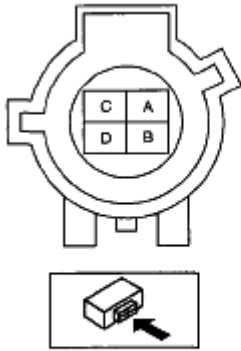

ac9uuw0001096

**Fig. 25: Identifying HO2S Sensor Connector Terminals**  
Courtesy of MAZDA MOTORS CORP.

#### **CIRCUIT OPEN/SHORT INSPECTION**

1. Disconnect the PCM connector. (See **PCM REMOVAL/INSTALLATION [MZI-3.5].**)
2. Inspect the following wiring harness for open or short (continuity check).

## 2007 Mazda CX-9 Grand Touring

2007 ENGINE PERFORMANCE Control System (MZI-3.5) - CX-9

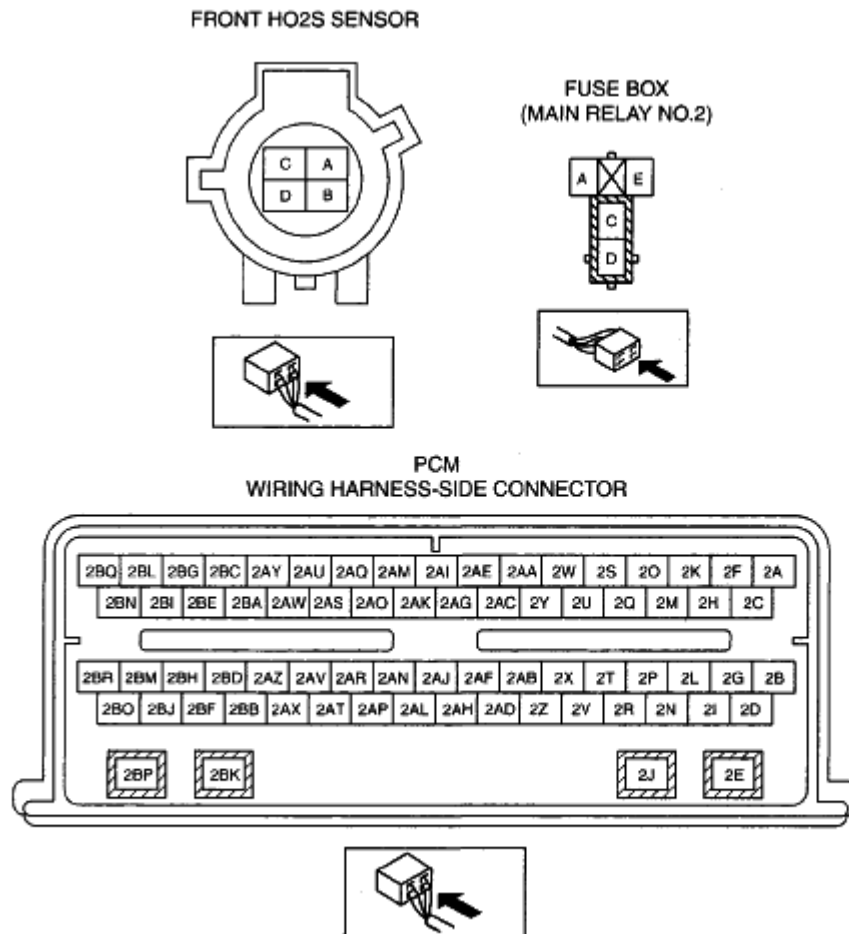

**Fig. 26: Identifying Front HO2S & PCM Related Connector Terminals**  
Courtesy of MAZDA MOTORS CORP.

### Open circuit

- If there is no continuity, the circuit is open. Repair or replace the harness.
  - HO2S (RH) terminal A and PCM terminal 2J
  - HO2S (RH) terminal B and PCM terminal 2Y
  - HO2S (RH) terminal C and main relay No.2 terminal D
  - HO2S (RH) terminal D and PCM terminal 2AL
  - HO2S (LH) terminal A and PCM terminal 2E
  - HO2S (LH) terminal B and PCM terminal 2U
  - HO2S (LH) terminal C and main relay No.2 terminal D
  - HO2S (LH) terminal D and PCM terminal 2AL

### Short circuit

- If there is continuity, the circuit is shorted. Repair or replace the harness.
  - HO2S (RH) terminal A and power supply
  - HO2S (RH) terminal A and body ground
  - HO2S (RH) terminal B and power supply
  - HO2S (RH) terminal B and body ground
  - HO2S (RH) terminal C and body ground
  - HO2S (RH) terminal D and power supply
  - HO2S (LH) terminal A and power supply
  - HO2S (LH) terminal A and body ground
  - HO2S (LH) terminal B and power supply
  - HO2S (LH) terminal B and body ground
  - HO2S (LH) terminal C and body ground
  - HO2S (LH) terminal D and power supply

## REAR HEATED OXYGEN SENSOR (HO2S) REMOVAL/INSTALLATION [MZI-3.5]

### HO2S (LH) REMOVAL/INSTALLATION

1. Disconnect the negative battery cable.
2. Disconnect the HO2S (LH) connector.

**NOTE:**

- If necessary, lubricate the HO2S (LH) with Penetrating and Lock Lubricant loosen to aid in removal.

3. Remove the HO2S (LH) using the SST.

**NOTE:**

- Apply a light coat of anti-seize lubricant to the threads of the HO2S.

4. Install in the reverse order of removal.

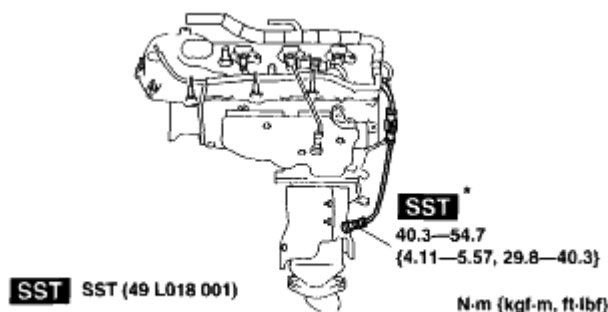

**Fig. 27: View Of LH HO2S With Torque Specifications**  
 Courtesy of MAZDA MOTORS CORP.

### HO2S (RH) REMOVAL/INSTALLATION

1. Disconnect the negative battery cable.
2. Remove the following part for easier access.
  1. Remove the cowl panel. (see COWL PANEL REMOVAL/INSTALLATION .)
3. Disconnect the HO2S (RH) connector.

**NOTE:**

- If necessary, lubricate the HO2S (RH) with Penetrating and Lock Lubricant loosen to aid in removal.

4. Remove the HO2S (RH) using the SST.

**NOTE:**

- Apply a light coat of anti-seize lubricant to the threads of the HO2S.

5. Install in the reverse order of removal.

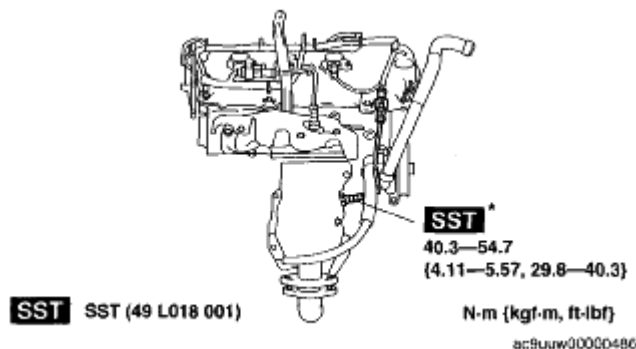

**Fig. 28: View Of RH HO2S With Torque Specifications**  
 Courtesy of MAZDA MOTORS CORP.

### REAR HEATED OXYGEN SENSOR (HO2S) INSPECTION [MZI-3.5]

**NOTE:**

- Before performing the following inspection, make sure to follow the procedure as indicated in the troubleshooting flowchart. (see HOW TO USE THIS MANUAL .)

### REAR HEATED OXYGEN SENSOR (HO2S) VOLTAGE INSPECTION

1. Warm up the engine to normal operating temperature.
2. Using the M-MDS, monitor the following:
  - Vehicle speed (PID: VSS)

- Engine speed (PID: RPM)
  - Rear HO2S voltage (PID: O2S12, O2S22)
3. Drive the vehicle and decelerate the engine speed by releasing the accelerator pedal fully when the engine speed is **3,000 rpm or more**.
  4. Verify that the rear HO2S outputs a voltage of **0.6 V or more**, one time or more, then verify that the rear HO2S voltage (PID: O2S12, O2S22) is **0.3 V or less** while decelerating as shown in the figure.

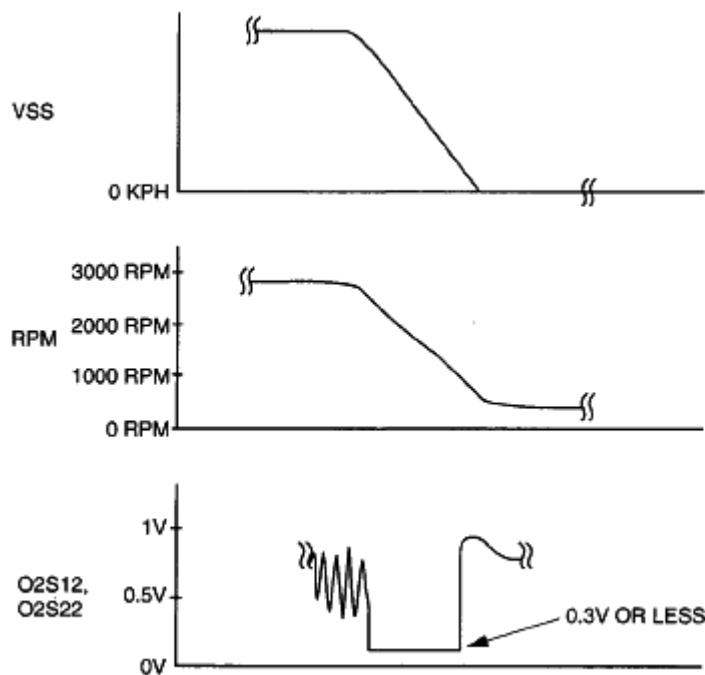

atraaw00003394

**Fig. 29: Rear HO2S Outputs Voltage Graph**  
 Courtesy of MAZDA MOTORS CORP.

- If not within the specification, inspect the rear HO2S for an open or short circuit. Then if there is no malfunction in the wiring harness, replace the rear HO2S. (See **REAR HEATED OXYGEN SENSOR (HO2S) REMOVAL/INSTALLATION [MZI-3.5]**.)

### HO2S HEATER RESISTANCE INSPECTION

1. Disconnect the HO2S connector.
2. Measure the resistance between HO2S terminals C and A.
  - If it is not within the specification, replace the HO2S. (See **REAR HEATED OXYGEN SENSOR (HO2S) REMOVAL/INSTALLATION [MZI-3.5]**.)
  - If the monitor item status/specification (reference) is not within the specification, even though the resistance is within the specification, perform the "Circuit Open/Short Inspection".

### HO2S heater resistance



3-30 ohms

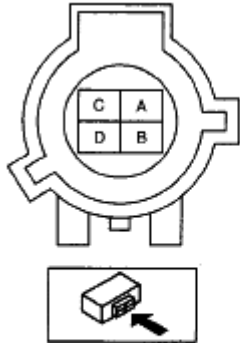

ac9uuw00001097

**Fig. 30: Identifying HO2S & PCM Related Connector Terminals**  
Courtesy of MAZDA MOTORS CORP.

### CIRCUIT OPEN/SHORT INSPECTION

1. Disconnect the PCM connector. (See **PCM REMOVAL/INSTALLATION [MZI-3.5].**)
2. Inspect the following wiring harness for open or short (continuity check).

## 2007 Mazda CX-9 Grand Touring

2007 ENGINE PERFORMANCE Control System (MZI-3.5) - CX-9

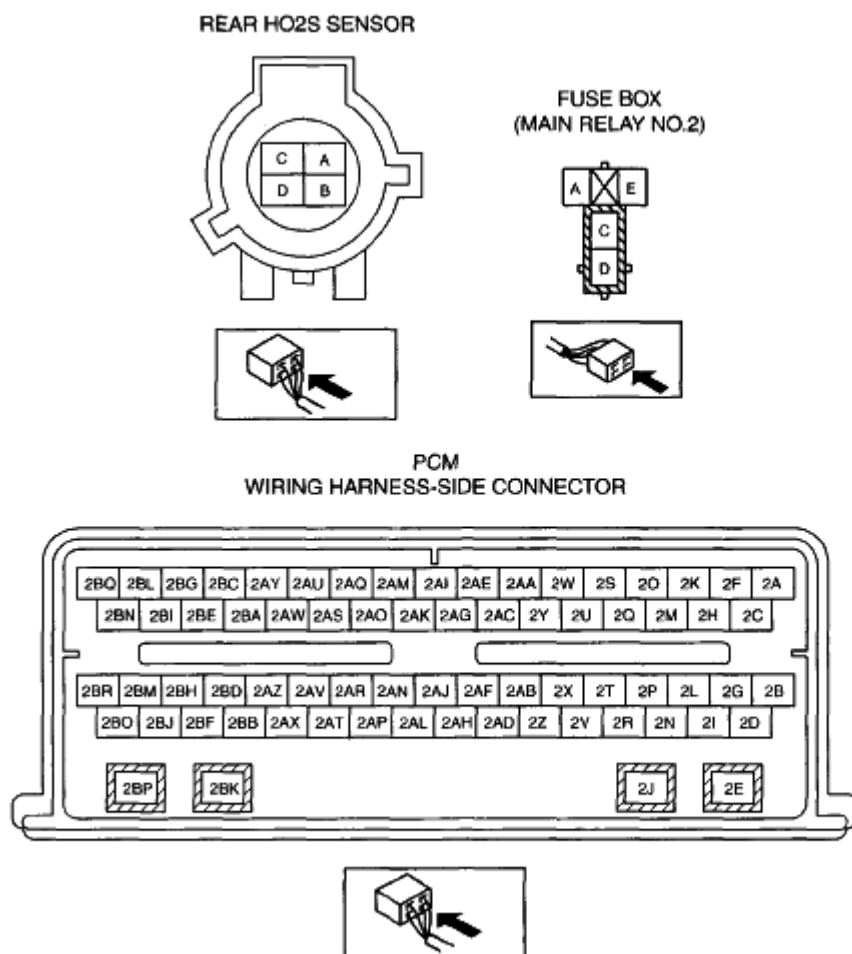

ac9uuw00001002

**Fig. 31: Identifying PCM, HO2S And Main Relay 2 Connector Terminals**  
Courtesy of MAZDA MOTORS CORP.

### Open circuit

- If there is no continuity, the circuit is open. Repair or replace the harness.
  - HO2S (RH) terminal A and PCM terminal 2AS
  - HO2S (RH) terminal B and PCM terminal 2BG
  - HO2S (RH) terminal C and main relay No.2 terminal D
  - HO2S (RH) terminal D and PCM terminal 2AL
  - HO2S (LH) terminal A and PCM terminal 2AO
  - HO2S (LH) terminal B and PCM terminal 2BC
  - HO2S (LH) terminal C and main relay No.2 terminal D
  - HO2S (LH) terminal D and PCM terminal 2AL

### Short circuit

- If there is continuity, the circuit is shorted. Repair or replace the harness.
  - HO2S (RH) terminal A and power supply
  - HO2S (RH) terminal A and body ground
  - HO2S (RH) terminal B and power supply
  - HO2S (RH) terminal B and body ground
  - HO2S (RH) terminal C and body ground
  - HO2S (RH) terminal D and power supply
  - HO2S (LH) terminal A and power supply
  - HO2S (LH) terminal A and body ground
  - HO2S (LH) terminal B and power supply
  - HO2S (LH) terminal B and body ground
  - HO2S (LH) terminal C and body ground
  - HO2S (LH) terminal D and power supply

## **KNOCK SENSOR (KS) REMOVAL/INSTALLATION [MZI-3.5]**

**NOTE:** ● Put a tray under the converter housing to receive the engine coolant.

1. Disconnect the negative battery cable.
2. Remove the following part for easier access. Perform the following procedure to remove the intake manifold
  1. Remove the ventilation hose. (see **QUICK RELEASE CONNECTOR (EMISSION SYSTEM) REMOVAL/INSTALLATION [MZI-3.5].** )
  2. Remove the vacuum hose (to purge solenoid valve). (see **QUICK RELEASE CONNECTOR (EMISSION SYSTEM) REMOVAL/INSTALLATION [MZI-3.5].** )
  3. Remove the fuel hose. (see **QUICK RELEASE CONNECTOR (FUEL SYSTEM) REMOVAL/INSTALLATION [MZI-3.5].** )
  4. Remove the fuel distributor. (see **FUEL INJECTOR REMOVAL/INSTALLATION [MZI-3.5].** )
  5. Remove the intake manifold. (see **INTAKE-AIR SYSTEM REMOVAL/INSTALLATION [MZI-3.5].** )
3. Remove in the order indicated in the table.

**NOTE:** ● Lubricate the new O-ring with clean engine coolant for installation.

4. Install in the reverse order of removal.

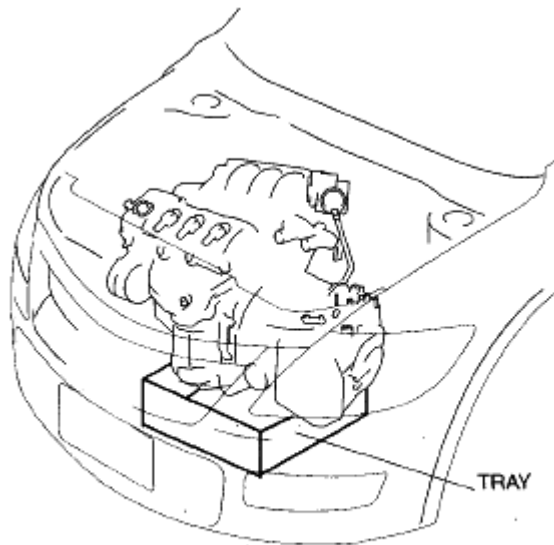

ac9uuw0000464

**Fig. 32: Identifying Tray Under Converter Housing**  
 Courtesy of MAZDA MOTORS CORP.

1	Water inlet pipe
2	O-ring
3	KS connector
4	KS

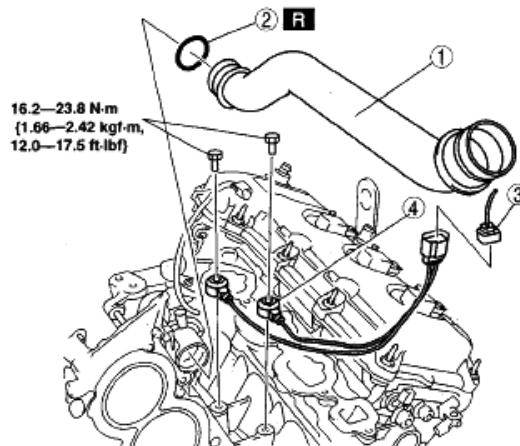

ac9uuw0000485

**Fig. 33: Identifying Water Inlet Pipe And KS Connector With Torque Specifications**  
 Courtesy of MAZDA MOTORS CORP.

## KNOCK SENSOR (KS) INSPECTION [MZI-3.5]

**NOTE:**

- Before performing the following inspection, make sure to follow the procedure as indicated in the troubleshooting flowchart. (see HOW TO USE THIS MANUAL .)

**RESISTANCE INSPECTION**

1. Turn the ignition switch to LOCK.
2. Disconnect the KS connector.
3. Measure the resistance between the KS terminals.

KS(RH): KS terminals A and B

KS(LH): KS terminals C and D

- If not as specified, replace the KS.
- If the KS is normal, but PID value is out of specification, perform the "Circuit Open/Short Inspection".

**KS resistance**

**4.39-5.35 Mohms**

**CIRCUIT OPEN/SHORT INSPECTION**

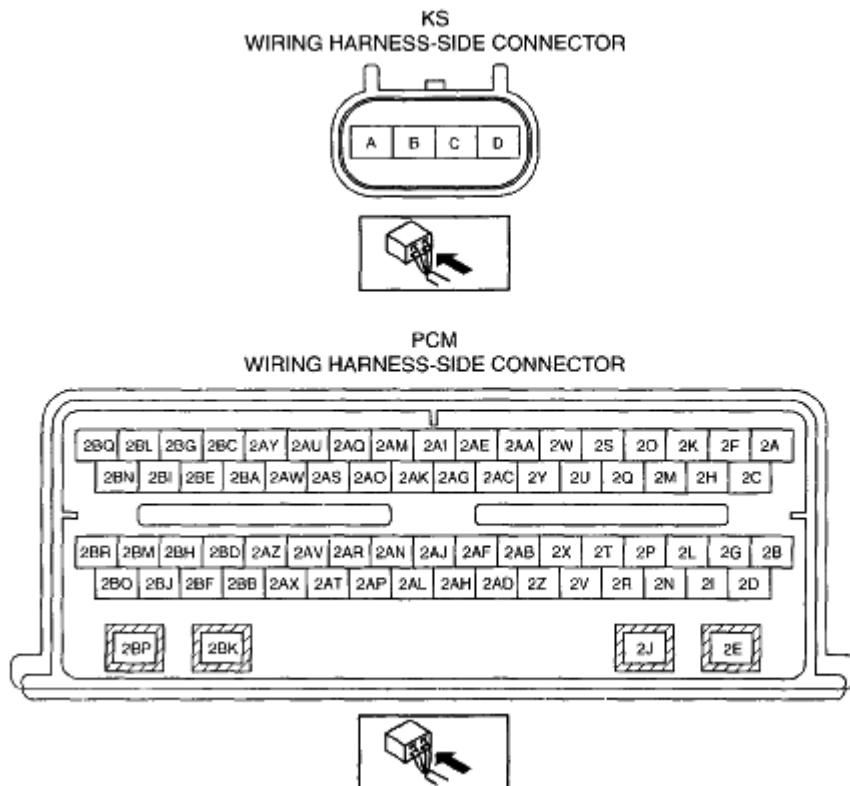

ac8u.w0000983

**Fig. 34: Identifying KS Sensor & PCM Related Connector Terminals**  
 Courtesy of MAZDA MOTORS CORP.

1. Disconnect the PCM connector. (See **PCM REMOVAL/INSTALLATION [MZI-3.5].**)
2. Inspect the following wiring harnesses for open or short. (Continuity inspection)

**Open circuit**

- If there is no continuity, the circuit is open. Repair or replace the wiring harness.
  - KS terminal A and PCM terminal 2Q
  - KS terminal B and PCM terminal 2M
  - KS terminal C and PCM terminal 2L
  - KS terminal D and PCM terminal 2G

**Short circuit**

- If there is continuity, the circuit is shorted. Repair or replace the wiring harness.
  - KS terminal A and power supply
  - KS terminal A and body ground
  - KS terminal B and power supply
  - KS terminal B and body ground
  - KS terminal C and power supply
  - KS terminal C and body ground
  - KS terminal D and power supply
  - KS terminal D and body ground

**CYLINDER HEAD TEMPERATURE (CHT) SENSOR  
REMOVAL/INSTALLATION [MZI-3.5]**

**NOTE:**           • **Do not reuse the CHT sensor, install a new sensor.**

1. Disconnect the negative battery cable.
2. Remove the following part for easier access.

Perform the following procedure to remove the intake manifold.

1. Remove the ventilation hose. (see **QUICK RELEASE CONNECTOR (EMISSION SYSTEM) REMOVAL/INSTALLATION [MZI-3.5].** )
2. Remove the vacuum hose (to purge solenoid valve). (see **QUICK RELEASE CONNECTOR (EMISSION SYSTEM) REMOVAL/INSTALLATION [MZI-3.5].** )
3. Remove the fuel hose. (see **QUICK RELEASE CONNECTOR (FUEL SYSTEM) REMOVAL/INSTALLATION [MZI-3.5].** )
4. Remove the fuel distributor. (see **FUEL INJECTOR REMOVAL/INSTALLATION [MZI-3.5].** )

3. Remove the intake manifold. (see **INTAKE-AIR SYSTEM REMOVAL/INSTALLATION [MZI-3.5]** .)
4. Disconnect the CHT sensor connector.
5. Remove the CHT sensor using the following tools.
  - Socket
    - 3/8", 20mm, 6point
  - Ratchet handle and torque wrench
    - 3/8" Drive

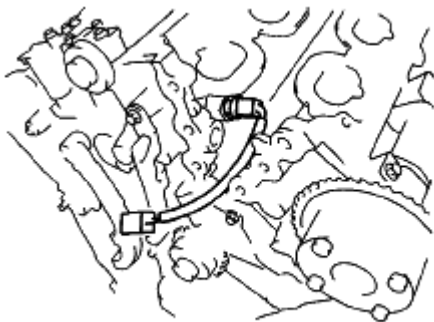

ac9uuw0000466

**Fig. 35: Identifying CHT Sensor Connector**  
Courtesy of MAZDA MOTORS CORP.

6. Install in the reverse order of removal.

**Tightening torque**

**10 N.m {102 kgf.cm, 89 in.lbf}**

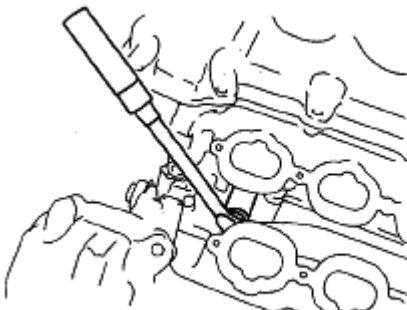

ac9uuw0000467

**Fig. 36: Installing CHT Sensor**  
Courtesy of MAZDA MOTORS CORP.

## CYLINDER HEAD TEMPERATURE (CHT) SENSOR INSPECTION [MZI-3.5]

**NOTE:**

- Before performing the following inspection, make sure to follow the procedure as indicated in the troubleshooting flowchart. (see HOW TO USE THIS MANUAL .)

### RESISTANCE INSPECTION

1. Disconnect the CHT sensor connector.
2. Measure the resistance between the CHT sensor terminals.
  - If it is not within the specification, replace the CHT sensor.
  - If the monitor item status/specification (reference) is not within the specification, even though the resistance is within the specification, perform the "Circuit Open/Short Inspection".

Measure the cylinder head temperature sensor resistance (approx.).

### CYLINDER HEAD TEMPERATURE SENSOR RESISTANCE REFERENCE

Cylinder head temperature (°C {°F})	Resistance (kilohm)
20 {68}	37.387
80 {176}	3.775

Cylinder head temperature sensor characteristics graph (reference)

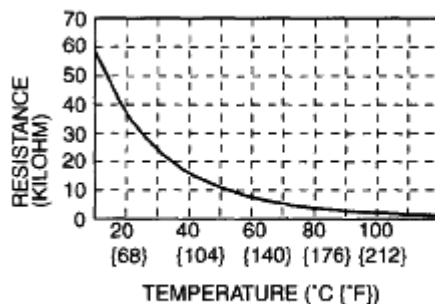

ac9uuw00000141

**Fig. 37: Cylinder Head Temperature Sensor Characteristics Graph**  
 Courtesy of MAZDA MOTORS CORP.

### CIRCUIT OPEN/SHORT INSPECTION



## 2007 Mazda CX-9 Grand Touring

2007 ENGINE PERFORMANCE Control System (MZI-3.5) - CX-9

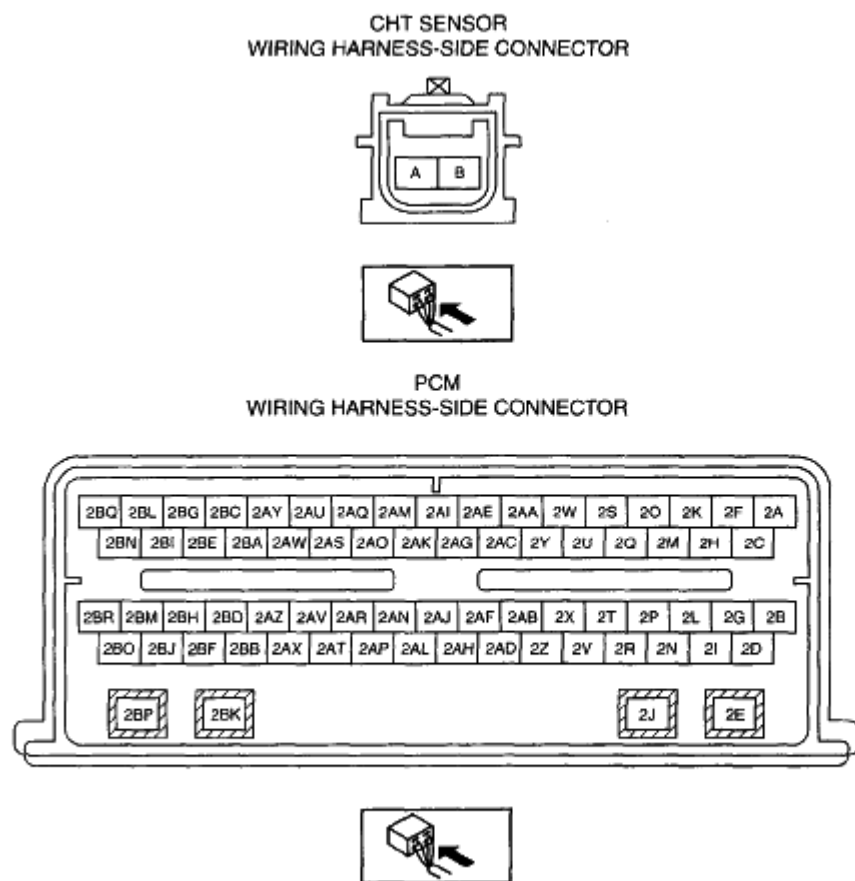

ac9uuw0000989

**Fig. 38: Identifying CHT Sensor & PCM Related Connector Terminals**  
Courtesy of MAZDA MOTORS CORP.

1. Disconnect the PCM connector. (See **PCM REMOVAL/INSTALLATION [MZI-3.5].**)
2. Inspect the following wiring harnesses for open or short. (Continuity inspection)

### Open circuit

- If there is no continuity, the circuit is open. Repair or replace the wiring harness.
  - CHT sensor terminal A and PCM terminal 2AL
  - CHT sensor terminal B and PCM terminal 2AN

### Short circuit

- If there is continuity, the circuit is shorted. Repair or replace the wiring harness.
  - CHT sensor terminal A and power supply
  - CHT sensor terminal A and body ground
  - CHT sensor terminal B and power supply

## FUEL TANK PRESSURE SENSOR INSPECTION [MZI-3.5]

### VOLTAGE INSPECTION

1. Remove the evaporative hose component. (see **FUEL TANK REMOVAL/INSTALLATION [MZI-3.5]** .)
2. Turn the ignition switch to the ON position.
3. Plug one end of the evaporative hose component and verify that the output voltage from the fuel tank pressure sensor changes when pressure is applied from the other hose end.
  - If it cannot be verified even though the related harnesses have no malfunction, replace the evaporative hose component.(see **FUEL TANK REMOVAL/INSTALLATION [MZI-3.5]** .)
  - If the monitor item status/specification (reference) is not within the specification, even though the resistance is within the specification, perform the "Circuit Open/Short Inspection".

### CIRCUIT OPEN/SHORT INSPECTION

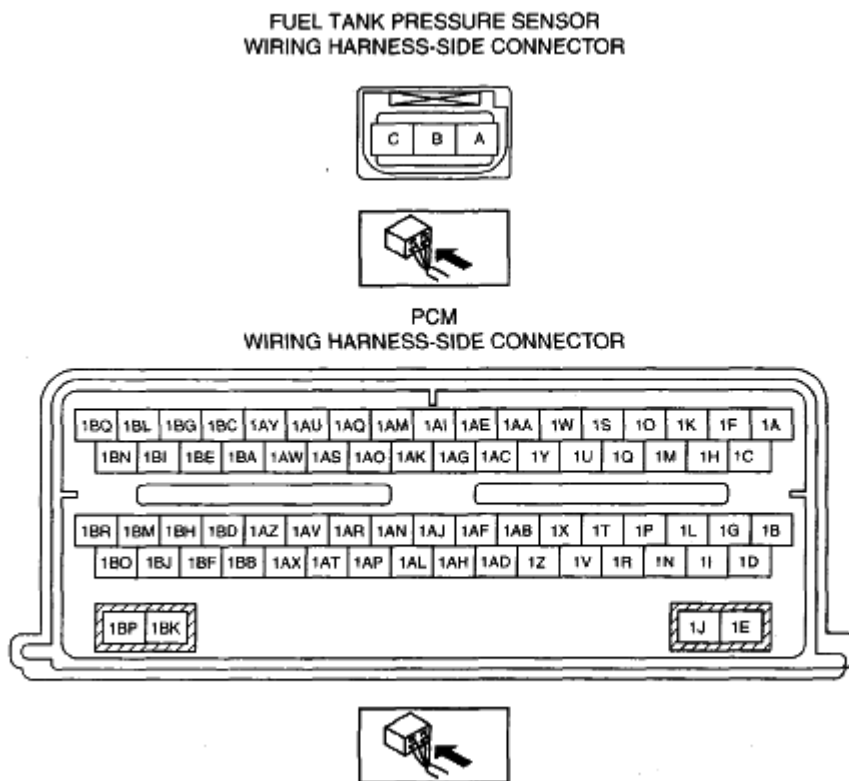

ac9uww00001131

**Fig. 39: Identifying Fuel Tank Pressure Sensor & PCM Related Connector Terminals**  
Courtesy of MAZDA MOTORS CORP.

1. Disconnect the PCM connector. (See **PCM REMOVAL/INSTALLATION [MZI-3.5]**.)
2. Disconnect the fuel tank pressure sensor connector.
3. Inspect the following wiring harnesses for open or short. (Continuity inspection)

## 2007 Mazda CX-9 Grand Touring

2007 ENGINE PERFORMANCE Control System (MZI-3.5) - CX-9

### Open circuit

- If there is no continuity, the circuit is open. Repair or replace the wiring harness.
  - Fuel tank pressure sensor terminal A and PCM terminal 1AB
  - Fuel tank pressure sensor terminal B and PCM terminal 1AL
  - Fuel tank pressure sensor terminal C and PCM terminal 1U

### Short circuit

- If there is continuity, the circuit is shorted. Repair or replace the wiring harness.
  - Fuel tank pressure sensor terminal A and power supply
  - Fuel tank pressure sensor terminal A and body ground
  - Fuel tank pressure sensor terminal B and power supply
  - Fuel tank pressure sensor terminal C and body ground