

## 2007 ENGINE PERFORMANCE

## On-Board Diagnostic (MZI-3.5) - CX-9

## FOREWORD [MZI-3.5]

- When the customer reports a vehicle malfunction, check the malfunction indicator lamp (MIL) indication and diagnostic trouble code (DTC), then diagnose the malfunction according to following flowchart.
  - If the DTC exists, diagnose the applicable DTC inspection. (See **DTC TABLE [MZI-3.5]**.)
  - If the DTC does not exist and the MIL does not illuminate, diagnose the applicable symptom troubleshooting.

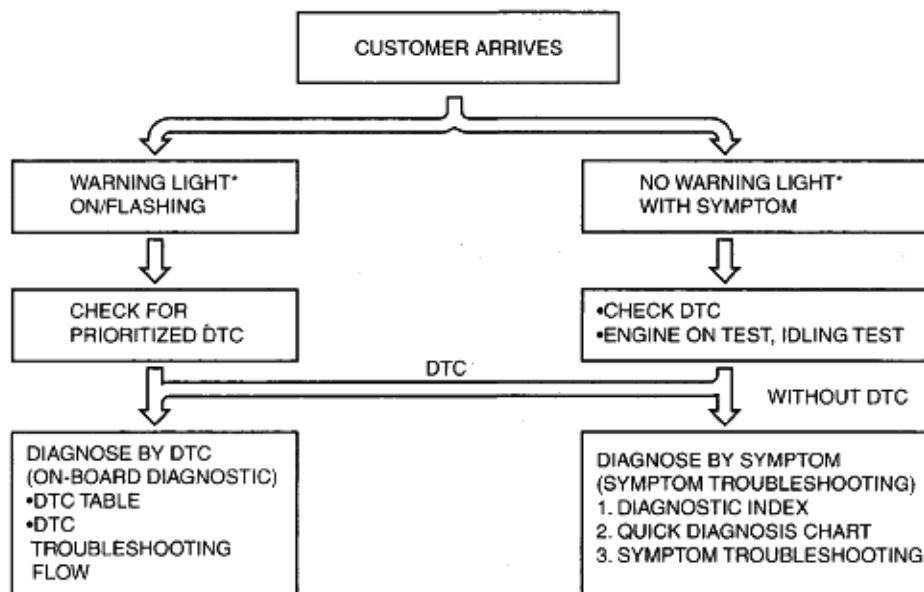

atrasaw00000607

**Fig. 1: Customer Reports Chart**  
Courtesy of MAZDA MOTORS CORP.

## ON-BOARD DIAGNOSTIC TEST [MZI-3.5]

## DTC READING PROCEDURE

1. Connect the M-MDS to the DLC-2.
2. After the vehicle is identified, select the following items from the initial screen of the M-MDS.
  - When using the IDS (laptop PC)
    1. Select the "Toolbox" tab.
    2. Select "Self Test".
    3. Select "Modules".
    4. Select "PCM".

- When using the PDS (Pocket PC)
  1. Select "Module Tests".
  2. Select "PCM".
  3. Select "Self Test".
- 3. Then, select the "Retrieve CMDTCs" and perform procedures according to directions on the M-MDS screen.
- 4. Verify the DTC according to the directions on the M-MDS screen.
  - If any DTCs are displayed, perform troubleshooting according to the corresponding DTC inspection.
- 5. After completion of repairs, clear all DTCs stored in the PCM, while referring to "AFTER REPAIR PROCEDURE".

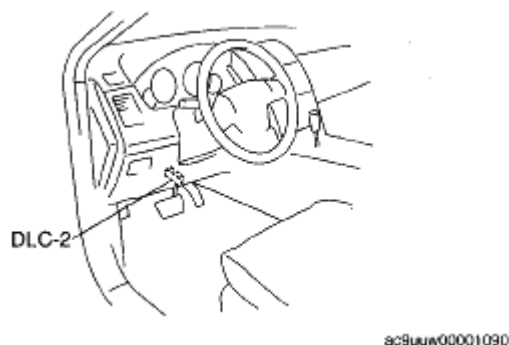

**Fig. 2: Identifying DLC-2 Connector**  
Courtesy of MAZDA MOTORS CORP.

### **PENDING TROUBLE CODE ACCESS PROCEDURE**

1. Connect the M-MDS to the DLC-2.
2. After the vehicle is identified, select the following items from the initial screen of the M-MDS.
  - When using the IDS (laptop PC)
    1. Select the "Toolbox" tab.
    2. Select "Self Test".
    3. Select "Modules".
    4. Select "PCM".
  - When using the PDS (Pocket PC)
    1. Select "Module Tests".
    2. Select "PCM".
    3. Select "Self Test".
3. Then, select the "Retrieve CMDTCs" and perform procedures according to directions on the M-MDS screen.
4. Retrieve the pending trouble codes according to the directions on the M-MDS screen.

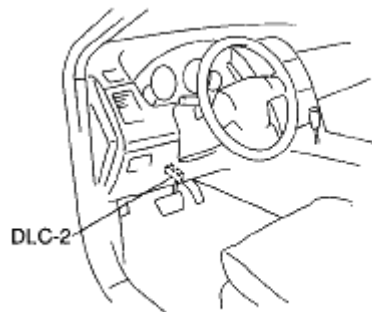

ac9uuw00001090

**Fig. 3: Identifying DLC-2 Connector**  
Courtesy of MAZDA MOTORS CORP.

### **FREEZE FRAME PID DATA ACCESS PROCEDURE**

1. Connect the M-MDS to the DLC-2.
2. After the vehicle is identified, select the following items from the initial screen of the M-MDS.
  - When using the IDS (laptop PC)
    1. Select the "Toolbox" tab.
    2. Select "Self Test".
    3. Select "Modules".
    4. Select "PCM".
  - When using the PDS (Pocket PC)
    1. Select "Module Tests".
    2. Select "PCM".
    3. Select "Self Test".
3. Then, select the "Retrieve CMDTCs" and perform procedures according to directions on the M-MDS screen.
4. Retrieve the freeze frame PID data according to the directions on the M-MDS screen.

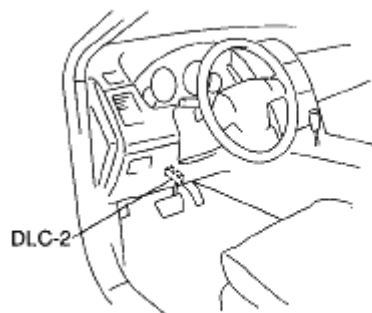

ac9uuw00001090

**Fig. 4: Identifying DLC-2 Connector**  
Courtesy of MAZDA MOTORS CORP.

**ON-BOARD SYSTEM READINESS TESTS ACCESS PROCEDURE**

1. Connect the M-MDS to the DLC-2.
2. After the vehicle is identified, select the following items from the initial screen of the M-MDS.
  - When using the IDS (laptop PC)
    1. Select the "Toolbox" tab.
    2. Select "Powertrain".
    3. Select "OBD Test Modes".
    4. Select "Mode 1 Powertrain Data".
    5. Select "PCM".
  - When using the PDS (Pocket PC)
    1. Select "OBDII Modes".
    2. Select "Mode 1 Powertrain Data".
    3. Select "PCM".
3. Then, select the "\*\*\*\*SUP" and "\*\*\*EVAL" PIDs in the PID selection screen.
4. Monitor those PIDs and check it system monitor is completed.

**NOTE:**

- If the on-board system readiness tests are not completed the PCM stores DTC P1000.

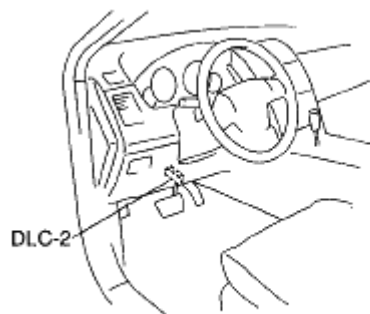

ac9uuw00001090

**Fig. 5: Identifying DLC-2 Connector**  
Courtesy of MAZDA MOTORS CORP.

**PID/DATA MONITOR AND RECORD PROCEDURE****NOTE:**

- The PID/DATA MONITOR function monitors the calculated value of the input/output signals in the PCM. Therefore, an output device malfunction is not directly indicated as a malfunction of the monitored value for the output device. If a monitored value of an output device is out of specification, inspect the monitored value of the input device related to the output control.

## 2007 Mazda CX-9 Grand Touring

2007 ENGINE PERFORMANCE On-Board Diagnostic (MZI-3.5) - CX-9

1. Connect the M-MDS to the DLC-2.
2. After the vehicle is identified, select the following items from the initial screen of the M-MDS.
  - When using the IDS (laptop PC)
    1. Select the "Toolbox" tab.
    2. Select "DataLogger".
    3. Select "Modules".
    4. Select "PCM".
  - When using the PDS (Pocket PC)
    1. Select "Module Tests".
    2. Select "PCM".
    3. Select "DataLogger".
3. Select the PID from the PID table.
4. Verify the test results according to detections on the screen.

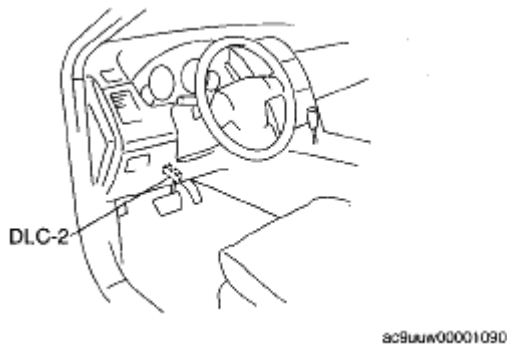

**Fig. 6: Identifying DLC-2 Connector**  
Courtesy of MAZDA MOTORS CORP.

### PID/DATA MONITOR CHART

PID Name	Description	Unit
AAT	Indicate the ambient air temperature	°C
AC_REQ	A/C request signal	Off/On
ACCS	A/C relay	Off/On
ALTF	Generator field coil control duty value	%
APP	Accelerator pedal position	%
APP1	APP sensor No.1	% V
APP2	APP sensor No.2	% V
APP3	APP sensor No.3	% V
ARPMDES	Target engine speed	RPM

## 2007 Mazda CX-9 Grand Touring

2007 ENGINE PERFORMANCE On-Board Diagnostic (MZI-3.5) - CX-9

AXLE	Axle ratio	-
BARO	Barometric pressure	Pa
BOO	Brake switch	Off/On
BPA	Brake pressure applied switch	Off/On
CATT11_DSD	Estimated catalytic converter temperature (RH)	°C
CATT21_DSD	Estimated catalytic converter temperature (LH)	°C
CHRGLP	Generator warning light	Off/On
CHT	CHT sensor	°C
		V
COLP	Refrigerant pressure switch (middle)	Off/On
DTCCNT	Number of DTCs detected	-
ECT	Engine coolant temperature	°C
EQ_RAT11_DSD	Desired equivalence ratio (lambda)	-
ETC_ACT	Electronic throttle control actual	°
ETC_DSD	Electronic throttle control desired	%
		°
EVAPCP	Purge solenoid valve duty value	%
EVAPCV	CV solenoid valve	Off/On
EVMV	Evaporative Emission Vapor Management valve	mA
FAN_DUTY	Cooling fan control	%
FLI	Fuel level	%
FP	Fuel pump relay	Off/On
FPM	Fuel pump monitor	Off/On
FTP	Fuel tank pressure sensor	V
FTP_H2O	Fuel tank pressure (inches of water column)	-
FUELSYS1	Fuel system loop status (RH)	OL/CL/OL-Drive/OL-Fault/CL-Fault
GENVDS	Generator voltage desired	V
HTR11	Front HO2S heater (RH)	Off/On
HTR12	Rear HO2S heater (RH)	Off/On
HTR21	Front HO2S heater (LH)	Off/On
HTR22	Rear HO2S heater (LH)	Off/On
IAT	IAT sensor	°C
		V
INGEAR	Load/no load condition	Off/On
LOAD	Engine load	%
LONGFT1	Long term fuel trim (RH)	%
LONGFT2	Long term fuel trim (LH)	%
MAF	MAF sensor	g/s
		V
MFF_IAT	Intake air temperature at the time of misfire	°C

## 2007 Mazda CX-9 Grand Touring

2007 ENGINE PERFORMANCE On-Board Diagnostic (MZI-3.5) - CX-9

MFF_LOAD	Engine load at the time of misfire	%
MFF_RNTM	Engine running time at time of misfire	ms
MFF_RPM	Engine speed at the time of misfire	RPM
MFF_SOAK	Engine off soak time prior to misfire	ms
MFF_TP	Throttle position at the time of misfire	V
MFF_TRIP	Number of trips since the time of misfire	-
MFF_VSS	Vehicle speed at the time of misfire	KPH
MIL	Malfunction indicator lamp	Off/On
MIL_DIS	Travelled distance since the MIL illuminated	km
O2S11	Front HO2S (RH)	V
O2S12	Rear HO2S (RH)	V
O2S21	Front HO2S (LH)	V
O2S22	Rear HO2S (LH)	V
PCVHC	PCV valve heater control	%
PSP	Power steering pressure switch	Low/High
RO2FT1	Rear HO2S fuel trim (RH)	-
RO2FT2	Rear HO2S fuel trim (LH)	-
RPM	Engine speed	RPM
SC_CANCEL	Speed control cancel switch	Inactive/Active
SC_OFF	Cruise control OFF switch	Inactive/Active
SC_ON	Cruise control ON switch	Inactive/Active
SC_RES	Cruise resume switch	Inactive/Active
SC_SET-	Cruise coast switch	Inactive/Active
SC_SET+	Cruise set/acceleration switch	Inactive/Active
SCCS	Speed control command switch	V
SHRTFT1	Short term fuel trim (RH)	%
SHRTFT11	Front short term fuel trim (RH)	%
SHRTFT2	Short term fuel trim (LH)	%
SHRTFT21	Front short term fuel trim (LH)	%
SPARKADV	Ignition timing	°
SPKDUR_1	Spark duration of cylinder No.1	sec
SPKDUR_2	Spark duration of cylinder No.2	sec
SPKDUR_3	Spark duration of cylinder No.3	sec
SPKDUR_4	Spark duration of cylinder No.4	sec
SPKDUR_5	Spark duration of cylinder No.5	sec
SPKDUR_6	Spark duration of cylinder No.6	sec
SPRK_ACT	Actual ignition timing	°
TIRESIZE	Tire revolution per mile	-
TP_REL	Relative throttle position	%
TP1	TP sensor No.1	%
		V

## 2007 Mazda CX-9 Grand Touring

2007 ENGINE PERFORMANCE On-Board Diagnostic (MZI-3.5) - CX-9

TP2	TP sensor No. 2	%
		V
VPWR	Battery voltage	V
VSS	Vehicle speed	KPH
VT ACT1	Actual valve timing (RH)	°
VT ACT2	Actual valve timing (LH)	°
VT DIFF1	Difference between target and actual valve timing (RH)	°
VT DIFF2	Difference between target and actual valve timing (LH)	°
VT DUTY1	Oil control valve duty value (RH)	%
VT DUTY2	Oil control valve duty value (LH)	%

### DIAGNOSTIC MONITORING TEST RESULTS ACCESS PROCEDURE

1. Connect the M-MDS to the DLC-2.
2. After the vehicle is identified, select the following items from the initial screen of the M-MDS.
  - When using the IDS (laptop PC)
    1. Select the "Toolbox" tab.
    2. Select "Powertrain".
    3. Select "OBD Test Modes".
    4. Select "Mode 6 On-Board Test Results".
  - When using the PDS (Pocket PC)
    1. Select "OBDII Modes".
    2. Select "Mode 6 On-Board Test Results".
3. Verify the PID data according to the directions on the screen.

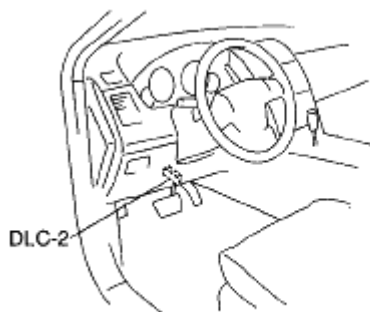

ac9uuw00001090

**Fig. 7: Identifying DLC-2 Connector**  
Courtesy of MAZDA MOTORS CORP.

### SIMULATION FUNCTION PROCEDURE



1. Connect the M-MDS to the DLC-2.
2. After the vehicle is identified, select the following items from the initial screen of the M-MDS.
  - When using the IDS (laptop PC)
    1. Select the "Toolbox" tab.
    2. Select "DataLogger".
    3. Select "Modules".
    4. Select "PCM".
  - When using the PDS (Pocket PC)
    1. Select "Module Tests".
    2. Select "PCM".
    3. Select "DataLogger".
3. Select the simulation items from the PID table.
4. Perform the simulation function, inspect the operations for each parts.
  - If there is no operation sound from the relay, motor, and solenoid after the simulation function inspection is performed, it is possible that there is an open or short circuit in the wiring harness, relay, motor or solenoid, or sticking and operation malfunction.

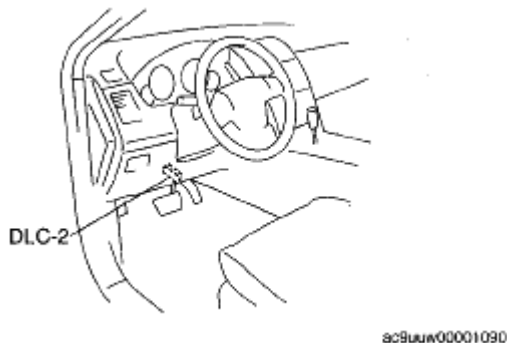
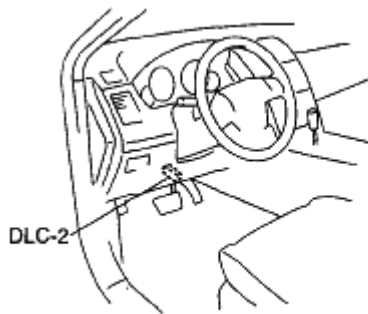

**Fig. 8: Identifying DLC-2 Connector**  
Courtesy of MAZDA MOTORS CORP.

## **AFTER REPAIR PROCEDURE [MZI-3.5]**

1. Connect the M-MDS to the DLC-2.
2. After the vehicle is identified, select the following items from the initial screen of the M-MDS.
  - When using the IDS (laptop PC)
    1. Select the "Toolbox" tab.
    2. Select "Self Test".
    3. Select "Modules".
    4. Select "PCM".
    5. Select "Retrieve CMDTCs".

- When using the PDS (Pocket PC)
  1. Select "Module Tests".
  2. Select "PCM".
  3. Select "Self Test".
  4. Select "Retrieve CMDTCs".
- 3. Verify the DTC according to the directions on the M-MDS screen.
- 4. Press the clear button on the DTC screen to clear the DTC.
- 5. Verify that no DTCs are displayed.



ac9Uuw00001450

**Fig. 9: Identifying DLC-2 Connector**  
Courtesy of MAZDA MOTORS CORP.

## **KOEO/KOER SELF TEST [MZI-3.5]**

1. Connect the M-MDS to the DLC-2.
2. After the vehicle is identified, select the following items from the initial screen of the M-MDS.
  - When using the IDS (laptop PC)
    1. Select the "Toolbox" tab.
    2. Select "Self Test".
    3. Select "Modules".
    4. Select "PCM".
  - When using the PDS (Pocket PC)
    1. Select "Module Tests".
    2. Select "PCM".
    3. Select "Self Test".
3. Then, select the "KOEO On Demand Self Test" or "KOER On Demand Self Test" and perform procedures according to directions on the M-MDS screen.
4. Verify the DTC according to the directions on the M-MDS screen.
  - If any DTCs are displayed, perform troubleshooting according to the corresponding DTC inspection.

5. After completion of repairs, clear all DTCs stored in the PCM, while referring to "AFTER REPAIR PROCEDURE".

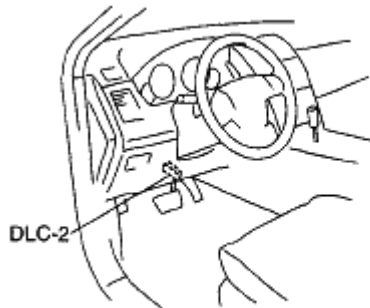

ac8UJW00001451

**Fig. 10: Identifying DLC-2 Connector**  
Courtesy of MAZDA MOTORS CORP.

## OBD-II DRIVE MODE [MZI-3.5]

- The following procedure is designed to execute and complete the OBD-II monitors and to clear the DTC P1000.
- To complete a specific monitor for repair verification, follow Steps 1 through 4, then continue using the steps indicated by the appropriate monitor.
- The Drive Mode is performed using the M-MDS.

### CAUTION:

- While performing the Drive Mode, always operate the vehicle in a safe and lawful manner.
- When the M-MDS is used to observe monitor system status while driving, be sure to have another technician with you, or record the data in the M-MDS using the PID/DATA MONITOR AND RECORD function and inspect later.

### NOTE:

- If the OBD-II system inspection is not completed during the Drive Mode, the following causes are considered:
  - The OBD-II system detects a malfunction.
  - The Drive Mode procedure is not completed correctly.
- Disconnecting the battery will reset the memory. Do not disconnect the battery during and after Drive Mode.
- The M-MDS can be used at anytime through the course of the Drive Mode to monitor the completion status. Monitoring can be done by viewing the ON BOARD SYSTEM READINESS menu.
- Most OBD-II monitors will complete more readily using a "steady foot" driving style during cruise or acceleration. Operating the throttle in a "smooth" fashion will minimize the time required for monitor completion.

## 2007 Mazda CX-9 Grand Touring

2007 ENGINE PERFORMANCE On-Board Diagnostic (MZI-3.5) - CX-9

- The fuel tank level should be between 1/2 and 3/4 full with 3/4 full being the most desirable.
- The evaporative emission system monitor can only operate during the first 30 min of the engine operation. When executing the procedure for the evaporative emission system monitor, remain in part throttle position and drive in a smooth fashion to minimize "fuel slosh".
- When bypassing the EVAP soak times, the PCM must remain powered (ignition switch to the ON position) after clearing the continuous DTCs and relearning emission diagnostic information.

### OBD-II DRIVE MODE CHART

OBD-II monitor exercised	Step	Procedure	Purpose
Drive Mode Preparation	1	<p><b>NOTE:</b></p> <ul style="list-style-type: none"> <li>• To bypass the EVAP soak timer (normally 6 hours), the PCM must remain powered after clearing the continuous DTCs and resetting the emission monitors information in the PCM.</li> <li>• Connect the M-MDS to the DLC-2.</li> <li>• Turn the ignition switch to the ON position (Engine off).</li> <li>• Turn the ignition switch off then to the ON position, (Engine off).</li> <li>• Select the appropriate vehicle and engine qualifier.</li> <li>• Clear the continuous DTCs and reset the emission monitors information in the PCM.</li> </ul> <p><b>NOTE:</b></p> <ul style="list-style-type: none"> <li>• The following events occur when the continuous DTCs and the emission monitors information is cleared from the PCM:                             <ul style="list-style-type: none"> <li>○ Clears the number of DTCs and the DTCs.</li> <li>○ Clears the freeze frame data.</li> <li>○ Clears the diagnostic monitoring test</li> </ul> </li> </ul>	Bypasses the engine soak timer. Resets the OBD-II monitor status.

## 2007 Mazda CX-9 Grand Touring

2007 ENGINE PERFORMANCE On-Board Diagnostic (MZI-3.5) - CX-9

		<p><b>results.</b></p> <ul style="list-style-type: none"> <li>○ Clears the status of the OBD-II system monitors is reset.</li> <li>○ Sets DTC P1000.</li> </ul>	
	2	<ul style="list-style-type: none"> <li>● Start the engine without turning the ignition switch off.</li> </ul>	
	3	<ul style="list-style-type: none"> <li>● Idle the engine for <b>15 s.</b></li> <li>● Drive at <b>64 km/h {40 mph}</b> until the ECT is <b>76.7 °C {170 °F}</b> or <b>more.</b></li> </ul>	
Prep for Monitor Entry	4	<p><b>NOTE:</b></p> <ul style="list-style-type: none"> <li>● When the IAT is not within <b>4.4-37.8 °C {40-100 °F}</b> or the altitude is above <b>2,438 m {8,000 ft}</b> , the <b>EVAP</b> monitor will not run.</li> <li>● Is the IAT within <b>4.4-37.8 °C {40-100 °F}</b> ? <ul style="list-style-type: none"> <li>○ If not within the specification, complete the following steps but, note that step 13 will be required to "bypass" the EVAP monitor.</li> </ul> </li> </ul>	Engine warm-up and provides IAT input to the PCM.
HO2S	5	<ul style="list-style-type: none"> <li>● Cruise at <b>64 km/h {40 mph}</b> for up to <b>5 min.</b></li> </ul>	Executes the HO2S monitor.
EVAP	6	<p><b>NOTE:</b></p> <ul style="list-style-type: none"> <li>● To initiate the monitor, the throttle should be at part throttle, <b>Evaporative Emissions Duty Cycle</b> must be more than <b>75%</b>, and <b>FLI</b> must be <b>15-85%</b>, and for fuel tanks over 25 gallons <b>Fuel Level Indicator Input</b> must be <b>30-85%</b>.</li> <li>● Cruise at <b>64-89 km/h {40-55 mpr}</b> for <b>10 min.</b></li> </ul>	Executes the EVAP emission monitor.
Catalyst	7	<ul style="list-style-type: none"> <li>● Stop the vehicle and go to traffic conditions.</li> <li>● Include five different constant cruise speeds, ranging from <b>32-89 km/h {20-55 mph}</b> over a <b>10 min</b> period.</li> </ul>	Executes the catalyst efficiency monitor.

## 2007 Mazda CX-9 Grand Touring

2007 ENGINE PERFORMANCE On-Board Diagnostic (MZI-3.5) - CX-9

CCM (Engine)	8	<ul style="list-style-type: none"> <li>• Stop the vehicle.</li> <li>• Idle the engine for <b>2 min</b> with the selector lever in the D range.</li> </ul>	Executes the idle air control portion of the CCM.
CCM (Transaxle)	9	<ul style="list-style-type: none"> <li>• Stop the vehicle.</li> <li>• In overdrive, moderately accelerate to <b>81 km/h {50 mph}</b> and cruise for <b>15 s or more</b>.</li> <li>• Stop the vehicle and repeat without overdrive to <b>64 km/h {40 mph}</b> cruising for <b>30 s or more</b>.</li> <li>• While at <b>64 km/h {40 mph}</b> , activate overdrive and accelerate to <b>81 km/h {50 mph}</b> and cruise for <b>15 s or more</b>.</li> <li>• Stop the vehicle for <b>20 s or more</b>.</li> <li>• Repeat Step 9 five times.</li> </ul>	Executes the transaxle portion of the CCM.
Misfire and Fuel	10	<ul style="list-style-type: none"> <li>• Stop the vehicle.</li> <li>• Accelerate to <b>97 km/h {60 mph}</b>.</li> <li>• Decelerate at closed throttle until reaching <b>64 km/h {40 mph}</b> (no brakes).</li> <li>• Repeat 3 times.</li> </ul>	Allows learning for the misfire monitor.
Readiness Check	11	<ul style="list-style-type: none"> <li>• Access the ON BOARD SYSTEM READINESS to verify the OBD-II monitoring status.                             <ul style="list-style-type: none"> <li>○ If completed, all of the OBD-II monitoring status items change from non-completed to completed.</li> <li>○ If not completed, go to the next step.</li> </ul> </li> </ul>	Determines if any monitor has not been completed.
Pending Code Check and EVAP Monitor Bypass Check	12	<ul style="list-style-type: none"> <li>• Verify that no pending code has been stored. If any pending code has been stored, perform the appropriate DTC inspection.  (See <b><u>DTC TABLE [MZI-3.5]</u></b>.)</li> <li>• Otherwise, return any incomplete monitor.</li> </ul> <p style="margin-top: 10px;"><b>NOTE:</b></p>	<p><b>NOTE:</b></p> <ul style="list-style-type: none"> <li>• <b>The DTC P1000 will be stored if any of the OBD-II monitors does not complete.</b></li> </ul> <p>Determines if a pending code is preventing the clearing of the DTC P1000.</p>

## 2007 Mazda CX-9 Grand Touring

2007 ENGINE PERFORMANCE On-Board Diagnostic (MZI-3.5) - CX-9

		<ul style="list-style-type: none"> <li>If the EVAP monitor is not completed and the IAT was out of the 4.4-37.8 °C {40-100 °F} range, or the altitude is above 2,438 m {8,000 ft} , the "EVAP Monitor Bypass" procedure must be followed.</li> </ul>	
		<ul style="list-style-type: none"> <li>Perform the "EVAP Monitor Bypass" procedure.</li> </ul>	
EVAP Monitor Bypass	13	<ul style="list-style-type: none"> <li>Leave the vehicle for <b>8 h.</b></li> <li>Go to Step 2 then perform from Step 2 to 11.</li> </ul>	Allows the "bypass" counter to increment to two.

### DIAGNOSTIC MONITORING TEST RESULTS [MZI-3.5]

- The purpose of this test mode is to confirm the result of OBD-II monitor diagnostic test results. The result values stored when particular monitor is completed are displayed. If the monitor is not completed, initial value is displayed.

#### DIAGNOSTIC MONITORING TEST RESULTS CHART

TEST ID	Description	Related system	Unit
10: 01: 01	Front HO2S (RH) Switchpoint	HO2S	V
10: 01: 80	Front HO2S (RH) Voltage Amplitude		V
10: 01: 81	Front HO2S (RH) Heater Current		A
10: 05: 01	Front HO2S (LH) Switchpoint		V
10: 05: 80	Front HO2S (LH) Voltage Amplitude		V
10: 05: 81	Front HO2S (LH) Heater Current		A
10: 02: 01	Rear HO2S (RH) Switchpoint		V
10: 02: 81	Rear HO2S (RH) Heater Current		A
10: 06: 01	Rear HO2S (LH) Switchpoint		V
10: 06: 81	Rear HO2S (LH) Heater Current		A
10: 21: 80	HO2S (Front) and HO2S (Rear)	Catalyst	-
10: 22: 80	switching time ratio		-
10: 3A: 80	Phase 0 Excessive vacuum limit	EVAP	Pa
10: 3A: 81	Phase 4 Purge Valve stuck open limit		Pa
10: 3A: 82	Phase 0 Gross Leak Limit		Pa
10: 3B: 80	Phase 2 0.040" leak check vacuum bleedup and maximum 0.040" leak threshold		Pa
10: A1: 80	Type A Misfire Rate (engine 200 rpm)		%
10: A1: 81	Type B Misfire Rate (engine 1000 rpm)		%

## 2007 Mazda CX-9 Grand Touring

2007 ENGINE PERFORMANCE On-Board Diagnostic (MZI-3.5) - CX-9

10: A1: 82	Highest Misfire Rate Type A (engine 200 rpm)	Misfire	%
10: A1: 83	Highest Misfire Rate Type B (engine 1000 rpm)		%
10: A1: 84	Inferred Catalyst Mid-Bed Temperature		°C
10: A2: 0B	Cylinder No.1 average misfire counts for last 10 DC		-
10: A2: 0C	Cylinder No.1 misfire counts for last/current DC		-
10: A2: 80	Cylinder No.1 Type A Misfire Rate (engine 200 rpm)		%
10: A2: 81	Cylinder No.1 Type B Misfire Rate (engine 1000 rpm)		%
10: A3: 0B	Cylinder No.2 average misfire counts for last 10 DC		-
10: A3: 0C	Cylinder No.2 misfire counts for last/current DC		-
10: A3: 80	Cylinder No.2 Type A Misfire Rate (engine 200 rpm)		%
10: A3: 81	Cylinder No.2 Type B Misfire Rate (engine 1000 rpm)		%
10: A4: 0B	Cylinder No.3 average misfire counts for last 10 DC		-
10: A4: 0C	Cylinder No.3 misfire counts for last/current DC		-
10: A4: 80	Cylinder No.3 Type A Misfire Rate (engine 200 rpm)		%
10: A4: 81	Cylinder No.3 Type B Misfire Rate (engine 1000 rpm)		%
10: A5: 0B	Cylinder No.4 average misfire counts for last 10 DC		-
10: A5: 0C	Cylinder No.4 misfire counts for last/current DC		-
10: A5: 80	Cylinder No.4 Type A Misfire Rate (engine 200 rpm)		%
10: A5: 81	Cylinder No.4 Type B Misfire Rate (engine 1000 rpm)		%
10: A6: 0B	Cylinder No.5 average misfire counts for last 10 DC		-
10: A6: 0C	Cylinder No.5 misfire counts for last/current DC	-	
10: A6: 80	Cylinder No.5 Type A Misfire Rate (engine 200 rpm)	%	
10: A6: 81	Cylinder No.5 Type B Misfire Rate	%	



## 2007 Mazda CX-9 Grand Touring

2007 ENGINE PERFORMANCE On-Board Diagnostic (MZI-3.5) - CX-9

	(engine 1000 rpm)	
10: A7: 0B	Cylinder No.6 average misfire counts for last 10 DC	-
10: A7: 0C	Cylinder No.6 misfire counts for last/current DC	-
10: A7: 80	Cylinder No.6 Type A Misfire Rate (engine 200 rpm)	%
10: A7: 81	Cylinder No.6 Type B Misfire Rate (engine 1000 rpm)	%

### DTC TABLE [MZI-3.5]

#### DTC CHART

DTC	Description	MIL	DC	Action
B1342	PCM malfunction	OFF	-	(See <b>DTC B1342 [MZI-3.5].</b> )
P0010	CMP actuator circuit open (RH)	ON	2	(See <b>DTC P0010 [MZI-3.5].</b> )
P0011	CMP timing over-advanced (RH)	ON	2	(See <b>DTC P0011 [MZI-3.5].</b> )
P0012	CMP timing over-retarded (RH)	ON	2	(See <b>DTC P0012 [MZI-3.5].</b> )
P0016	CKP-CMP sensor (RH) correlation	ON	2	(See <b>DTC P0016, P0018 [MZI-3.5].</b> )
P0018	CKP-CMP sensor (LH) correlation	ON	2	(See <b>DTC P0016, P0018 [MZI-3.5].</b> )
P0020	CMP actuator circuit open (LH)	ON	2	(See <b>DTC P0020 [MZI-3.5].</b> )
P0021	CMP timing over-advanced (LH)	ON	2	(See <b>DTC P0021 [MZI-3.5].</b> )
P0022	CMP timing over-retarded (LH)	ON	2	(See <b>DTC P0022 [MZI-3.5].</b> )
P0040	Front HO2S (LH/RH) signals swapped	OFF	1	(See <b>DTC P0040, P0041 [MZI-3.5].</b> )
P0041	Rear HO2S (LH/RH) signals swapped	OFF	1	(See <b>DTC P0040, P0041 [MZI-3.5].</b> )
P0053	Front HO2S (RH) heater resistance	ON	2	(See <b>DTC P0053, P0054, P0059, P0060 [MZI-3.5].</b> )
P0054	Rear HO2S (RH) heater resistance	ON	2	(See <b>DTC P0053, P0054, P0059, P0060 [MZI-3.5].</b> )
P0059	Front HO2S (LH) heater resistance	ON	2	(See <b>DTC P0053, P0054, P0059, P0060 [MZI-3.5].</b> )
P0060	Rear HO2S (LH) heater resistance	ON	2	(See <b>DTC P0053, P0054, P0059, P0060 [MZI-3.5].</b> )
P0068	MAP/MAF-throttle position correlation	ON	2	(See <b>DTC P0068 [MZI-3.5].</b> )
P0102	MAF circuit low input	ON	2	(See <b>DTC P0102 [MZI-3.5].</b> )
P0103	MAF circuit high input	ON	2	(See <b>DTC P0103 [MZI-3.5].</b> )
P0104	MAF circuit intermittent/erratic	OFF	1	(See <b>DTC P0104 [MZI-3.5].</b> )
P0111	IAT sensor circuit range/performance	ON	2	(See <b>DTC P0111 [MZI-3.5].</b> )

## 2007 Mazda CX-9 Grand Touring

2007 ENGINE PERFORMANCE On-Board Diagnostic (MZI-3.5) - CX-9

P0112	IAT sensor circuit low input	ON	2	(See <b>DTC P0112 [MZI-3.5].</b> )
P0113	IAT sensor circuit high input	ON	2	(See <b>DTC P0113 [MZI-3.5].</b> )
P0114	IAT sensor Intermittent/erratic	OFF	1	(See <b>DTC P0114 [MZI-3.5].</b> )
P0116	CHT sensor circuit range/performance	ON	2	(See <b>DTC P0116 [MZI-3.5].</b> )
P0119	CHT sensor circuit intermittent/erratic	OFF	1	(See <b>DTC P0119 [MZI-3.5].</b> )
P0122	TP sensor No.1 circuit low input	ON <sup>(2)</sup>	2	(See <b>DTC P0122 [MZI-3.5].</b> )
P0123	TP sensor No.1 circuit high input	N <sup>(2)</sup>	2	(See <b>DTC P0123 [MZI-3.5].</b> )
P0128	Coolant thermostat (coolant temp below thermostat regulating temperature)	ON	2	(See <b>DTC P0128 [MZI-3.5].</b> )
P0132	Front HO2S (RH) circuit high voltage	ON	2	(See <b>DTC P0132, P0138, P0152, P0158 [MZI-3.5].</b> )
P0133	Front HO2S (RH) circuit slow response	ON	2	(See <b>DTC P0133, P0139, P0153, P0159 [MZI-3.5].</b> )
P0135	Front HO2S (RH) heater circuit	ON	2	(See <b>DTC P0135, P0141, P0155, P0161 [MZI-3.5].</b> )
P0138	Rear HO2S (RH) circuit high voltage	ON	2	(See <b>DTC P0132, P0138, P0152, P0158 [MZI-3.5].</b> )
P0139	Rear HO2S (RH) circuit slow response	ON	2	(See <b>DTC P0133, P0139, P0153, P0159 [MZI-3.5].</b> )
P0141	Rear HO2S (RH) heater circuit	ON	2	(See <b>DTC P0135, P0141, P0155, P0161 [MZI-3.5].</b> )
P0148	Fuel delivery error	OFF	1	(See <b>DTC P0148 [MZI-3.5].</b> )
P0152	Front HO2S (LH) circuit high voltage	ON	2	(See <b>DTC P0132, P0138, P0152, P0158 [MZI-3.5].</b> )
P0153	Front HO2S (LH) circuit slow response	ON	2	(See <b>DTC P0133, P0139, P0153, P0159 [MZI-3.5].</b> )
P0155	Front HO2S (LH) heater circuit	ON	2	(See <b>DTC P0135, P0141, P0155, P0161 [MZI-3.5].</b> )
P0158	Rear HO2S (LH) circuit high voltage	ON	2	(See <b>DTC P0132, P0138, P0152, P0158 [MZI-3.5].</b> )
P0159	Rear HO2S (LH) circuit slow response	ON	2	(See <b>DTC P0133, P0139, P0153, P0159 [MZI-3.5].</b> )
P0161	Rear HO2S (LH) heater circuit	ON	2	(See <b>DTC P0135, P0141, P0155, P0161 [MZI-3.5].</b> )
P0171	System too lean (RH)	ON	2	(See <b>DTC P0171, P0174 [MZI-3.5].</b> )
P0172	System too rich (RH)	ON	2	(See <b>DTC P0172, P0175 [MZI-3.5].</b> )
P0174	System too lean (LH)	ON	2	(See <b>DTC P0171, P0174 [MZI-3.5].</b> )
P0175	System too rich (LH)	ON	2	(See <b>DTC P0172, P0175 [MZI-3.5].</b> )
P0201	Injector circuit/open-cylinder No.1	ON	2	(See <b>DTC P0201 [MZI-3.5].</b> )

## 2007 Mazda CX-9 Grand Touring

2007 ENGINE PERFORMANCE On-Board Diagnostic (MZI-3.5) - CX-9

P0202	Injector circuit/open-cylinder No.2	ON	2	(See <b><u>DTC P0202 [MZI-3.5].</u></b> )
P0203	Injector circuit/open-cylinder No.3	ON	2	(See <b><u>DTC P0203 [MZI-3.5].</u></b> )
P0204	Injector circuit/open-cylinder No.4	ON	2	(See <b><u>DTC P0204 [MZI-3.5].</u></b> )
P0205	Injector circuit/open-cylinder No.5	ON	2	(See <b><u>DTC P0205 [MZI-3.5].</u></b> )
P0206	Injector circuit/open-cylinder No.6	ON	2	(See <b><u>DTC P0206 [MZI-3.5].</u></b> )
P0222	TP sensor No.2 circuit low input	ON <sup>(2)</sup>	2	(See <b><u>DTC P0222 [MZI-3.5].</u></b> )
P0223	TP sensor No.2 circuit high input	ON <sup>(2)</sup>	2	(See <b><u>DTC P0223 [MZI-3.5].</u></b> )
P0230	FP primary circuit	OFF	1	(See <b><u>DTC P0230 [MZI-3.5].</u></b> )
P0231	FP secondary circuit low	OFF	1	(See <b><u>DTC P0231 [MZI-3.5].</u></b> )
P0232	FP secondary circuit high	OFF	1	(See <b><u>DTC P0232 [MZI-3.5].</u></b> )
P0297	Vehicle over speed condition	OFF	1	(See <b><u>DTC P0297 [MZI-3.5].</u></b> )
P0300	Random misfire detected	ON	1	(See <b><u>DTC P0300 [MZI-3.5].</u></b> )
P0301	Cylinder No.1 misfire detected	ON	1	(See <b><u>DTC P0301, P0302, P0303, P0304, P0305, P0306, P0316 [MZI-3.5].</u></b> )
P0302	Cylinder No.2 misfire detected	ON	1	(See <b><u>DTC P0301, P0302, P0303, P0304, P0305, P0306, P0316 [MZI-3.5].</u></b> )
P0303	Cylinder No.3 misfire detected	ON	1	(See <b><u>DTC P0301, P0302, P0303, P0304, P0305, P0306, P0316 [MZI-3.5].</u></b> )
P0304	Cylinder No.4 misfire detected	ON	1	(See <b><u>DTC P0301, P0302, P0303, P0304, P0305, P0306, P0316 [MZI-3.5].</u></b> )
P0305	Cylinder No.5 misfire detected	ON	1	(See <b><u>DTC P0301, P0302, P0303, P0304, P0305, P0306, P0316 [MZI-3.5].</u></b> )
P0306	Cylinder No.6 misfire detected	ON	1	(See <b><u>DTC P0301, P0302, P0303, P0304, P0305, P0306, P0316 [MZI-3.5].</u></b> )
P0315	CKP system variation not learned	ON	2	(See <b><u>DTC P0315 [MZI-3.5].</u></b> )
P0316	Misfire detected on startup (first 1000 revolutions)	OFF	1	(See <b><u>DTC P0301, P0302, P0303, P0304, P0305, P0306, P0316 [MZI-3.5].</u></b> )
P0320	Ignition/distributor engine speed input circuit	ON	2	(See <b><u>DTC P0320 [MZI-3.5].</u></b> )
P0325	KS circuit (RH)	OFF	1	(See <b><u>DTC P0325 [MZI-3.5].</u></b> )
P0330	KS circuit (LH)	OFF	1	(See <b><u>DTC P0330 [MZI-3.5].</u></b> )
P0340	CMP sensor (RH) circuit	ON	2	(See <b><u>DTC P0340 [MZI-3.5].</u></b> )
P0344	CMP sensor (RH) circuit intermittent	ON	2	(See <b><u>DTC P0344 [MZI-3.5].</u></b> )
P0345	CMP sensor (LH) circuit	ON	2	(See <b><u>DTC P0345 [MZI-3.5].</u></b> )
P0349	CMP sensor (LH) circuit intermittent	ON	2	(See <b><u>DTC P0349 [MZI-3.5].</u></b> )

## 2007 Mazda CX-9 Grand Touring

2007 ENGINE PERFORMANCE On-Board Diagnostic (MZI-3.5) - CX-9

P0351	Ignition coil No.1 primary/secondary circuit	ON	2	(See <u>DTC P0351, 0352, 0353, 0354, 0355, 0356 [MZI-3.5].</u> )
P0352	Ignition coil No.2 primary/secondary circuit	ON	2	(See <u>DTC P0351, 0352, 0353, 0354, 0355, 0356 [MZI-3.5].</u> )
P0353	Ignition coil No.3 primary/secondary circuit	ON	2	(See <u>DTC P0351, 0352, 0353, 0354, 0355, 0356 [MZI-3.5].</u> )
P0354	Ignition coil No.4 primary/secondary circuit	ON	2	(See <u>DTC P0351, 0352, 0353, 0354, 0355, 0356 [MZI-3.5].</u> )
P0355	Ignition coil No.5 primary/secondary circuit	ON	2	(See <u>DTC P0351, 0352, 0353, 0354, 0355, 0356 [MZI-3.5].</u> )
P0356	Ignition coil No.6 primary/secondary circuit	ON	2	(See <u>DTC P0351, 0352, 0353, 0354, 0355, 0356 [MZI-3.5].</u> )
P0420	Catalyst system efficiency below threshold (RH)	ON	2	(See <u>DTC P0420, P0430 [MZI-3.5].</u> )
P0430	Catalyst system efficiency below threshold (LH)	ON	2	(See <u>DTC P0420, P0430 [MZI-3.5].</u> )
P0442	Evaporative emission system leak detected (small leak)	ON	2	(See <u>DTC P0442, P0456 [MZI-3.5].</u> )
P0443	Purge solenoid valve circuit	ON	2	(See <u>DTC P0443 [MZI-3.5].</u> )
P0446	CV solenoid valve control circuit	ON	2	(See <u>DTC P0446 [MZI-3.5].</u> )
P0451	Fuel tank pressure sensor range/performance	ON	2	(See <u>DTC P0451 [MZI-3.5].</u> )
P0452	Fuel tank pressure sensor low input	ON	2	(See <u>DTC P0452 [MZI-3.5].</u> )
P0453	Fuel tank pressure sensor high input	ON	2	(See <u>DTC P0453 [MZI-3.5].</u> )
P0454	Fuel tank pressure sensor intermittent	ON	2	(See <u>DTC P0454 [MZI-3.5].</u> )
P0455	Evaporative emission system leak detected (gross leak/no flow)	ON	2	(See <u>DTC P0455 [MZI-3.5].</u> )
P0456	Evaporative emission system leak detected (very small leak)	ON	1	(See <u>DTC P0442, P0456 [MZI-3.5].</u> )
P0457	Evaporative emission system leak detected (fuel cap loose/off).	OFF <sup>(1)</sup>	1	(See <u>DTC P0457 [MZI-3.5].</u> )
P0460	Fuel level sensor circuit	ON	2	(See <u>DTC P0460 [MZI-3.5].</u> )
P0461	Fuel gauge sender unit range/performance problem	ON	2	(See <u>DTC P0461 [MZI-3.5].</u> )
P0462	Fuel gauge sender unit circuit low input	ON	2	(See <u>DTC P0462 [MZI-3.5].</u> )
P0463	Fuel gauge sender unit circuit high input	ON	2	(See <u>DTC P0463 [MZI-3.5].</u> )
P0480	Fan control circuit	OFF	1	(See <u>DTC P0480 [MZI-3.5].</u> )
P0505	Idle speed control system problem	OFF	1	(See <u>DTC P0505 [MZI-3.5].</u> )

## 2007 Mazda CX-9 Grand Touring

2007 ENGINE PERFORMANCE On-Board Diagnostic (MZI-3.5) - CX-9

P0506	IAC system RPM lower than expected	ON	2	(See <b><u>DTC P0506 [MZI-3.5].</u></b> )
P0507	IAC system RPM higher than expected	ON	2	(See <b><u>DTC P0507 [MZI-3.5].</u></b> )
P050E	Cold start engine exhaust temperature out of range	ON	2	(See <b><u>DTC P050E [MZI-3.5].</u></b> )
P053A	PCV valve heater control circuit/open	OFF	1	(See <b><u>DTC P053A [MZI-3.5].</u></b> )
P0579	Cruise control multi-function input circuit range/performance	OFF	1	(See <b><u>DTC P0579 [MZI-3.5].</u></b> )
P0581	Cruise control multi-function input circuit high	OFF	1	(See <b><u>DTC P0581 [MZI-3.5].</u></b> )
P0600	Serial communication link	OFF <sup>(2)</sup>	1	(See <b><u>DTC P0600 [MZI-3.5].</u></b> )
P0602	PCM programming error	ON	2	(See <b><u>DTC P0602 [MZI-3.5].</u></b> )
P0603	PCM keep alive memory (KAM) error	ON	2	(See <b><u>DTC P0603 [MZI-3.5].</u></b> )
P0604	Internal control module random access memory (RAM) error	ON	2	(See <b><u>DTC P0604 [MZI-3.5].</u></b> )
P0605	PCM read only memory (ROM) error	ON	2	(See <b><u>DTC P0605 [MZI-3.5].</u></b> )
P0606	ECM/PCM processor	ON	2	(See <b><u>DTC P0606 [MZI-3.5].</u></b> )
P0607	Control module performance	ON	2	(See <b><u>DTC P0607 [MZI-3.5].</u></b> )
P060A	Internal control module monitoring processor performance	OFF <sup>(2)</sup>	1	(See <b><u>DTC P060A, P060C, P061D [MZI-3.5].</u></b> )
P060B	Internal control module A/D processing performance	ON <sup>(2)</sup>	2	(See <b><u>DTC P060B [MZI-3.5].</u></b> )
P060C	Internal control module main processor performance	ON <sup>(2)</sup>	2	(See <b><u>DTC P060A, P060C, P061D [MZI-3.5].</u></b> )
P0610	Control module vehicle options error	ON	2	(See <b><u>DTC P0610 [MZI-3.5].</u></b> )
P061B	Internal control module torque calculation performance	ON <sup>(2)</sup>	2	(See <b><u>DTC P061B [MZI-3.5].</u></b> )
P061C	Internal control module engine RPM performance	ON <sup>(2)</sup>	2	(See <b><u>DTC P061C [MZI-3.5].</u></b> )
P061D	Internal control module engine air mass performance	ON <sup>(2)</sup>	2	(See <b><u>DTC P060A, P060C, P061D [MZI-3.5].</u></b> )
P061F	Internal control module throttle actuator controller performance	ON <sup>(2)</sup>	2	(See <b><u>DTC P061F [MZI-3.5].</u></b> )
P0620	Generator control circuit	OFF	1	(See <b><u>DTC P0620 [MZI-3.5].</u></b> )
P0625	Generator field terminal circuit low	OFF	1	(See <b><u>DTC P0625 [MZI-3.5].</u></b> )
P0626	Generator field terminal circuit high	OFF	1	(See <b><u>DTC P0626 [MZI-3.5].</u></b> )
P0642	Sensor reference voltage circuit low	ON	2	(See <b><u>DTC P0642 [MZI-3.5].</u></b> )
P0643	Sensor reference voltage circuit high	ON	2	(See <b><u>DTC P0643 [MZI-3.5].</u></b> )
P0645	A/C relay control circuit	OFF	1	(See <b><u>DTC P0645 [MZI-3.5].</u></b> )
P0685	ECM/PCM power relay control circuit/open	OFF	1	(See <b><u>DTC P0685 [MZI-3.5].</u></b> )
P0689	ECM/PCM power relay sense circuit low	OFF	1	(See <b><u>DTC P0689 [MZI-3.5].</u></b> )

## 2007 Mazda CX-9 Grand Touring

2007 ENGINE PERFORMANCE On-Board Diagnostic (MZI-3.5) - CX-9

P0690	ECM/PCM power relay sense circuit high	OFF	1	(See <b><u>DTC P0690 [MZI-3.5].</u></b> )
P1000	OBD II systems readiness test not complete	OFF	1	(See <b><u>DTC P1000 [MZI-3.5].</u></b> )
P1001	KOER not able to complete, KOER aborted	OFF	1	(See <b><u>DTC P1001 [MZI-3.5].</u></b> )
P1101	MAF sensor out of self-test range	OFF	1	(See <b><u>DTC P1101 [MZI-3.5].</u></b> )
P1127	Exhaust temperature out of range, HO2S tests not completed	OFF	1	(See <b><u>DTC P1127 [MZI-3.5].</u></b> )
P115E	Throttle actuator control throttle body air flow trim at max limit	OFF	1	(See <b><u>DTC P115E [MZI-3.5].</u></b> )
P1260	Theft detected, vehicle immobilized	OFF	1	(See <b><u>DTC P1260 [MZI-3.5].</u></b> )
P1285	Cylinder head over temperature condition	OFF	1	(See <b><u>DTC P1285, P1299 [MZI-3.5].</u></b> )
P1288	CHT sensor out of self-test range	OFF	1	(See <b><u>DTC P1288 [MZI-3.5].</u></b> )
P1289	CHT sensor circuit high input	ON	2	(See <b><u>DTC P1289 [MZI-3.5].</u></b> )
P1290	CHT sensor circuit low input	ON	2	(See <b><u>DTC P1290 [MZI-3.5].</u></b> )
P1299	Cylinder head over temperature protection active	ON	1	(See <b><u>DTC P1285, P1299 [MZI-3.5].</u></b> )
P1336	CKP/CMP sensor range/performance	ON	2	(See <b><u>DTC P1336 [MZI-3.5].</u></b> )
P1397	System voltage out of self-test range	OFF	1	(See <b><u>DTC P1397 [MZI-3.5].</u></b> )
P1450	Unable to bleed up fuel tank vacuum	ON	2	(See <b><u>DTC P1450 [MZI-3.5].</u></b> )
P145E	PCV heater control circuit	OFF	1	(See <b><u>DTC P145E [MZI-3.5].</u></b> )
P1464	A/C demand out of self-test range	OFF	1	(See <b><u>DTC P1464 [MZI-3.5].</u></b> )
P1500	Vehicle speed signal	OFF	1	(See <b><u>DTC P1500 [MZI-3.5].</u></b> )
P1501	Vehicle speed sensor (VSS) out of self-test range	OFF	1	(See <b><u>DTC P1501 [MZI-3.5].</u></b> )
P1633	Keep alive power voltage too low	ON	1	(See <b><u>DTC P1633 [MZI-3.5].</u></b> )
P1635	Tire/axle out of acceptable range	OFF	1	(See <b><u>DTC P1635 [MZI-3.5].</u></b> )
P1639	Vehicle ID block corrupted, not programmed	ON	2	(See <b><u>DTC P1639 [MZI-3.5].</u></b> )
P1650	PSP switch out of self-test range	OFF	1	(See <b><u>DTC P1650 [MZI-3.5].</u></b> )
P1674	Control module software corrupted	OFF <sup>(2)</sup>	1	(See <b><u>DTC P1674 [MZI-3.5].</u></b> )
P1703	Brake switch out of self-test range	OFF	1	(See <b><u>DTC P1703 [MZI-3.5].</u></b> )
P2100	Throttle actuator circuit open	OFF <sup>(2)</sup>	1	(See <b><u>DTC P2100 [MZI-3.5].</u></b> )
P2101	Throttle actuator circuit range/performance	ON <sup>(2)</sup>	2	(See <b><u>DTC P2101 [MZI-3.5].</u></b> )
P2104	Throttle actuator control system - forced idle	ON <sup>(2)</sup>	2	(See <b><u>DTC P2104, P2105, P2110 [MZI-3.5].</u></b> )
P2105	Throttle actuator control system - forced engine shutdown	OFF <sup>(2)</sup>	1	(See <b><u>DTC P2104, P2105, P2110 [MZI-3.5].</u></b> )

## 2007 Mazda CX-9 Grand Touring

2007 ENGINE PERFORMANCE On-Board Diagnostic (MZI-3.5) - CX-9

P2107	Throttle actuator control module processor	ON <sup>(2)</sup>	2	(See <b><u>DTC P2107 [MZI-3.5].</u></b> )
P2110	Throttle actuator control system - forced limited RPM	ON <sup>(2)</sup>	2	(See <b><u>DTC P2104, P2105, P2110 [MZI-3.5].</u></b> )
P2111	Throttle actuator control system - stuck open	ON <sup>(2)</sup>	2	(See <b><u>DTC P2111 [MZI-3.5].</u></b> )
P2112	Throttle actuator control system - stuck closed	ON <sup>(2)</sup>	2	(See <b><u>DTC P2112 [MZI-3.5].</u></b> )
P2121	APP sensor No.1 circuit range/performance	OFF <sup>(2)</sup>	1	(See <b><u>DTC P2121, P2126, P2131. [MZI-3.5].</u></b> )
P2122	APP sensor No.1 circuit low input	OFF <sup>(2)</sup>	1	(See <b><u>DTC P2122 [MZI-3.5].</u></b> )
P2123	APP sensor No.1 circuit high input	OFF <sup>(2)</sup>	1	(See <b><u>DTC P2123 [MZI-3.5].</u></b> )
P2126	APP sensor No.2 circuit range/performance	OFF <sup>(2)</sup>	1	(See <b><u>DTC P2121, P2126, P2131 [MZI-3.5].</u></b> )
P2127	APP sensor No.2 circuit low input	OFF <sup>(2)</sup>	1	(See <b><u>DTC P2127 [MZI-3.5].</u></b> )
P2128	APP sensor No.2 circuit high input	OFF <sup>(2)</sup>	1	(See <b><u>DTC P2128 [MZI-3.5].</u></b> )
P2131	APP sensor No.3 circuit range/performance	OFF <sup>(2)</sup>	1	(See <b><u>DTC P2121, P2126, P2131 [MZI-3.5].</u></b> )
P2132	APP sensor No.3 circuit low input	OFF <sup>(2)</sup>	1	(See <b><u>DTC P2132 [MZI-3.5].</u></b> )
P2133	APP sensor No.3 circuit high input	OFF <sup>(2)</sup>	1	(See <b><u>DTC P2133 [MZI-3.5].</u></b> )
P2135	TP sensor No. 1/No.2 voltage correlation	ON <sup>(2)</sup>	2	(See <b><u>DTC P2135 [MZI-3.5].</u></b> )
P2195	Front HO2S (RH) signal stuck lean	ON	2	(See <b><u>DTC P2195, P2197 [MZI-3.5].</u></b> )
P2196	Front HO2S (RH) signal stuck rich	ON	2	(See <b><u>DTC P2196, P2198 [MZI-3.5].</u></b> )
P2197	Front HO2S (LH) signal stuck lean	ON	2	(See <b><u>DTC P2195, P2197 [MZI-3.5].</u></b> )
P2198	Front HO2S (LH) signal stuck rich	ON	2	(See <b><u>DTC P2196, P2198 [MZI-3.5].</u></b> )
P2270	Rear HO2S (RH) signal stuck lean	ON	2	(See <b><u>DTC P2270, P2272 [MZI-3.5].</u></b> )
P2271	Rear HO2S (RH) signal stuck rich	ON	2	(See <b><u>DTC P2271, P2273 [MZI-3.5].</u></b> )
P2272	Rear HO2S (LH) signal stuck lean	ON	2	(See <b><u>DTC P2270, P2272 [MZI-3.5].</u></b> )
P2273	Rear HO2S (LH) signal stuck rich	ON	2	(See <b><u>DTC P2271, P2273 [MZI-3.5].</u></b> )
P260F	Evaporative emission system monitoring processor performance	ON	2	(See <b><u>DTC P260F [MZI-3.5].</u></b> )
U0101	Communication error to TCM	(see <b>PROCEDURES FOR DETERMINING</b>		
U0129	Communication error to DSC/RSC HU/CM			

## 2007 Mazda CX-9 Grand Touring

2007 ENGINE PERFORMANCE On-Board Diagnostic (MZI-3.5) - CX-9

U0155	Communication error to instrument cluster	<b><u>THE LOCATION OF A MALFUNCTION [MULTIPLEX COMMUNICATION SYSTEM] .)</u></b>
U0300 <sup>(2)</sup>	Internal control module software incompatibility	
<p>(1) The fuel cap warning light illuminates.</p> <p>(2) The electronic throttle control (ETC) warning light illuminates.</p>		

### DTC B1342 [MZI-3.5]

#### DTC B1342 DETECTION CONDITION AND POSSIBLE CAUSE

DTC B1342	PCM malfunction
<b>DETECTION CONDITION</b>	<ul style="list-style-type: none"> <li>Malfunction in the PCM internal circuit.</li> </ul>
<b>POSSIBLE CAUSE</b>	<ul style="list-style-type: none"> <li>PCM EEPROM malfunction</li> <li>PCM parameter reset has not been completed</li> </ul>

#### DIAGNOSTIC PROCEDURE

#### DTC B1342 DIAGNOSTIC PROCEDURE

STEP	INSPECTION		ACTION
1	<p><b>VERIFY CURRENT STATUS OF MALFUNCTION</b></p> <ul style="list-style-type: none"> <li>Clear the DTC from the PCM memory using the M-MDS.</li> <li>Perform the PCM parameter reset using the M-MDS.</li> </ul> <p>(see <b><u>IMMOBILIZER SYSTEM COMPONENT REPLACEMENT/KEY ADDITION AND CLEARING [ADVANCED KEYLESS SYSTEM] .)</u></b> (See <b><u>IMMOBILIZER SYSTEM COMPONENT REPLACEMENT/KEY ADDITION AND CLEARING [KEYLESS ENTRY SYSTEM] .)</u></b>)</p> <ul style="list-style-type: none"> <li>Is same DTC present?</li> </ul>	Yes	Replace the PCM, then go to the next step. (see <b><u>PCM REMOVAL/INSTALLATION [MZI-3.5] .)</u></b> )
		No	Go to the next step.
2	<b>VERIFY AFTER REPAIR PROCEDURE</b>	Yes	Go to the applicable DTC inspection. (See <b><u>DTC TABLE [MZI-3.5].)</u></b> )



## 2007 Mazda CX-9 Grand Touring

2007 ENGINE PERFORMANCE On-Board Diagnostic (MZI-3.5) - CX-9

<ul style="list-style-type: none"><li>• Perform the "AFTER REPAIR PROCEDURE".</li></ul> <p>(See <b><u>AFTER REPAIR PROCEDURE [MZI-3.5]</u></b>.)</p> <ul style="list-style-type: none"><li>• Are any DTC present?</li></ul>	No	Troubleshooting completed.
---	----	----------------------------

### DTC P0010 [MZI-3.5]

#### DTC P0010 DETECTION CONDITION AND POSSIBLE CAUSE

<b>DTC P0010</b>	<b>CMP actuator circuit open (RH)</b>
<b>DETECTION CONDITION</b>	<ul style="list-style-type: none"><li>• The PCM monitors the OCV (RH) circuit to the PCM for high and low voltage. T test fails if the voltage exceeds or falls below a calibrated limit for a calibrated amount of time.</li></ul>
<b>POSSIBLE CAUSE</b>	<ul style="list-style-type: none"><li>• OCV (RH) malfunction</li><li>• Connector or terminal malfunction</li><li>• Open circuit between OCV (RH) terminal A and main relay No.1 terminal D</li><li>• Open circuit between OCV (RH) terminal B and PCM terminal 2BP</li><li>• Short to ground circuit between OCV (RH) terminal B and PCM terminal 2BP</li><li>• Short to power supply between OCV (RH) terminal B and PCM terminal 2BP</li></ul>

## 2007 Mazda CX-9 Grand Touring

2007 ENGINE PERFORMANCE On-Board Diagnostic (MZI-3.5) - CX-9

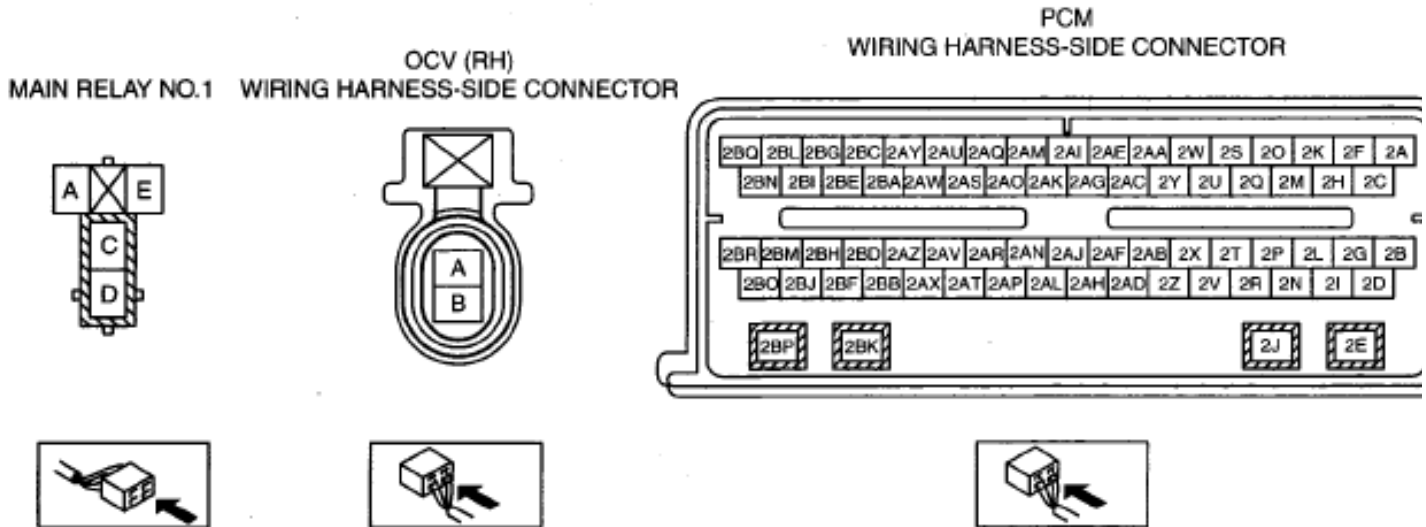
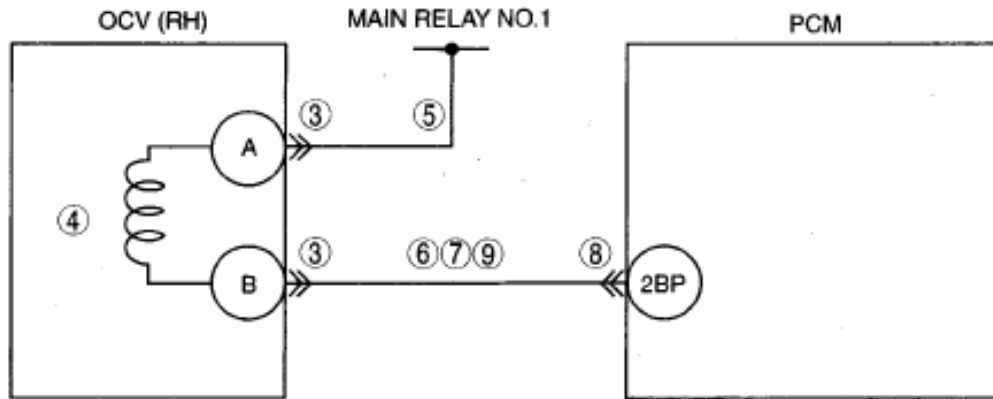

### DIAGNOSTIC PROCEDURE

#### DTC P0010 DIAGNOSTIC PROCEDURE

STEP	INSPECTION		ACTION
1	<b>VERIFY FREEZE FRAME DATA HAS BEEN RECORDED</b>	Yes	Go to the next step.
		No	Record FREEZE FRAME DATA on the repair order, then go to the next step.
2	<b>VERIFY RELATED REPAIR INFORMATION AVAILABILITY</b>	Yes	Perform repair or diagnosis according to the available Service Bulletins.
			<ul style="list-style-type: none"> <li>If the vehicle is not repaired, go to the next step.</li> </ul>

## 2007 Mazda CX-9 Grand Touring

2007 ENGINE PERFORMANCE On-Board Diagnostic (MZI-3.5) - CX-9

	available?	No	Go to the next step.
3	<b>INSPECT OCV (RH) CONNECTOR FOR POOR CONNECTION</b> <ul style="list-style-type: none"> <li>• Turn the ignition switch off.</li> <li>• Disconnect the OCV (RH) connector.</li> <li>• Inspect for poor connection (such as damaged/pulled-out pins, corrosion).</li> <li>• Are there any malfunction?</li> </ul>	Yes	Repair or replace suspected part, then go to Step 10.
		No	Go to the next step.
4	<b>INSPECT OCV (RH)</b> <ul style="list-style-type: none"> <li>• Inspect the OCV (RH).</li> </ul> <p>(see <b><u>OIL CONTROL VALVE (OCV) INSPECTION [MZI-3.5].</u></b>)</p> <ul style="list-style-type: none"> <li>• Is there any malfunction?</li> </ul>	Yes	Replace the OCV (RH), then go to Step 10. (see <b><u>OIL CONTROL VALVE (OCV) REMOVAL/INSTALLATION [MZI-3.5].</u></b> )
		No	Go to the next step.
5	<b>INSPECT OCV (RH) CIRCUIT FOR OPEN CIRCUIT</b> <ul style="list-style-type: none"> <li>• Turn the ignition switch to the ON position (Engine off).</li> <li>• Measure the voltage between the OCV (RH) connector terminal A and body ground.</li> <li>• Is the voltage <b>B+</b> ?</li> </ul>	Yes	Go to the next step.
		No	Repair or replace suspected part, then go to Step 10.
6	<b>INSPECT OCV (RH) CIRCUIT FOR SHORT TO POWER SUPPLY</b> <ul style="list-style-type: none"> <li>• Turn the ignition switch off.</li> <li>• Disconnect the PCM connector.</li> <li>• Turn the ignition switch to the ON position (Engine off).</li> <li>• Measure the voltage between the OCV (RH) connector terminal B (wiring harness-side) and body ground.</li> <li>• Is the voltage <b>B+</b> ?</li> </ul>	Yes	Repair or replace suspected part, then go to Step 10.
		No	Go to the next step.
7	<b>INSPECT OCV (RH) CIRCUIT FOR SHORT TO GROUND</b>	Yes	Repair or replace suspected part, then go to Step 10.

## 2007 Mazda CX-9 Grand Touring

2007 ENGINE PERFORMANCE On-Board Diagnostic (MZI-3.5) - CX-9

	<ul style="list-style-type: none"> <li>• Turn the ignition switch off.</li> <li>• Inspect for continuity between OCV (RH) terminal B (wiring harness-side) and body ground.</li> <li>• Is there continuity?</li> </ul>	No	Go to the next step.
8	<b>INSPECT PCM CONNECTOR FOR POOR CONNECTION</b> <ul style="list-style-type: none"> <li>• Disconnect the PCM connector.</li> <li>• Inspect for poor connection (such as damaged/pulled-out pins, corrosion).</li> <li>• Is there any malfunction?</li> </ul>	Yes	Repair or replace suspected part, then go to Step 10.
		No	Go to the next step.
9	<b>INSPECT OCV (RH) CIRCUIT FOR OPEN CIRCUIT</b> <ul style="list-style-type: none"> <li>• Turn the ignition switch off.</li> <li>• Measure the resistance between the OCV (RH) connector terminal B (wiring harness-side) and PCM terminal 2BP (wiring harness-side).</li> <li>• Is there continuity?</li> </ul>	Yes	Go to the next step.
		No	Repair or replace suspected part, then go to the next step.
10	<b>VERIFY TROUBLESHOOTING OF DTC P0010 HAS BEEN COMPLETED</b> <ul style="list-style-type: none"> <li>• Verify that all disconnected connectors reconnected.</li> <li>• Turn the ignition switch to the ON position (Engine off).</li> <li>• Clear the DTC from the PCM memory using the M-MDS.</li> <li>• Start the engine and run it at idle.</li> <li>• Retrieve DTCs using the M-MDS.</li> <li>• Is the PENDING CODE for this DTC present?</li> </ul>	Yes	Replace the PCM, then go to the next step. (see <b>PCM REMOVAL/INSTALLATION [MZI-3.5]</b> .)
		No	Go to the next step.
11	<b>VERIFY AFTER REPAIR PROCEDURE</b> <ul style="list-style-type: none"> <li>• Perform the "AFTER REPAIR PROCEDURE".</li> </ul>	Yes	Go to the applicable DTC inspection. (See <b>DTC TABLE [MZI-3.5]</b> .)

## 2007 Mazda CX-9 Grand Touring

2007 ENGINE PERFORMANCE On-Board Diagnostic (MZI-3.5) - CX-9

(See <b><u>AFTER REPAIR PROCEDURE [MZI-3.5].</u></b> )  • Are any DTC present?	No	Troubleshooting completed.
--	----	----------------------------

### DTC P0011 [MZI-3.5]

#### DTC P0011 DETECTION CONDITION AND POSSIBLE CAUSE

<b>DTC P0011</b>	<b>CMP timing over-advanced (RH)</b>
<b>DETECTION CONDITION</b>	<ul style="list-style-type: none"> <li>• The PCM monitors the variable valve timing position for an over-advanced camshaft timing. The test fails when the camshaft timing exceeds a maximum calibrated value or remains in an advanced position.</li> </ul>
<b>POSSIBLE CAUSE</b>	<ul style="list-style-type: none"> <li>• OCV (RH) malfunction</li> <li>• Spool valve in OCV (RH) is stuck in advanced position</li> <li>• Improper valve timing due to timing chain slippage</li> </ul>

#### DIAGNOSTIC PROCEDURE

##### DTC P0011 DIAGNOSTIC PROCEDURE

STEP	INSPECTION		ACTION
1	<b>VERIFY FREEZE FRAME DATA HAS BEEN RECORDED</b>  <ul style="list-style-type: none"> <li>• Has FREEZE FRAME DATA been recorded?</li> </ul>	Yes	Go to the next step.
		No	Record FREEZE FRAME DATA on the repair order, then go to the next step.
2	<b>VERIFY RELATED REPAIR INFORMATION AVAILABILITY</b>  <ul style="list-style-type: none"> <li>• Verify related Service Bulletins and/or on-line repair information availability.</li> <li>• Is any related Service Bulletins available?</li> </ul>	Yes	Perform repair or diagnosis according to the available Service Bulletins.  <ul style="list-style-type: none"> <li>• If the vehicle is not repaired, go to the next step.</li> </ul>
		No	Go to the next step.
3	<b>VERIFY TIMING CHAIN INSTALLATION</b>  <ul style="list-style-type: none"> <li>• Stop the engine.</li> <li>• Remove the front cover.</li> <li>• Is the camshaft timing mark at the correct point?</li> </ul> <p>(see <b><u>TIMING CHAIN REMOVAL/INSTALLATION</u></b>)</p>	Yes	Go to the next step.
		No	Reinstall the timing chain, then go to Step 5.

## 2007 Mazda CX-9 Grand Touring

2007 ENGINE PERFORMANCE On-Board Diagnostic (MZI-3.5) - CX-9

<u>[MZI-3.5] .)</u>			
4	<b>INSPECT OCV (RH)</b> <ul style="list-style-type: none"> <li>• Inspect the OCV (RH).</li> </ul> <p>(see <b><u>OIL CONTROL VALVE (OCV) INSPECTION [MZI-3.5].</u></b>)</p> <ul style="list-style-type: none"> <li>• Is there any malfunction?</li> </ul>	Yes	Replace the OCV (RH), then go to the next step. (see <b><u>OIL CONTROL VALVE (OCV) REMOVAL/INSTALLATION [MZI-3.5].</u></b> )
		No	Go to the next step.
5	<b>VERIFY TROUBLESHOOTING OF DTC P0011 HAS BEEN COMPLETED</b> <ul style="list-style-type: none"> <li>• Make sure to reconnect all disconnected connectors.</li> <li>• Clear the DTC from the PCM memory using the M-MDS.</li> <li>• Turn the ignition switch off.</li> <li>• Start the engine and warm it up completely.</li> <li>• Is the same DTC present?</li> </ul>	Yes	Replace the PCM, then go to the next step. (see <b><u>PCM REMOVAL/INSTALLATION [MZI-3.5] .)</u></b> )
		No	Go to the next step.
6	<b>VERIFY AFTER REPAIR PROCEDURE</b> <ul style="list-style-type: none"> <li>• Perform the "AFTER REPAIR PROCEDURE".</li> </ul> <p>(See <b><u>AFTER REPAIR PROCEDURE [MZI-3.5].</u></b>)</p> <ul style="list-style-type: none"> <li>• Are any DTCs present?</li> </ul>	Yes	Go to the applicable DTC inspection. (See <b><u>DTC TABLE [MZI-3.5].</u></b> )
		No	Troubleshooting completed.

### DTC P0012 [MZI-3.5]

#### DTC P0012 DETECTION CONDITION AND POSSIBLE CAUSE

DTC P0012	CMP timing over-retarded (RH)
<b>DETECTION CONDITION</b>	<ul style="list-style-type: none"> <li>• The PCM monitors the variable valve timing position for over-retarded camshaft timing. The test fails when the camshaft timing exceeds a maximum calibrated value or-remains in a retarded position.</li> </ul>
<b>POSSIBLE CAUSE</b>	<ul style="list-style-type: none"> <li>• OCV (RH) malfunction</li> <li>• Low engine oil pressure</li> <li>• Spool valve in the OCV (RH) is stuck in retard position</li> <li>• Improper valve timing due to timing chain slippage</li> </ul>

## 2007 Mazda CX-9 Grand Touring

2007 ENGINE PERFORMANCE On-Board Diagnostic (MZI-3.5) - CX-9

### DIAGNOSTIC PROCEDURE

#### DTC P0012 DIAGNOSTIC PROCEDURE

STEP	INSPECTION	ACTION	
1	<b>VERIFY FREEZE FRAME DATA HAS BEEN RECORDED</b> <ul style="list-style-type: none"> <li>• Has FREEZE FRAME DATA been recorded?</li> </ul>	Yes	Go to the next step.
		No	Record FREEZE FRAME DATA on the repair order, then go to the next step.
2	<b>VERIFY RELATED REPAIR INFORMATION AVAILABILITY</b> <ul style="list-style-type: none"> <li>• Verify related Service Bulletins and/or on-line repair information availability.</li> <li>• Is any related Service Bulletins available?</li> </ul>	Yes	Perform repair or diagnosis according to the available Service Bulletins. <ul style="list-style-type: none"> <li>• If the vehicle is not repaired, go to the next step.</li> </ul>
		No	Go to the next step.
3	<b>VERIFY ENGINE OIL PRESSURE</b> <ul style="list-style-type: none"> <li>• Start the engine.</li> <li>• Does the oil pressure warning light illuminate?</li> </ul>	Yes	Inspect the engine oil pressure, then go to Step 6. (see <b><u>OIL PRESSURE INSPECTION [MZI-3.5]</u></b> )
		No	Go to the next step.
4	<b>VERIFY TIMING CHAIN INSTALLATION</b> <ul style="list-style-type: none"> <li>• Stop the engine.</li> <li>• Remove the front cover.</li> <li>• Is the camshaft timing mark at the correct point?</li> </ul> <p>(see <b><u>TIMING CHAIN REMOVAL/INSTALLATION [MZI-3.5]</u></b> .)</p>	Yes	Go to the next step.
		No	Reinstall the timing chain, then go to Step 6.
5	<b>INSPECT OCV (RH)</b> <ul style="list-style-type: none"> <li>• Inspect the OCV (RH).</li> </ul> <p>(see <b><u>OIL CONTROL VALVE (OCV) INSPECTION [MZI-3.5]</u></b> .)</p> <ul style="list-style-type: none"> <li>• Is there any malfunction?</li> </ul>	Yes	Replace the OCV (RH), then go to the next step.
		No	Go to the next step.
6	<b>VERIFY TROUBLESHOOTING OF DTC P0012 COMPLETED</b> <ul style="list-style-type: none"> <li>• Make sure to reconnect all</li> </ul>	Yes	Replace the PCM, then go to the next step. (see <b><u>PCM REMOVAL/INSTALLATION [MZI-</u></b>

## 2007 Mazda CX-9 Grand Touring

2007 ENGINE PERFORMANCE On-Board Diagnostic (MZI-3.5) - CX-9

	<p>disconnected connectors.</p> <ul style="list-style-type: none"> <li>• Clear the DTC from the PCM memory using the M-MDS.</li> <li>• Turn the ignition switch off.</li> <li>• Start the engine and warm it up completely.</li> <li>• Is the PENDING CODE for this DTC present?</li> </ul>		<b>3.5]</b> .)
		No	Go to the next step.
7	<p><b>VERIFY AFTER REPAIR PROCEDURE</b></p> <ul style="list-style-type: none"> <li>• Perform the "AFTER REPAIR PROCEDURE".</li> </ul> <p>(See <b><u>AFTER REPAIR PROCEDURE [MZI-3.5].</u></b>)</p> <ul style="list-style-type: none"> <li>• Are any DTCs present?</li> </ul>	Yes	Go to the applicable DTC inspection. (See <b><u>DTC TABLE [MZI-3.5].</u></b> )
		No	Troubleshooting completed.

### DTC P0016, P0018 [MZI-3.5]

#### DTC P0016, P0018 (MZI-3.5) DETECTION CONDITION AND POSSIBLE CAUSES

<b>DTC P0016</b>	<b>P0016: CKP-CMP sensor (RH) correlation</b>
<b>DTC P0018</b>	<b>P0018: CKP-CMP sensor (LH) correlation</b>
<b>DETECTION CONDITION</b>	<ul style="list-style-type: none"> <li>• The PCM monitors the variable valve timing position for a misalignment between the camshaft and crankshaft. The test fails when the misalignment is more than 1 tooth.</li> </ul>
<b>POSSIBLE CAUSE</b>	<ul style="list-style-type: none"> <li>• OCV malfunction</li> <li>• Camshaft advanced mechanism binding</li> <li>• Improper valve timing</li> </ul>

#### DIAGNOSTIC PROCEDURE

#### DTC P0016, P0018 (MZI-3.5) DIAGNOSTIC PROCEDURE

STEP	INSPECTION	ACTION	
1	<p><b>VERIFY FREEZE FRAME DATA HAS BEEN RECORDED</b></p> <ul style="list-style-type: none"> <li>• Has FREEZE FRAME DATA been recorded?</li> </ul>	Yes	Go to the next step.
		No	Record the FREEZE FRAME DATA on the repair order, then go to the next step.
2	<p><b>VERIFY RELATED REPAIR INFORMATION AVAILABILITY</b></p>	Yes	Perform repair or diagnosis according to the available Service Bulletins.



## 2007 Mazda CX-9 Grand Touring

2007 ENGINE PERFORMANCE On-Board Diagnostic (MZI-3.5) - CX-9

	<ul style="list-style-type: none"> <li>Verify related Service Bulletins and/or on-line repair information availability.</li> <li>Is any related Service Bulletins available?</li> </ul>		<ul style="list-style-type: none"> <li>If the vehicle is not repaired, go to the next step.</li> </ul>
		No	Go to the next step.
3	<p><b>VERIFY RELATED PENDING AND STORED DTC</b></p> <ul style="list-style-type: none"> <li>Turn the ignition switch off, then to the ON position (Engine off)</li> <li>Verify pending and stored DTCs using M-MDS.</li> <li>Is other DTC present?</li> </ul>	Yes	Go to the appropriate DTC troubleshooting. (See <b><u>DTC TABLE [MZI-3.5].</u></b> )
		No	Go to the next step.
4	<p><b>VERIFY CURRENT INPUT SIGNAL STATUS</b></p> <ul style="list-style-type: none"> <li>Start the engine and warm up completely.</li> <li>Access VT ACT1 (P0016) or VT ACT2 (P0018) PID using the M-MDS.</li> <li>Is PID reading normal? <ul style="list-style-type: none"> <li>-14-46 °</li> </ul> </li> </ul>	Yes	Go to the next step.
		No	Replace the OCV, then go to Step 6. (see <b><u>OIL CONTROL VALVE (OCV) REMOVAL/INSTALLATION [MZI-3.5].</u></b> )
5	<p><b>VERIFY TIMING CHAIN INSTALLATION</b></p> <ul style="list-style-type: none"> <li>Stop the engine.</li> <li>Remove the front cover.</li> <li>Is the camshaft timing mark at the correct point?</li> </ul> <p>(see <b><u>TIMING CHAIN REMOVAL/INSTALLATION [MZI-3.5].</u></b>)</p>	Yes	Go to the next step.
		No	Reinstall the timing chain, then go to the next step.
6	<p><b>VERIFY TROUBLESHOOTING OF DTC P0016, P0018 HAS BEEN COMPLETED</b></p> <ul style="list-style-type: none"> <li>Make sure to reconnect all disconnected connectors.</li> <li>Turn the engine switch to the ON position.</li> <li>Clear the DTC from the PCM</li> </ul>	Yes	Replace the PCM, then go to the next step. (see <b><u>PCM REMOVAL/INSTALLATION [MZI-3.5].</u></b> )

## 2007 Mazda CX-9 Grand Touring

2007 ENGINE PERFORMANCE On-Board Diagnostic (MZI-3.5) - CX-9

	<p>memory using the M-MDS.</p> <ul style="list-style-type: none"> <li>Start the engine.</li> <li>Is the same DTC present?</li> </ul>	No	Go to the next step.
7	<p><b>VERIFY AFTER REPAIR PROCEDURE</b></p> <ul style="list-style-type: none"> <li>Perform the "AFTER REPAIR PROCEDURE".</li> </ul> <p>(See <b><u>AFTER REPAIR PROCEDURE [MZI-3.5].</u></b>)</p> <ul style="list-style-type: none"> <li>Are any DTCs present?</li> </ul>	Yes	Go to the applicable DTC inspection. (See <b><u>DTC TABLE [MZI-3.5].</u></b> )
		No	Troubleshooting completed.

### DTC P0020 [MZI-3.5]

#### DTC P0020 (MZI-3.5) DETECTION CONDITION AND POSSIBLE CAUSES

<b>DTC P0020</b>	<b>CMP actuator circuit open (LH)</b>
<b>DETECTION CONDITION</b>	<ul style="list-style-type: none"> <li>The PCM monitors the OCV (LH) circuit to the PCM for high and low voltage. T test fails if the voltage exceeds or falls below a calibrated limit for a calibrated amount of time.</li> </ul>
<b>POSSIBLE CAUSE</b>	<ul style="list-style-type: none"> <li>OCV (LH) malfunction</li> <li>Connector or terminal malfunction</li> <li>Open circuit between OCV (LH) terminal A and main relay No.1 terminal D</li> <li>Open circuit between OCV (LH) terminal B and PCM terminal 2BK</li> <li>Short to ground circuit between OCV (LH) terminal B and PCM terminal 2BK</li> <li>Short to power supply between OCV (LH) terminal B and PCM terminal 2BK</li> </ul>

# 2007 Mazda CX-9 Grand Touring

2007 ENGINE PERFORMANCE On-Board Diagnostic (MZI-3.5) - CX-9

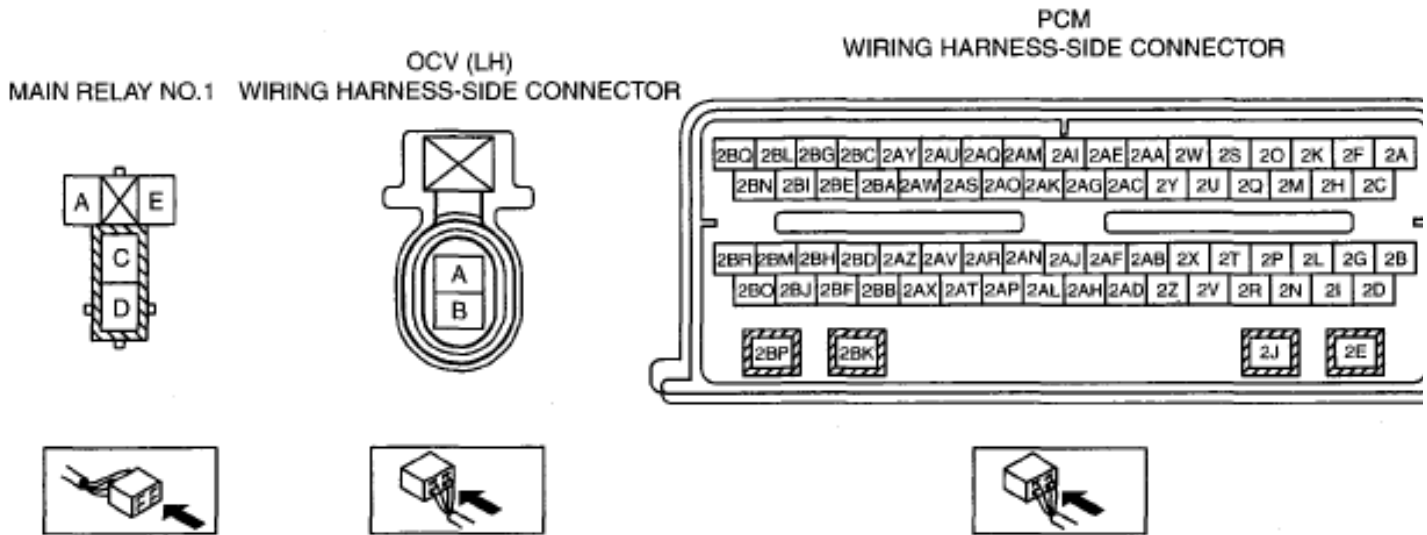
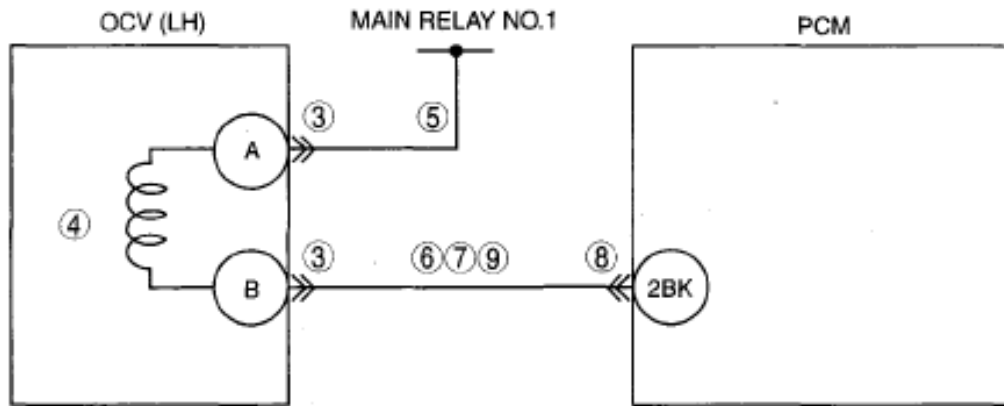

## DIAGNOSTIC PROCEDURE

### DTC P0020 (MZI-3.5) DIAGNOSTIC PROCEDURE

STEP	INSPECTION		ACTION
1	<b>VERIFY FREEZE FRAME DATA HAS BEEN RECORDED</b>  • Has FREEZE FRAME DATA been recorded?	Yes	Go to the next step.
		No	Record FREEZE FRAME DATA on the repair order, then go to the next step.
2	<b>VERIFY RELATED REPAIR INFORMATION AVAILABILITY</b>  • Verify related Service Bulletins and/or on-line repair information availability.	Yes	Perform repair or diagnosis according to the available Service Bulletins.  • If the vehicle is not repaired, go to the next step.

## 2007 Mazda CX-9 Grand Touring

2007 ENGINE PERFORMANCE On-Board Diagnostic (MZI-3.5) - CX-9

	<ul style="list-style-type: none"> <li>• Is any related Service Bulletins available?</li> </ul>	No	Go to the next step.
3	<b>INSPECT OCV (LH) CONNECTOR FOR POOR CONNECTION</b> <ul style="list-style-type: none"> <li>• Turn the ignition switch off.</li> <li>• Disconnect the OCV (LH) connector.</li> <li>• Inspect for poor connection (such as damaged/pulled-out pins, corrosion).</li> <li>• Are there any malfunction?</li> </ul>	Yes	Repair or replace suspected part, then go to Step 10.
		No	Go to the next step.
4	<b>INSPECT OCV (LH)</b> <ul style="list-style-type: none"> <li>• Inspect the OCV (LH).</li> </ul> <p>(see <b><u>OIL CONTROL VALVE (OCV) INSPECTION [MZI-3.5].</u></b> )</p> <ul style="list-style-type: none"> <li>• Is there any malfunction?</li> </ul>	Yes	Replace the OCV (LH), then go to Step 10. (see <b><u>OIL CONTROL VALVE (OCV) REMOVAL/INSTALLATION [MZI-3.5].</u></b> )
		No	Go to the next step.
5	<b>INSPECT OCV (LH) CIRCUIT FOR OPEN CIRCUIT</b> <ul style="list-style-type: none"> <li>• Turn the ignition switch to the ON position (Engine off).</li> <li>• Measure the voltage between the OCV (LH) connector terminal A (wiring harness-side) and body ground.</li> <li>• Is the voltage B+?</li> </ul>	Yes	Go to the next step.
		No	Repair or replace suspected part, then go to Step 10.
6	<b>INSPECT OCV (LH) CIRCUIT FOR SHORT TO POWER SUPPLY</b> <ul style="list-style-type: none"> <li>• Disconnect the PCM connector.</li> <li>• Turn the ignition switch to the ON position (Engine off).</li> <li>• Measure the voltage between the OCV (LH) connector terminal B and body ground.</li> <li>• Is the voltage B+?</li> </ul>	Yes	Repair or replace suspected part, then go to Step 10.
		No	Go to the next step.
7	<b>INSPECT OCV (LH) CIRCUIT FOR SHORT TO GROUND</b>	Yes	Repair or replace suspected part, then go to Step 10.

## 2007 Mazda CX-9 Grand Touring

2007 ENGINE PERFORMANCE On-Board Diagnostic (MZI-3.5) - CX-9

	<ul style="list-style-type: none"> <li>• Turn the ignition switch to the ON position (Engine off).</li> <li>• Inspect for continuity between OCV (LH) terminal B (wiring harness-side) and body ground.</li> <li>• Is there continuity?</li> </ul>	No	Go to the next step.
8	<b>INSPECT PCM CONNECTOR FOR POOR CONNECTION</b> <ul style="list-style-type: none"> <li>• Disconnect the PCM connector.</li> <li>• Inspect for poor connection (such as damaged/pulled-out pins, corrosion).</li> <li>• Is there any malfunction?</li> </ul>	Yes	Repair or replace suspected part, then go to Step 10.
		No	Go to the next step.
9	<b>INSPECT OCV (LH) CIRCUIT FOR OPEN CIRCUIT</b> <ul style="list-style-type: none"> <li>• Turn the ignition switch off.</li> <li>• Measure the resistance between the OCV (LH) connector terminal B (wiring harness-side) and PCM terminal 2BK (wiring harness-side).</li> <li>• Is there continuity?</li> </ul>	Yes	Go to the next step.
		No	Repair or replace suspected part, Then go to the next step.
10	<b>VERIFY TROUBLESHOOTING OF DTC P0020 HAS BEEN COMPLETED</b> <ul style="list-style-type: none"> <li>• Verify that all disconnected connectors reconnected.</li> <li>• Turn the ignition switch to the ON position (Engine off).</li> <li>• Clear the DTC from the PCM memory using the M-MDS.</li> <li>• Start the engine and run it at idle.</li> <li>• Retrieve DTCs using the M-MDS.</li> <li>• Is the PENDING CODE for this DTC present?</li> </ul>	Yes	Replace the PCM, then go to the next step. (see <b><u>PCM REMOVAL/INSTALLATION [MZI-3.5]</u></b> .)
		No	Go to the next step.
11	<b>VERIFY AFTER REPAIR PROCEDURE</b> <ul style="list-style-type: none"> <li>• Perform the "AFTER REPAIR PROCEDURE".</li> </ul>	Yes	Go to the applicable DTC inspection. (See <b><u>DTC TABLE [MZI-3.5]</u></b> .)

## 2007 Mazda CX-9 Grand Touring

2007 ENGINE PERFORMANCE On-Board Diagnostic (MZI-3.5) - CX-9

(See <b><u>AFTER REPAIR PROCEDURE [MZI-3.5].</u></b> )  • Are any DTC present?	No	Troubleshooting completed.
--	----	----------------------------

### DTC P0021 [MZI-3.5]

#### DTC P0021 (MZI-3.5) DETECTION CONDITION AND POSSIBLE CAUSES

<b>DTC P0021</b>	<b>CMP timing over-advanced (LH)</b>
<b>DETECTION CONDITION</b>	<ul style="list-style-type: none"> <li>The PCM monitors the variable valve timing position for an over-advanced camshaft timing. The test fails when the camshaft timing exceeds a maximum calibrated value or remains in an advanced position.</li> </ul>
<b>POSSIBLE CAUSE</b>	<ul style="list-style-type: none"> <li>OCV (LH) malfunction</li> <li>Spool valve in OCV (LH) is stuck in advanced position</li> <li>Improper valve timing due to timing chain slippage</li> </ul>

#### DIAGNOSTIC PROCEDURE

#### DTC P0021 (MZI-3.5) DIAGNOSTIC PROCEDURE

STEP	INSPECTION		ACTION
1	<b>VERIFY FREEZE FRAME DATA HAS BEEN RECORDED</b>  <ul style="list-style-type: none"> <li>Has FREEZE FRAME DATA been recorded?</li> </ul>	Yes	Go to the next step.
		No	Record FREEZE FRAME DATA on the repair order, then go to the next step.
2	<b>VERIFY RELATED REPAIR INFORMATION AVAILABILITY</b>  <ul style="list-style-type: none"> <li>Verify related Service Bulletins and/or on-line repair information availability.</li> <li>Is any related Service Bulletins available?</li> </ul>	Yes	Perform repair or diagnosis according to the available Service Bulletins.  <ul style="list-style-type: none"> <li>If the vehicle is not repaired, go to the next step.</li> </ul>
		No	Go to the next step.
3	<b>VERIFY TIMING CHAIN INSTALLATION</b>  <ul style="list-style-type: none"> <li>Stop the engine.</li> <li>Remove the front cover.</li> <li>Is the camshaft timing mark at the correct point?</li> </ul> <p>(see <b><u>TIMING CHAIN REMOVAL/INSTALLATION</u></b>)</p>	Yes	Go to the next step.
		No	Reinstall the timing chain, then go to Step 5.

## 2007 Mazda CX-9 Grand Touring

2007 ENGINE PERFORMANCE On-Board Diagnostic (MZI-3.5) - CX-9

<u>[MZI-3.5] .)</u>			
4	<b>INSPECT OCV (LH)</b> <ul style="list-style-type: none"> <li>• Inspect the OCV (LH).</li> </ul> <p>(see <b><u>OIL CONTROL VALVE (OCV) INSPECTION [MZI-3.5].</u></b>)</p> <ul style="list-style-type: none"> <li>• Is there any malfunction?</li> </ul>	Yes	Replace the OCV (LH), then go to the next step. (see <b><u>OIL CONTROL VALVE (OCV) REMOVAL/INSTALLATION [MZI-3.5].</u></b> )
		No	Go to the next step.
5	<b>VERIFY TROUBLESHOOTING OF DTC P0021 HAS BEEN COMPLETED</b> <ul style="list-style-type: none"> <li>• Make sure to reconnect all disconnected connectors.</li> <li>• Clear the DTC from the PCM memory using the M-MDS.</li> <li>• Turn the ignition switch off.</li> <li>• Start the engine and warm it up completely.</li> <li>• Is the same DTC present?</li> </ul>	Yes	Replace the PCM, then go to the next step. (see <b><u>PCM REMOVAL/INSTALLATION [MZI-3.5] .)</u></b> )
		No	Go to the next step.
6	<b>VERIFY AFTER REPAIR PROCEDURE</b> <ul style="list-style-type: none"> <li>• Perform the "AFTER REPAIR PROCEDURE".</li> </ul> <p>(See <b><u>AFTER REPAIR PROCEDURE [MZI-3.5].</u></b>)</p> <ul style="list-style-type: none"> <li>• Are any DTCs present?</li> </ul>	Yes	Go to the applicable DTC inspection. (See <b><u>DTC TABLE [MZI-3.5].</u></b> )
		No	Troubleshooting completed.

### DTC P0022 [MZI-3.5]

#### DTC P0022 (MZI-3.5) DETECTION CONDITION AND POSSIBLE CAUSES

DTC P0022	CMP timing over-retarded (LH)
<b>DETECTION CONDITION</b>	<ul style="list-style-type: none"> <li>• The PCM monitors the variable valve timing position for over-retarded camshaft timing. The test fails when the camshaft timing exceeds a maximum calibrated value or remains in a retarded position.</li> </ul>
<b>POSSIBLE CAUSE</b>	<ul style="list-style-type: none"> <li>• OCV (LH) malfunction</li> <li>• Low engine oil pressure</li> <li>• Spool valve in the OCV (LH) is stuck in retard position</li> <li>• Improper valve timing due to timing chain slippage</li> </ul>

## 2007 Mazda CX-9 Grand Touring

2007 ENGINE PERFORMANCE On-Board Diagnostic (MZI-3.5) - CX-9

### DIAGNOSTIC PROCEDURE

#### DTC P0022 (MZI-3.5) DIAGNOSTIC PROCEDURE

STEP	INSPECTION	ACTION	
1	<b>VERIFY FREEZE FRAME DATA HAS BEEN RECORDED</b> <ul style="list-style-type: none"> <li>• Has FREEZE FRAME DATA been recorded?</li> </ul>	Yes	Go to the next step.
		No	Record FREEZE FRAME DATA on the repair order, then go to the next step.
2	<b>VERIFY RELATED REPAIR INFORMATION AVAILABILITY</b> <ul style="list-style-type: none"> <li>• Verify related Service Bulletins and/or on-line repair information availability.</li> <li>• Is any related Service Bulletins available?</li> </ul>	Yes	Perform repair or diagnosis according to the available Service Bulletins. <ul style="list-style-type: none"> <li>• If the vehicle is not repaired, go to the next step.</li> </ul>
		No	Go to the next step.
3	<b>VERIFY ENGINE OIL PRESSURE</b> <ul style="list-style-type: none"> <li>• Start the engine.</li> <li>• Does the oil pressure warning light illuminate?</li> </ul>	Yes	Inspect the engine oil pressure, then go to Step 6. (see <b><u>OIL PRESSURE INSPECTION [MZI-3.5]</u></b> .)
		No	Go to the next step.
4	<b>VERIFY TIMING CHAIN INSTALLATION</b> <ul style="list-style-type: none"> <li>• Stop the engine.</li> <li>• Remove the front cover.</li> <li>• Is the camshaft timing mark at the correct point?</li> </ul> <p>(see <b><u>TIMING CHAIN REMOVAL/INSTALLATION [MZI-3.5]</u></b> .)</p>	Yes	Go to the next step.
		No	Reinstall the timing chain, then go to Step 6.
5	<b>INSPECT OCV (LH)</b> <ul style="list-style-type: none"> <li>• Inspect the OCV (LH).</li> </ul> <p>(see <b><u>OIL CONTROL VALVE (OCV) INSPECTION [MZI-3.5]</u></b> .)</p> <ul style="list-style-type: none"> <li>• Is there any malfunction?</li> </ul>	Yes	Replace the OCV (LH), then go to the next step.
		No	Go to the next step.
6	<b>VERIFY TROUBLESHOOTING OF DTC P0022 COMPLETED</b> <ul style="list-style-type: none"> <li>• Make sure to reconnect all</li> </ul>	Yes	Replace the PCM, then go to the next step. (see <b><u>PCM REMOVAL/INSTALLATION [MZI-</u></b>



## 2007 Mazda CX-9 Grand Touring

2007 ENGINE PERFORMANCE On-Board Diagnostic (MZI-3.5) - CX-9

	<p>disconnected connectors.</p> <ul style="list-style-type: none"> <li>• Clear the DTC from the PCM memory using the M-MDS.</li> <li>• Turn the ignition switch off.</li> <li>• Start the engine and warm it up completely.</li> <li>• Is the PENDING CODE for this DTC present?</li> </ul>		<b>3.5]</b> .)
		No	Go to the next step.
7	<p><b>VERIFY AFTER REPAIR PROCEDURE</b></p> <ul style="list-style-type: none"> <li>• Perform the "AFTER REPAIR PROCEDURE".</li> </ul> <p>(See <b><u>AFTER REPAIR PROCEDURE [MZI-3.5].</u></b>)</p> <ul style="list-style-type: none"> <li>• Are any DTCs present?</li> </ul>	Yes	Go to the applicable DTC inspection. (See <b><u>DTC TABLE [MZI-3.5].</u></b> )
		No	Troubleshooting completed.

### DTC P0040, P0041 [MZI-3.5]

#### DTC P0040, P0041 (MZI-3.5) DETECTION CONDITION AND POSSIBLE CAUSES

<b>DTC P0040</b>	<b>P0040: Front HO2S (LH/RH) signals swapped</b>
<b>DTC P0041</b>	<b>P0041: Rear HO2S (LH/RH) signals swapped</b>
<b>DETECTION CONDITION</b>	<ul style="list-style-type: none"> <li>• P0040 indicates that during KOER testing, the front HO2S signal(s) response for a fuel shift to the correct engine bank was not indicated.</li> <li>• P0041 indicates that during KOER testing, the rear HO2S signal(s) response for a fuel shift to the correct engine bank was not indicated.</li> </ul>
<b>POSSIBLE CAUSE</b>	<ul style="list-style-type: none"> <li>• Crossed HO2S harness connectors.</li> <li>• Crossed wiring at HO2S harness connectors.</li> <li>• Crossed wiring at PCM harness connector.</li> </ul>

#### DIAGNOSTIC PROCEDURE

#### DTC P0040, P0041 (MZI-3.5) DIAGNOSTIC PROCEDURE

STEP	INSPECTION		ACTION
1	<b>VERIFY FREEZE FRAME DATA HAS BEEN RECORDED</b>	Yes	Go to the next step.
	<ul style="list-style-type: none"> <li>• Has FREEZE FRAME DATA been recorded?</li> </ul>	No	Record FREEZE FRAME DATA on the repair order, then go to the next step.
2	<b>VERIFY RELATED REPAIR</b>	Yes	Perform repair or diagnosis according to

## 2007 Mazda CX-9 Grand Touring

2007 ENGINE PERFORMANCE On-Board Diagnostic (MZI-3.5) - CX-9

	<p><b>INFORMATION AVAILABILITY</b></p> <ul style="list-style-type: none"> <li>• Verify related Service Bulletins and/or on-line repair information availability.</li> <li>• Is any related Service Bulletins available?</li> </ul>		<p>the available Service Bulletins.</p> <ul style="list-style-type: none"> <li>• If the vehicle is not repaired, go to the next step.</li> </ul>
		No	Go to the next step.
3	<p><b>INSPECT HO2S WIRING HARNESS CONNECTORS</b></p> <ul style="list-style-type: none"> <li>• For P0040, visually inspect the vehicle front HO2S wiring harness connector (s) for any indication of crossed wires (Also, stretched or incorrectly mounted wiring harnesses).</li> <li>• For P0041, visually inspect the vehicle rear HO2S wiring harness connector (s) for any indication of crossed wires (Also, stretched or incorrectly mounted wiring harnesses).</li> <li>• Are there crossed connections or wires?</li> </ul>	Yes	Repair if necessary.
		No	Go to the next step.
4	<p><b>VERIFY TROUBLESHOOTING OF DTC P0040, P0041 HAS BEEN COMPLETED</b></p> <ul style="list-style-type: none"> <li>• Verify that all disconnected connectors reconnected.</li> <li>• Turn the ignition switch to the ON position (Engine off).</li> <li>• Clear the DTC from the PCM memory using the M-MDS.</li> <li>• Start the engine and run it at idle.</li> <li>• Retrieve DTCs using the M-MDS.</li> <li>• Is the PENDING CODE for this DTC present?</li> </ul>	Yes	Replace the PCM, then go to the next step. (see <b><u>PCM REMOVAL/INSTALLATION [MZI-3.5]</u></b> .)
		No	Go to the next step.
5	<p><b>VERIFY AFTER REPAIR PROCEDURE</b></p> <ul style="list-style-type: none"> <li>• Perform "AFTER REPAIR PROCEDURE".</li> </ul>	Yes	Go to the applicable DTC inspection. (See <b><u>DTC TABLE [MZI-3.5]</u></b> .)

## 2007 Mazda CX-9 Grand Touring

2007 ENGINE PERFORMANCE On-Board Diagnostic (MZI-3.5) - CX-9

<p>(See <b><u>AFTER REPAIR PROCEDURE [MZI-3.5].</u></b>)</p> <ul style="list-style-type: none"> <li>• Are any DTC present?</li> </ul>	No	Troubleshooting completed.
---	----	----------------------------

### DTC P0053, P0054, P0059, P0060 [MZI-3.5]

#### DTC P0053, P0054, P0059, P0060 (MZI-3.5) DETECTION CONDITION AND POSSIBLE CAUSES

<b>DTC P0053</b>	<b>P0053: Front HO2S (RH) heater resistance</b>
<b>DTC P0054</b>	<b>P0054: Rear HO2S (RH) heater resistance</b>
<b>DTC P0059</b>	<b>P0059: Front HO2S (LH) heater resistance</b>
<b>DTC P0060</b>	<b>P0060: Rear HO2S (LH) heater resistance</b>
<b>DETECTION CONDITION</b>	<ul style="list-style-type: none"> <li>• Heater current requirements too low or high in the heated oxygen sensor (HO2S) control circuit.</li> </ul>
<b>POSSIBLE CAUSE</b>	<ul style="list-style-type: none"> <li>• Open circuit between HO2S terminal C and main relay No.1 terminal E</li> <li>• Short to ground circuit between HO2S terminal A and body ground</li> <li>• HO2S circuits are shorted each other</li> <li>• DTC P0053: Open circuit between front HO2S (RH) terminal A and PCM terminal</li> <li>• DTC P0054: Open circuit between rear HO2S (RH) terminal A and PCM terminal</li> <li>• DTC P0059: Open circuit between front HO2S (LH) terminal A and PCM terminal</li> <li>• DTC P0060: Open circuit between rear HO2S (LH) terminal A and PCM terminal</li> <li>• HO2S heater malfunction</li> </ul>

# 2007 Mazda CX-9 Grand Touring

2007 ENGINE PERFORMANCE On-Board Diagnostic (MZI-3.5) - CX-9

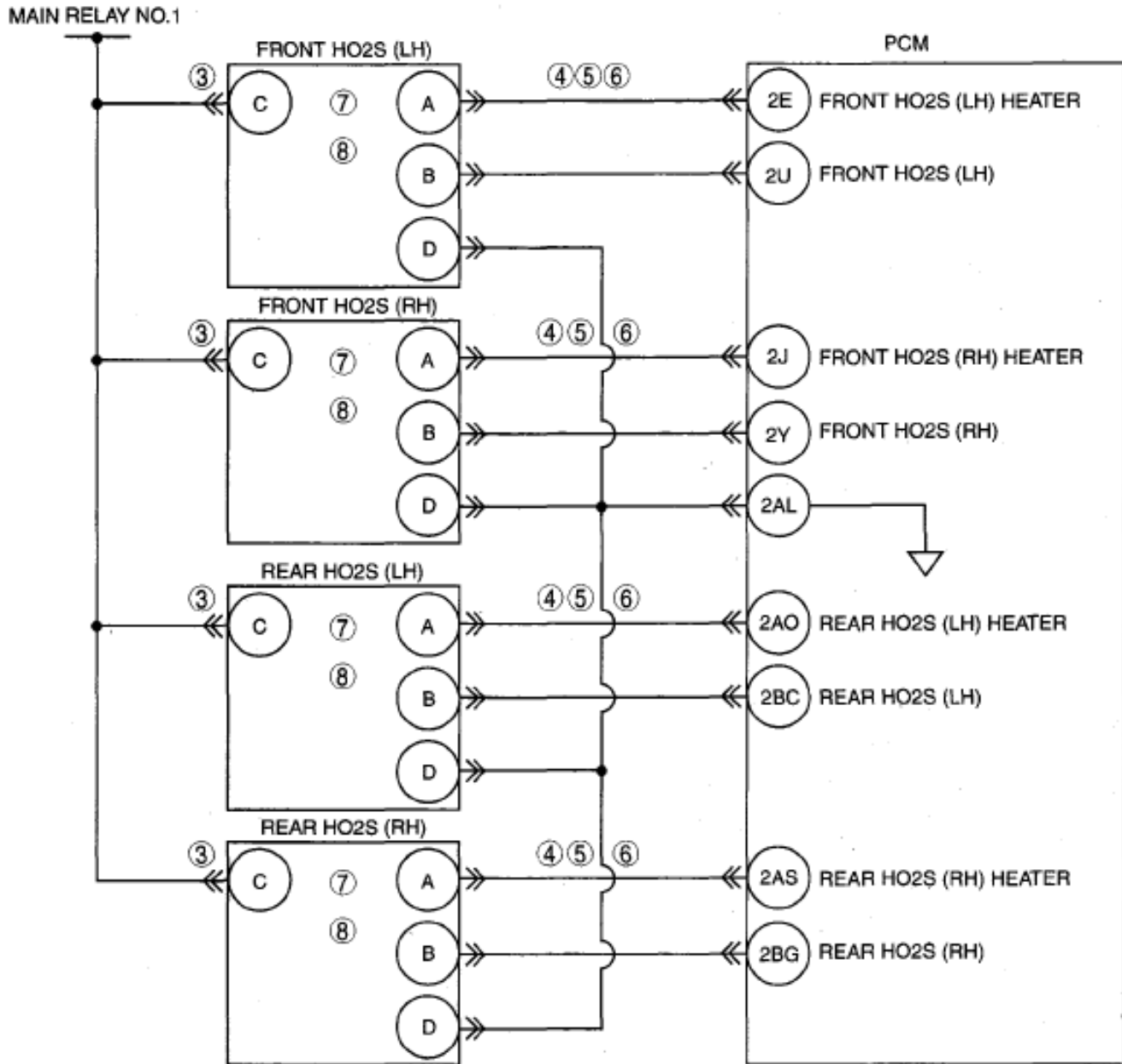

FRONT HO2S (LH, RH)  
WIRING HARNESS-SIDE  
CONNECTOR

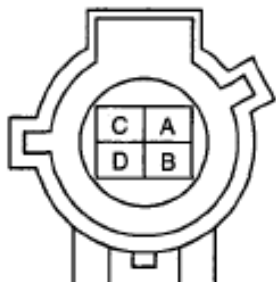

REAR HO2S (LH, RH)  
WIRING HARNESS-SIDE  
CONNECTOR

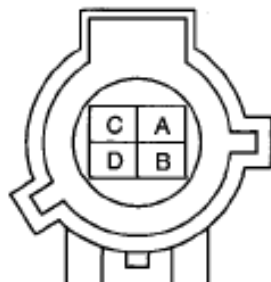

PCM  
WIRING HARNESS-SIDE CONNECTOR

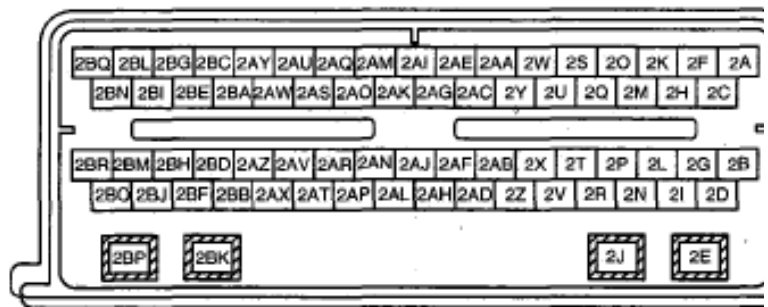

## 2007 Mazda CX-9 Grand Touring

2007 ENGINE PERFORMANCE On-Board Diagnostic (MZI-3.5) - CX-9

### DIAGNOSTIC PROCEDURE

#### DTC P0053, P0054, P0059, P0060 (MZI-3.5) DIAGNOSTIC PROCEDURE

STEP	INSPECTION	ACTION	
1	<b>VERIFY FREEZE FRAME DATA HAS BEEN RECORDED</b> <ul style="list-style-type: none"> <li>• Has FREEZE FRAME DATA been recorded?</li> </ul>	Yes	Go to the next step.
		No	Record FREEZE FRAME DATA on the repair order, then go to the next step.
2	<b>VERIFY RELATED REPAIR INFORMATION AVAILABILITY</b> <ul style="list-style-type: none"> <li>• Verify related Service Bulletins and/or on-line repair information availability.</li> <li>• Is any related Service Bulletins available?</li> </ul>	Yes	Perform repair or diagnosis according to the available Service Bulletins. <ul style="list-style-type: none"> <li>• If the vehicle is not repaired, go to the next step.</li> </ul>
		No	Go to the next step.
3	<b>INSPECT FOR POWER SUPPLY IN WIRING HARNESS</b> <ul style="list-style-type: none"> <li>• Disconnect the suspect HO2S connector.</li> <li>• Perform the KOEO self-test.</li> <li>• Measure the voltage between the suspect HO2S connector terminal A and C, on the wiring harness side.</li> <li>• Is the voltage more than 10 V?</li> </ul>	Yes	Turn the ignition switch off. Go to the next step.
		No	Repair or replace suspected part, then go to step 9.
4	<b>INSPECT HO2S HEATER FOR SHORT TO GROUND</b> <ul style="list-style-type: none"> <li>• Disconnect the PCM.</li> <li>• Measure the resistance between HO2S connector terminal A, the wiring harness side, and body ground.</li> <li>• Is the resistance more than 10 kilohms?</li> </ul>	Yes	Go to the next step.
		No	Repair or replace suspected part, Go to Step 9
5	<b>INSPECT HO2S HEATER FOR SHORT IN WIRING HARNESS</b> <ul style="list-style-type: none"> <li>• Measure the resistance between the following terminals:                             <ul style="list-style-type: none"> <li>○ HO2S terminal A (wiring</li> </ul> </li> </ul>	Yes	Go to the next step.

## 2007 Mazda CX-9 Grand Touring

2007 ENGINE PERFORMANCE On-Board Diagnostic (MZI-3.5) - CX-9

	<p>harness-side) and HO2S terminal C (wiring harness-side)</p> <ul style="list-style-type: none"> <li>○ HO2S terminal A (wiring harness-side) and HO2S terminal D (wiring harness-side)</li> <li>○ HO2S terminal A (wiring harness-side) and HO2S terminal B (wiring harness-side)</li> </ul> <ul style="list-style-type: none"> <li>● Are the resistances more than 10 kilohms?</li> </ul>	No	Repair or replace suspected part, Go to Step 9
6	<p><b>INSPECT HO2S HEATER CIRCUIT FOR OPEN CIRCUIT IN WIRING HARNESS</b></p> <ul style="list-style-type: none"> <li>● For DTC P0053 Measure resistance between PCM terminal 2J and front HO2S (RH) terminal A.</li> <li>● For DTC P0054 Measure resistance between PCM terminal 2AS and rear HO2S (RH) terminal A.</li> <li>● For DTC P0059 Measure resistance between PCM terminal 2E and front HO2S (LH) terminal A.</li> <li>● For DTC P0060 Measure resistance between PCM terminal 2AO and rear HO2S (LH) terminal A.</li> <li>● Is the resistance less than 5.0 ohms?</li> </ul>	Yes	Go to the next step.
		No	Repair or replace suspected part, Go to Step 9.
7	<p><b>INSPECT INTERNAL RESISTANCE OF HO2S HEATER</b></p> <ul style="list-style-type: none"> <li>● Measure the resistance between the suspect HO2S terminal A and C on the component side.</li> <li>● Is the resistance between 3-30 ohms?</li> </ul>	Yes	Go to the next step.
		No	<p>Replace the HO2S.            (See <b><u>FRONT HEATED OXYGEN SENSOR</u></b> .)            (HO2S) REMOVAL/INSTALLATION [MZI-3.5].)            (See <b><u>REAR HEATED OXYGEN SENSOR</u></b> .)            (HO2S) REMOVAL/INSTALLATION [MZI-3.5].)</p>

## 2007 Mazda CX-9 Grand Touring

2007 ENGINE PERFORMANCE On-Board Diagnostic (MZI-3.5) - CX-9

			Go to Step 9.
8	<b>INSPECT HO2S CASE FOR SHORT TO POWER SUPPLY, HTR, AND SIGNRTN</b> <ul style="list-style-type: none"> <li>• Measure the resistance between the suspect HO2S terminal A and D on the component side.</li> <li>• Measure the resistance between the suspect HO2S terminal A and body ground.</li> <li>• Is the resistance more than 10 kilohms?</li> </ul>	Yes	Replace the PCM. Go to the next step.
		No	Replace the HO2S. (See <b><u>FRONT HEATED OXYGEN SENSOR</u></b> .) (HO2S) REMOVAL/INSTALLATION [MZI-3.5].) (See <b><u>REAR HEATED OXYGEN SENSOR</u></b> .) (HO2S) REMOVAL/INSTALLATION [MZI-3.5].) Go to the next step.
9	<b>VERIFY TROUBLESHOOTING OF MISFIRE DTC HAS BEEN COMPLETED</b> <ul style="list-style-type: none"> <li>• Verify that all disconnected connectors reconnected.</li> <li>• Turn the ignition switch to the ON position (Engine off).</li> <li>• Clear the DTC from the PCM memory using the M-MDS.</li> <li>• Start the engine and run it at idle.</li> <li>• Retrieve DTCs using the M-MDS.</li> <li>• Is the PENDING CODE for this DTC present?</li> </ul>	Yes	Replace the PCM, then go to the next step. (see <b><u>PCM REMOVAL/INSTALLATION [MZI-3.5]</u></b> .)
		No	Go to the next step.
10	<b>VERIFY AFTER REPAIR PROCEDURE</b> <ul style="list-style-type: none"> <li>• Perform "AFTER REPAIR PROCEDURE".</li> </ul> (See <b><u>AFTER REPAIR PROCEDURE [MZI-3.5]</u></b> .)  <ul style="list-style-type: none"> <li>• Are any DTC present?</li> </ul>	Yes	Go to the applicable DTC inspection. (See <b><u>DTC TABLE [MZI-3.5]</u></b> .)
		No	Troubleshooting completed.

### DTC P0068 [MZI-3.5]

#### DTC P0068 (MZI-3.5) DETECTION CONDITION AND POSSIBLE CAUSES

<b>DTC P0068</b>	<b>MAP/MAF-throttle position correlation</b>
	<ul style="list-style-type: none"> <li>• The PCM monitors a vehicle operation rationality check by comparing</li> </ul>

## 2007 Mazda CX-9 Grand Touring

2007 ENGINE PERFORMANCE On-Board Diagnostic (MZI-3.5) - CX-9

<b>DETECTION CONDITION</b>	sensed throttle position to mass air flow readings. If during a KOER self-test, the comparison of the TP sensor and MAF sensor readings are not consistent with the calibrated load values, test fails and a DTC is stored in continuous memory.
<b>POSSIBLE CAUSE</b>	<ul style="list-style-type: none"> <li>• Air leak between MAF sensor and throttle body</li> <li>• TP sensor or MAF sensor malfunction</li> <li>• TP sensor not seated correctly</li> </ul>

### DIAGNOSTIC PROCEDURE

#### DTC P0068 (MZI-3.5) DIAGNOSTIC PROCEDURE

STEP	INSPECTION		ACTION
1	<b>VERIFY FREEZE FRAME DATA HAS BEEN RECORDED</b> <ul style="list-style-type: none"> <li>• Has FREEZE FRAME DATA been recorded?</li> </ul>	Yes	Go to next step.
		No	Record FREEZE FRAME DATA on the repair order, then go to next step.
2	<b>VERIFY RELATED REPAIR INFORMATION AVAILABILITY</b> <ul style="list-style-type: none"> <li>• Verify related Service Bulletins availability.</li> <li>• Is any related Service Bulletins available?</li> </ul>	Yes	Perform repair or diagnosis according to available Service Bulletins. <ul style="list-style-type: none"> <li>• If vehicle is not repaired, go to next step.</li> </ul>
		No	Go to next step.
3	<b>VERIFY RELATED PENDING CODE OR STORED DTC</b> <ul style="list-style-type: none"> <li>• Verify the related PENDING CODE or stored DTCs.</li> <li>• Are other DTCs present?</li> </ul>	Yes	Go to appropriate DTC inspection. (See <b><u>DTC TABLE [MZI-3.5]</u></b> .)
		No	Go to next step.
4	<b>INSPECT FOR INLET AIR LEAKS</b> <ul style="list-style-type: none"> <li>• Listen for air noise around the MAF sensor and throttle body while the engine is running.</li> <li>• Is a concern present?</li> </ul>	Yes	Repair as necessary. Go to Step 8.
		No	Go to next step.
5	<b>INSPECT FOR TP2 SIGNAL HIGH VERSUS LOAD WHILE DRIVING THE VEHICLE</b> <ul style="list-style-type: none"> <li>• Turn the ignition switch to the ON position (Engine running).</li> <li>• Access the TP2 and LOAD PIDs using the M-MDS.</li> </ul>	Yes	Replace the malfunctioning part, then go to Step 8.
		No	Go to next step.



## 2007 Mazda CX-9 Grand Touring

2007 ENGINE PERFORMANCE On-Board Diagnostic (MZI-3.5) - CX-9

	<ul style="list-style-type: none"> <li>Is the TP2 PID more than 2.44 V and the LOAD PID less than 30%?</li> </ul>		
6	<p><b>INSPECT FOR TP2 SIGNAL LOW VERSUS LOAD WHILE DRIVING THE VEHICLE</b></p> <ul style="list-style-type: none"> <li>Turn the ignition switch to the ON position (Engine running).</li> <li>Access the PCM and monitor the TP2 and LOAD PIDs</li> <li>Is the TP2 PID less than 0.24 V and the LOAD PID more than 55%?</li> </ul>	Yes	Repair or replace the malfunctioning part, then go to Step 8.
		No	Go to next step.
7	<p><b>INSPECT FOR SELF-TEST DTCS</b></p> <ul style="list-style-type: none"> <li>Turn the ignition switch to the ON position (Engine running).</li> <li>Clear DTC from memory using M-MDS.</li> <li>Drive the vehicle while exercising the throttle.</li> <li>Retrieve the continuous memory DTCs.</li> <li>Are any DTCs present?</li> </ul>	Yes	Replace the malfunctioning part, then go to the next step.
		No	Perform the "INTERMITTENT CONCERN TROUBLESHOOTING". Then go to the next step.
8	<p><b>VERIFY TROUBLESHOOTING OF DTC P0068 HAS BEEN COMPLETED</b></p> <ul style="list-style-type: none"> <li>Verify that all disconnected connectors reconnected.</li> <li>Clear DTC from memory using M-MDS.</li> <li>Start engine.</li> <li>Perform "KOEK/KOER self-test"</li> </ul> <p>(See <b><u>KOEK/KOER SELF TEST [MZI-3.5]</u></b>.)</p> <ul style="list-style-type: none"> <li>Is same DTC present?</li> </ul>	Yes	Replace PCM, then go to next step.
		No	Go to next step.
9	<p><b>VERIFY AFTER REPAIR PROCEDURE</b></p> <ul style="list-style-type: none"> <li>Perform "AFTER REPAIR PROCEDURE".</li> </ul>	Yes	Go to the applicable DTC inspection. (See <b><u>DTC TABLE [MZI-3.5]</u></b> .)

## 2007 Mazda CX-9 Grand Touring

2007 ENGINE PERFORMANCE On-Board Diagnostic (MZI-3.5) - CX-9

<p>(See <b><u>AFTER REPAIR PROCEDURE [MZI-3.5].</u></b>)</p> <ul style="list-style-type: none"><li>• Are any DTC present?</li></ul>	No	Troubleshooting completed.
---	----	----------------------------

### DTC P0102 [MZI-3.5]

#### DTC P0102 (MZI-3.5) DETECTION CONDITION AND POSSIBLE CAUSES

DTC P0102	MAF circuit low input
<b>DETECTION CONDITION</b>	<ul style="list-style-type: none"><li>• The MAF sensor circuit is monitored by the PCM for low air flow (or voltage) in through the CCM. If during KOER the air flow (or voltage) changes below a mini calibrated limit, the test fails.</li></ul>
<b>POSSIBLE CAUSE</b>	<ul style="list-style-type: none"><li>• Connector or terminal malfunction</li><li>• Open circuit wiring harness between MAF sensor terminal A and main relay No.1 terminal D</li><li>• Open circuit wiring harness between MAF sensor terminal C and PCM terminal 1</li><li>• Open circuit wiring harness between MAF sensor terminal D and PCM terminal 1</li><li>• Open circuit wiring harness between MAF sensor terminal B and body ground</li><li>• Short to ground circuit between MAF sensor terminal D and PCM terminal 1AN</li><li>• Intake air leak (near the MAF sensor)</li><li>• A closed throttle indication</li><li>• MAF sensor malfunction</li></ul>

## 2007 Mazda CX-9 Grand Touring

2007 ENGINE PERFORMANCE On-Board Diagnostic (MZI-3.5) - CX-9

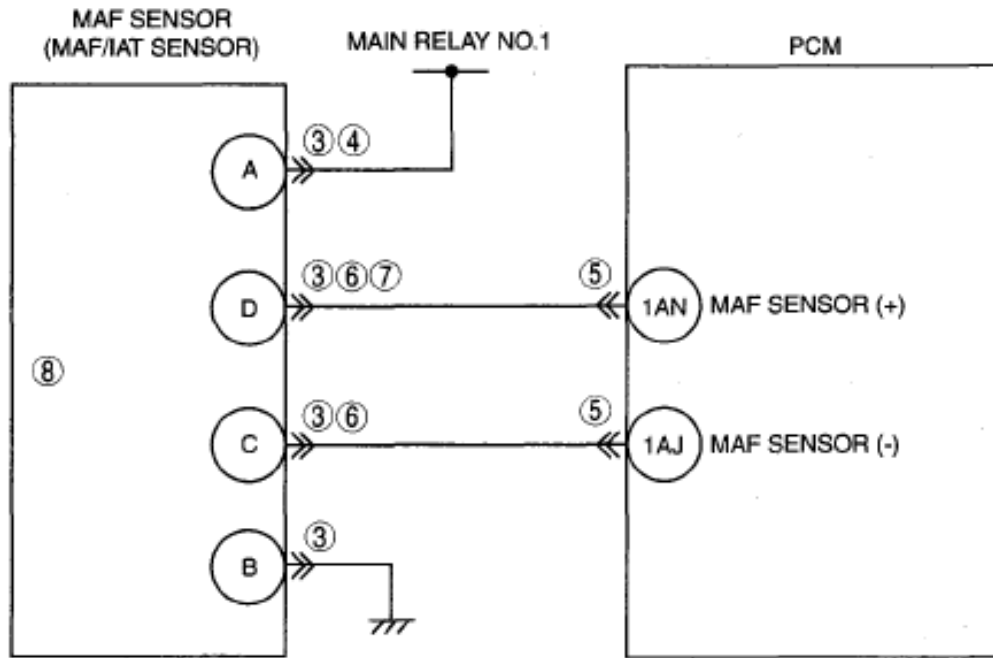

MAF/IAT SENSOR MAIN RELAY NO.1 WIRING HARNESS-SIDE CONNECTOR

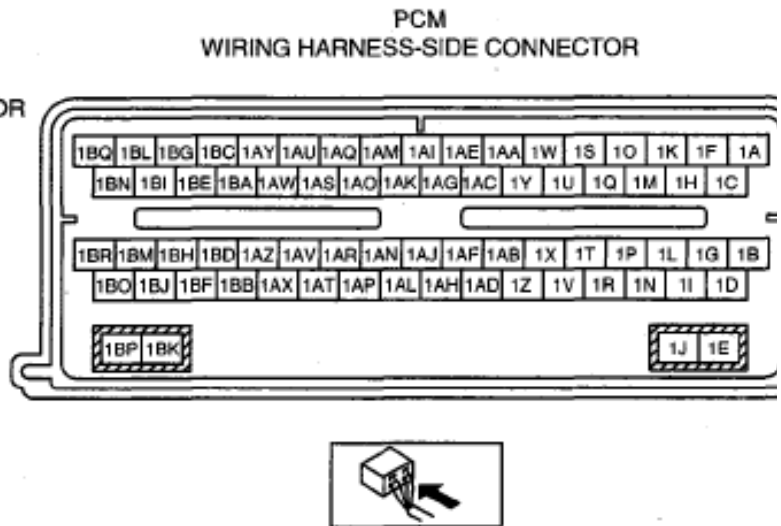
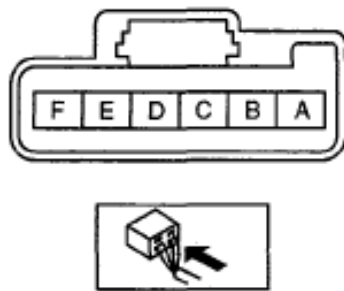
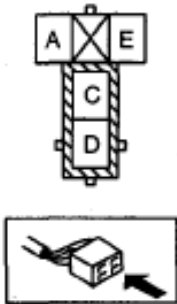

### DIAGNOSTIC PROCEDURE

#### DTC P0102 (MZI-3.5) DIAGNOSTIC PROCEDURE

STEP	INSPECTION		ACTION
1	<b>VERIFY FREEZE FRAME DATA HAS BEEN RECORDED</b>  • Has FREEZE FRAME DATA been recorded?	Yes	Go to the next step.
		No	Record FREEZE FRAME DATA on the repair order, then go to the next step.
2	<b>VERIFY RELATED REPAIR</b>	Yes	Perform repair or diagnosis according to

## 2007 Mazda CX-9 Grand Touring

2007 ENGINE PERFORMANCE On-Board Diagnostic (MZI-3.5) - CX-9

	<p><b>INFORMATION AVAILABILITY</b></p> <ul style="list-style-type: none"> <li>• Verify related Service Bulletins and/or on-line repair information availability.</li> <li>• Is any related Service Bulletins available?</li> </ul>		<p>the available Service Bulletins.</p> <ul style="list-style-type: none"> <li>• If the vehicle is not repaired, go to the next step.</li> </ul>
		No	Go to the next step.
3	<p><b>INSPECT MAF SENSOR CONNECTOR FOR POOR CONNECTION</b></p> <ul style="list-style-type: none"> <li>• Turn the ignition switch off.</li> <li>• Disconnect the MAF/IAT sensor connector.</li> <li>• Inspect for poor connection (such as damaged/pulled-out pins, corrosion).</li> <li>• Are there any malfunction?</li> </ul>	Yes	Repair or replace suspected part, then go to Step 10.
		No	Go to the next step.
4	<p><b>INSPECT POWER SUPPLY CIRCUIT FOR OPEN CIRCUIT</b></p> <ul style="list-style-type: none"> <li>• Turn the ignition switch to the ON position (Engine off).</li> <li>• Measure the voltage between MAF sensor terminal A and body ground.</li> <li>• Is the voltage B+?</li> </ul>	Yes	Go to the next step.
		No	Repair or replace suspected part, then go to Step 10.
5	<p><b>INSPECT PCM CONNECTOR FOR POOR CONNECTION</b></p> <ul style="list-style-type: none"> <li>• Turn the ignition switch off.</li> <li>• Disconnect PCM connector.</li> <li>• Inspect for poor connection (such as damaged/pulled-out pins, corrosion).</li> <li>• Are there any malfunction?</li> </ul>	Yes	Repair or replace suspected part, then go to Step 10.
		No	Go to the next step.
6	<p><b>INSPECT MAF SENSOR SIGNAL CIRCUIT FOR OPEN CIRCUIT</b></p> <ul style="list-style-type: none"> <li>• Remove PCM with PCM connector connected.</li> <li>• Inspect for continuity between the following circuits:</li> </ul>	Yes	Go to the next step.
		No	Repair or replace suspected part, then go to Step 10.

## 2007 Mazda CX-9 Grand Touring

2007 ENGINE PERFORMANCE On-Board Diagnostic (MZI-3.5) - CX-9

	<ul style="list-style-type: none"> <li>○ MAF sensor terminal C (wiring harness-side) and PCM terminal 1AJ (wiring harness-side)</li> <li>○ MAF sensor terminal D (wiring harness-side) and PCM terminal 1AN (wiring harness-side)</li> </ul> <ul style="list-style-type: none"> <li>● Are there continuity?</li> </ul>		
7	<p><b>INSPECT MAF SENSOR SIGNAL CIRCUIT FOR SHORT TO GROUND</b></p> <ul style="list-style-type: none"> <li>● Turn the ignition switch off.</li> <li>● Disconnect the MAF/IAT sensor and PCM connector.</li> <li>● Inspect continuity between following circuits:                             <ul style="list-style-type: none"> <li>○ MAF sensor connector terminal D and body ground</li> </ul> </li> <li>● Are there continuity?</li> </ul>	Yes	Repair or replace suspected part, then go to the Step 10.
		No	Go to the next step.
8	<p><b>INSPECT MAF SENSOR GROUND CIRCUIT FOR OPEN CIRCUIT</b></p> <ul style="list-style-type: none"> <li>● Inspect continuity between MAF sensor terminal B and body ground.</li> <li>● Are there continuity?</li> </ul>	Yes	Go to the next step.
		No	Repair or replace suspected part, then go to Step 10.
9	<p><b>INSPECT THE MAF SENSOR</b></p> <ul style="list-style-type: none"> <li>● Inspect the MAF sensor&gt;</li> </ul> <p>(see <u>MASS AIR FLOW (MAF.)</u> SENSOR INSPECTION [MZI-3.5].)</p> <ul style="list-style-type: none"> <li>● Are there any malfunction?</li> </ul>	Yes	Replace the MAF/IAT sensor, then go to the next step. (see <u>MASS AIR FLOW (MAF)/INTAKE AIR TEMPERATURE (IAT) SENSOR REMOVAL/INSTALLATION [MZI-3.5].</u> )
		No	Go to the next step.
10	<p><b>VERIFY TROUBLESHOOTING OF DTC P0102 HAS BEEN COMPLETED</b></p> <ul style="list-style-type: none"> <li>● Verify that all disconnected connectors reconnected.</li> </ul>	Yes	Replace PCM, then go to the next step. (see <u>PCM REMOVAL/INSTALLATION [MZI-3.5].</u> )

## 2007 Mazda CX-9 Grand Touring

2007 ENGINE PERFORMANCE On-Board Diagnostic (MZI-3.5) - CX-9

	<ul style="list-style-type: none"> <li>• Turn the ignition switch to the ON position (Engine off).</li> <li>• Clear the DTC from the PCM memory using the M-MDS.</li> <li>• Start engine and warm it up completely.</li> <li>• Is same DTC present?</li> </ul>	No	Go to the next step.
11	<p><b>VERIFY AFTER REPAIR PROCEDURE</b></p> <ul style="list-style-type: none"> <li>• Perform "AFTER REPAIR PROCEDURE".</li> </ul> <p>(See <b><u>AFTER REPAIR PROCEDURE [MZI-3.5].</u></b>)</p> <ul style="list-style-type: none"> <li>• Are any DTC present?</li> </ul>	Yes	Go to the applicable DTC inspection. (See <b><u>DTC TABLE [MZI-3.5].</u></b> )
		No	Troubleshooting completed.

### DTC P0103 [MZI-3.5]

#### DTC P0103 (MZI-3.5) DETECTION CONDITION AND POSSIBLE CAUSES

<b>DTC P0103</b>	<b>MAF circuit high input</b>
<b>DETECTION CONDITION</b>	<ul style="list-style-type: none"> <li>• The MAF sensor circuit is monitored by the PCM for high air flow (or voltage) in through the CCM. If during KOEO, or KOER, the air flow (or voltage) changes at a maximum calibrated limit, the test fails.</li> </ul>
<b>POSSIBLE CAUSE</b>	<ul style="list-style-type: none"> <li>• Short to power supply in wiring harness between MAF sensor terminal D and PCM terminal 1AN</li> <li>• MAF sensor malfunction</li> <li>• Connector or terminal malfunction</li> </ul>

# 2007 Mazda CX-9 Grand Touring

2007 ENGINE PERFORMANCE On-Board Diagnostic (MZI-3.5) - CX-9

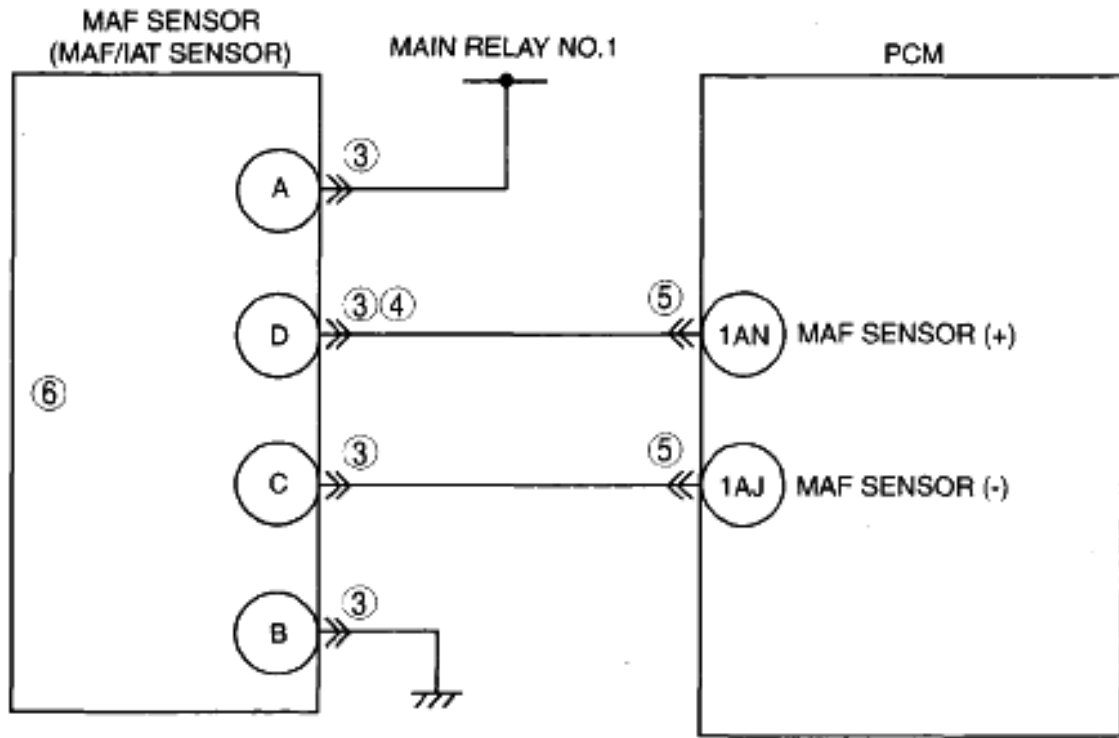

MAF/IAT SENSOR WIRING HARNESS-SIDE CONNECTOR

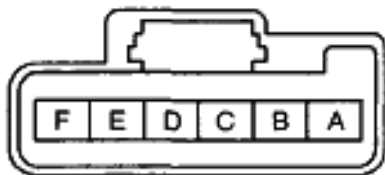

PCM WIRING HARNESS-SIDE CONNECTOR

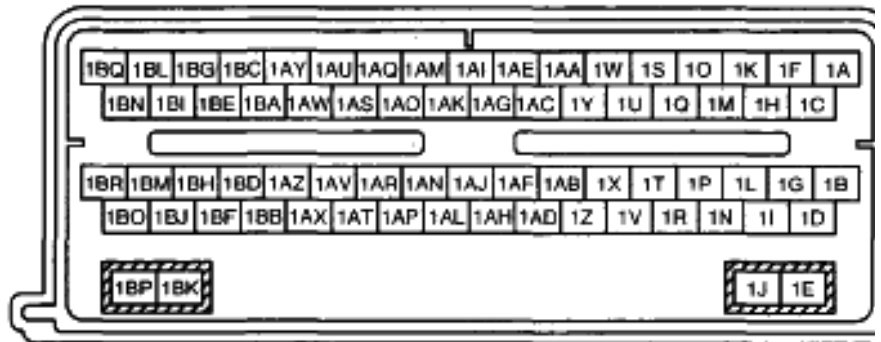

## DIAGNOSTIC PROCEDURE

### DTC P0103 (MZI-3.5) DIAGNOSTIC PROCEDURE

STEP	INSPECTION		ACTION
1	VERIFY FREEZE FRAME DATA HAS BEEN RECORDED	Yes	Go to the next step.

## 2007 Mazda CX-9 Grand Touring

2007 ENGINE PERFORMANCE On-Board Diagnostic (MZI-3.5) - CX-9

	<ul style="list-style-type: none"> <li>• Has FREEZE FRAME DATA been recorded?</li> </ul>	No	Record FREEZE FRAME DATA on the repair order, then go to the next step.
2	<b>VERIFY RELATED REPAIR INFORMATION AVAILABILITY</b> <ul style="list-style-type: none"> <li>• Verify related Service Bulletins and/or on-line repair information availability.</li> <li>• Is any related Service Bulletins available?</li> </ul>	Yes	Perform repair or diagnosis according to the available Service Bulletins. <ul style="list-style-type: none"> <li>• If the vehicle is not repaired, go to the next step.</li> </ul>
		No	Go to the next step.
3	<b>INSPECT MAF SENSOR CONNECTOR FOR POOR CONNECTION</b> <ul style="list-style-type: none"> <li>• Turn the ignition switch off.</li> <li>• Disconnect the MAF/IAT sensor connector.</li> <li>• Inspect for poor connection (such as damaged/pulled-out pins, corrosion).</li> <li>• Are there any malfunction?</li> </ul>	Yes	Repair or replace suspected part, then go to Step 7.
		No	Go to the next step.
4	<b>INSPECT MAF SIGNAL CIRCUIT FOR SHORT TO POWER SUPPLY</b> <ul style="list-style-type: none"> <li>• Turn the ignition switch to the ON position (Engine off).</li> <li>• Measure voltage between MAF sensor terminal D (wiring harness-side) and body ground.</li> <li>• Is voltage B+?</li> </ul>	No	Repair or replace suspected part, then go to Step 7.
		Yes	Go to the next step.
5	<b>INSPECT PCM CONNECTOR FOR POOR CONNECTION</b> <ul style="list-style-type: none"> <li>• Turn the ignition switch off.</li> <li>• Disconnect PCM connector.</li> <li>• Inspect for poor connection (such as damaged/pulled-out pins, corrosion).</li> <li>• Are there any malfunction?</li> </ul>	No	Repair or replace suspected part, then go to Step 7.
		Yes	Go to the next step.
6	<b>INSPECT THE MAF SENSOR</b> <ul style="list-style-type: none"> <li>• Inspect the MAF sensor.</li> </ul>	Yes	Replace the MAF/IAT sensor (see <b><u>MASS AIR FLOW (MAF)/INTAKE AIR TEMPERATURE (IAT) SENSOR REMOVAL/INSTALLATION [MZI-</u></b>



## 2007 Mazda CX-9 Grand Touring

2007 ENGINE PERFORMANCE On-Board Diagnostic (MZI-3.5) - CX-9

	(see <b>MASS AIR FLOW (MAF.)</b> )		<b>3.5].</b> ), then go to Step 7.
	SENSOR INSPECTION [MZI-3.5].)	No	Go to the next step.
	<ul style="list-style-type: none"> <li>• Is there malfunction?</li> </ul>		
7	<b>VERIFY TROUBLESHOOTING OF DTC P0103 HAS BEEN COMPLETED</b> <ul style="list-style-type: none"> <li>• Verify that all disconnected connectors reconnected.</li> <li>• Turn the ignition switch to the ON position (Engine off).</li> <li>• Clear the DTC from the PCM memory using the M-MDS.</li> <li>• Start engine and warm it up completely.</li> <li>• Is same DTC present?</li> </ul>	Yes	Replace PCM, then go to the next step. (see <b>PCM REMOVAL/INSTALLATION [MZI-3.5]</b> .)
		No	Go to the next step.
8	<b>VERIFY AFTER REPAIR PROCEDURE</b> <ul style="list-style-type: none"> <li>• Perform "AFTER REPAIR PROCEDURE".</li> </ul> <p>(See <b>AFTER REPAIR PROCEDURE [MZI-3.5].</b>)</p> <ul style="list-style-type: none"> <li>• Are any DTC present?</li> </ul>	Yes	Go to the applicable DTC inspection. (See <b>DTC TABLE [MZI-3.5].</b> )
		No	Troubleshooting completed.

### DTC P0104 [MZI-3.5]

#### DTC P0104 (MZI-3.5) DETECTION CONDITION AND POSSIBLE CAUSES

<b>DTC P0104</b>	<b>MAF circuit intermittent/erratic</b>
<b>DETECTION CONDITION</b>	<ul style="list-style-type: none"> <li>• A concern exists in the MAF sensor circuit, or the air tube containing the sensor, causing an incorrect air flow reading.</li> </ul>
<b>POSSIBLE CAUSE</b>	<ul style="list-style-type: none"> <li>• Air leaks in the tube from the MAF to the throttle body</li> <li>• Open circuit wiring harness between MAF sensor terminal C and PCM terminal 1</li> <li>• Open circuit wiring harness between MAF sensor terminal D and PCM terminal 1</li> <li>• Short to power supply in wiring harness between MAF sensor terminal C and PCM terminal 1AJ</li> <li>• Short to power supply in wiring harness between MAF sensor terminal D and PCM terminal 1AN</li> </ul>

# 2007 Mazda CX-9 Grand Touring

2007 ENGINE PERFORMANCE On-Board Diagnostic (MZI-3.5) - CX-9

- Short to ground circuit between MAF sensor terminal C and PCM terminal 1AJ
- Short to ground circuit between MAF sensor terminal D and PCM terminal 1AN
- Connector or terminal malfunction

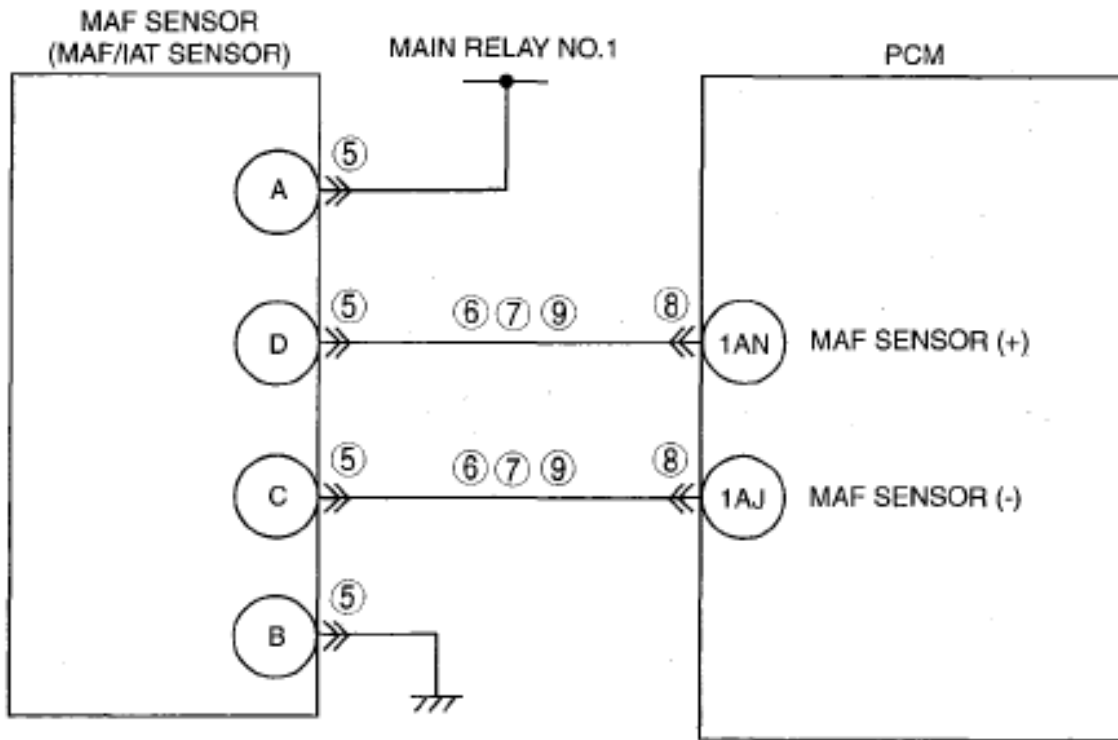

MAF/IAT SENSOR WIRING HARNESS-SIDE CONNECTOR

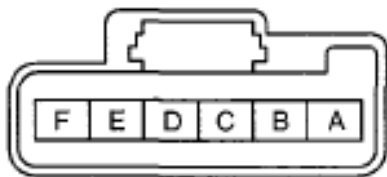

PCM WIRING HARNESS-SIDE CONNECTOR

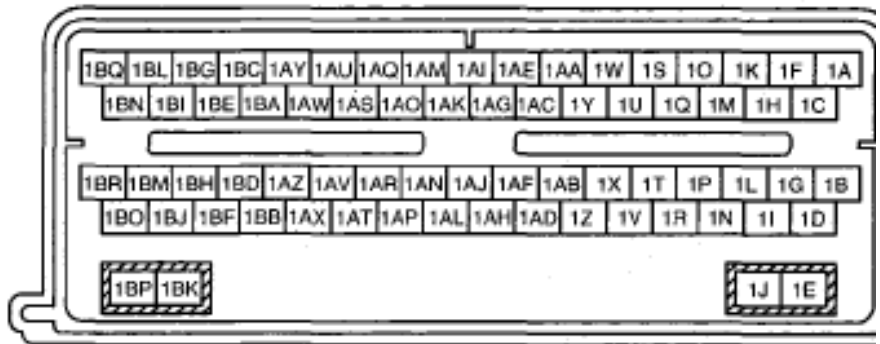

## DIAGNOSTIC PROCEDURE

## 2007 Mazda CX-9 Grand Touring

2007 ENGINE PERFORMANCE On-Board Diagnostic (MZI-3.5) - CX-9

### DTC P0104 (MZI-3.5) DIAGNOSTIC PROCEDURE

STEP	INSPECTION		ACTION
1	<b>VERIFY FREEZE FRAME DATA HAS BEEN RECORDED</b> <ul style="list-style-type: none"> <li>• Has FREEZE FRAME DATA been recorded?</li> </ul>	Yes	Go to next step.
		No	Record FREEZE FRAME DATA on the repair order, then go to next step.
2	<b>VERIFY RELATED REPAIR INFORMATION AVAILABILITY</b> <ul style="list-style-type: none"> <li>• Verify related Service Bulletins availability.</li> <li>• Is any related Service Bulletins available?</li> </ul>	Yes	Perform repair or diagnosis according to available Service Bulletins. <ul style="list-style-type: none"> <li>• If vehicle is not repaired, go to next step.</li> </ul>
		No	Go to next step.
3	<b>VERIFY RELATED PENDING CODE OR STORED DTC</b> <ul style="list-style-type: none"> <li>• Verify the related PENDING CODE or stored DTCs.</li> <li>• Are other DTCs present?</li> </ul>	Yes	Go to appropriate DTC inspection. (See <b>DTC TABLE [MZI-3.5]</b> .)
		No	Go to next step.
4	<b>INSPECT AIR SUCTIONING BETWEEN MAF SENSOR AND TP SENSOR</b> <ul style="list-style-type: none"> <li>• Inspect for major leaks, cracks and openings between MAF sensor and throttle body.</li> <li>• Are there any malfunction?</li> </ul>	Yes	Repair or replace the malfunctioning part, then go to Step 10.
		No	Go to next step.
5	<b>INSPECT MAF SENSOR CONNECTOR FOR POOR CONNECTION</b> <ul style="list-style-type: none"> <li>• Turn the ignition switch off.</li> <li>• Disconnect the MAF/IAT sensor connector.</li> <li>• Inspect for poor connection (such as damaged/pulled-out pins, corrosion).</li> <li>• Are there any malfunction?</li> </ul>	Yes	Repair or replace the malfunctioning part, then go to Step 10.
		No	Go to next step.
6	<b>INSPECT MAF SIGNAL CIRCUIT FOR SHORT TO POWER SUPPLY</b> <ul style="list-style-type: none"> <li>• Turn the ignition switch to the ON position (Engine off).</li> </ul>	Yes	Repair or replace the malfunctioning part, then go to Step 10.

## 2007 Mazda CX-9 Grand Touring

2007 ENGINE PERFORMANCE On-Board Diagnostic (MZI-3.5) - CX-9

	<ul style="list-style-type: none"> <li>• Measure voltage between the following terminals:                             <ul style="list-style-type: none"> <li>○ MAF sensor terminal C (wiring harness-side) and body ground</li> <li>○ MAF sensor terminal D (wiring harness-side) and body ground</li> </ul> </li> <li>• Are there voltage B+?</li> </ul>	No	Go to next step.
7	<p><b>INSPECT MAF SENSOR SIGNAL CIRCUIT FOR SHORT TO GROUND</b></p> <ul style="list-style-type: none"> <li>• Turn the ignition switch off.</li> <li>• Disconnect the MAF/IAT sensor and PCM connector.</li> <li>• Inspect for continuity between the following circuits:                                     <ul style="list-style-type: none"> <li>○ MAF sensor terminal C (wiring harness-side) and body ground</li> <li>○ MAF sensor terminal D (wiring harness-side) and body ground</li> </ul> </li> <li>• Are there continuity?</li> </ul>	Yes	Repair or replace the malfunctioning part, then go to Step 10.
		No	Go to next step.
8	<p><b>INSPECT PCM CONNECTOR FOR POOR CONNECTION</b></p> <ul style="list-style-type: none"> <li>• Turn the ignition switch off.</li> <li>• Disconnect the MAF/IAT sensor connector.</li> <li>• Inspect for poor connection (such as damaged/pulled-out pins, corrosion).</li> <li>• Are there any malfunction?</li> </ul>	Yes	Repair or replace the malfunctioning part, then go to Step 10.
		No	Go to next step.
9	<p><b>INSPECT MAF SENSOR CIRCUIT FOR OPEN CIRCUIT</b></p> <ul style="list-style-type: none"> <li>• Turn the ignition switch off.</li> <li>• Disconnect the PCM connector.</li> <li>• Disconnect the MAF/IAT sensor connector.</li> </ul>	Yes	Go to the next step.
		No	Repair or replace suspected part, then go to the next step.

## 2007 Mazda CX-9 Grand Touring

2007 ENGINE PERFORMANCE On-Board Diagnostic (MZI-3.5) - CX-9

	<ul style="list-style-type: none"> <li>• Inspect for continuity between the following terminals:                             <ul style="list-style-type: none"> <li>○ MAF sensor terminal C and PCM terminal 1AJ</li> <li>○ MAF sensor terminal D and PCM terminal 1AN</li> </ul> </li> <li>• Are there continuity?</li> </ul>		
10	<p><b>VERIFY TROUBLESHOOTING OF DTC P0104 HAS BEEN COMPLETED</b></p> <ul style="list-style-type: none"> <li>• Verify that all disconnected connectors reconnected.</li> <li>• Clear DTC from memory using M-MDS.</li> <li>• Start the engine.</li> <li>• Perform the "KOEO/KOER self-test"</li> </ul> <p>(See <b>KOEO/KOER SELF TEST [MZI-3.5]</b>.)</p>	Yes	Replace the PCM, then go to next step. (see <b>PCM REMOVAL/INSTALLATION [MZI-3.5]</b> .)
		No	Go to next step.
11	<p><b>VERIFY AFTER REPAIR PROCEDURE</b></p> <ul style="list-style-type: none"> <li>• Perform the "AFTER REPAIR PROCEDURE".</li> </ul> <p>(See <b>AFTER REPAIR PROCEDURE [MZI-3.5]</b>.)</p>	Yes	Go to the applicable DTC inspection. (See <b>DTC TABLE [MZI-3.5]</b> .)
		No	Troubleshooting completed.
	<ul style="list-style-type: none"> <li>• Are any DTCs present?</li> </ul>		

### DTC P0111 [MZI-3.5]

#### DTC P0111 (MZI-3.5) DETECTION CONDITION AND POSSIBLE CAUSES

DTC P0111	IAT sensor circuit range/performance
<b>DETECTION CONDITION</b>	<ul style="list-style-type: none"> <li>• Indicates the IAT rationality test has failed. This DTC indicates that the IAT value is higher than a calibrated value and could prevent 1 or more on-board diagnostic (OBD) monitors from completing. The PCM runs this logic after an engine off and a calibrated soak period (typically 6 hours) This soak period allows IAT and CHT to stabilize and not differ by more than a calibrated value. DTC P0111 is set when: the IAT at engine start exceeds</li> </ul>

## 2007 Mazda CX-9 Grand Touring

2007 ENGINE PERFORMANCE On-Board Diagnostic (MZI-3.5) - CX-9

	the CHT by more than a calibrated value, typically 17 °C {30 °F}.
<b>POSSIBLE CAUSE</b>	<ul style="list-style-type: none"> <li>• IAT sensor malfunction</li> </ul>

### DIAGNOSTIC PROCEDURE

#### DTC P0111 (MZI-3.5) DIAGNOSTIC PROCEDURE

STEP	INSPECTION	ACTION	
1	<b>VERIFY FREEZE FRAME DATA HAS BEEN RECORDED</b> <ul style="list-style-type: none"> <li>• Has FREEZE FRAME DATA been recorded?</li> </ul>	Yes	Go to the next step.
		No	Record FREEZE FRAME DATA on the repair order, then go to the next step.
2	<b>VERIFY RELATED REPAIR INFORMATION AVAILABILITY</b> <ul style="list-style-type: none"> <li>• Verify related Service Bulletins and/or on-line repair information availability.</li> <li>• Is any related Service Bulletins available?</li> </ul>	Yes	Perform repair or diagnosis according to the available Service Bulletins. <ul style="list-style-type: none"> <li>• If the vehicle is not repaired, go to the next step.</li> </ul>
		No	Go to the next step.
3	<b>INSPECT IAT SENSOR</b> <ul style="list-style-type: none"> <li>• Inspect IAT sensor.</li> </ul> (see <b><u>INTAKE-AIR SYSTEM REMOVAL/INSTALLATION [MZI-3.5]</u></b> .) <ul style="list-style-type: none"> <li>• Is IAT sensor normal?</li> </ul>	Yes	Go to the next step.
		No	Replace MAF/IAT sensor, then go to the next step. (see <b><u>MASS AIR FLOW (MAF)/INTAKE AIR TEMPERATURE (IAT) SENSOR REMOVAL/INSTALLATION [MZI-3.5]</u></b> .)
4	<b>VERIFY TROUBLESHOOTING OF DTC P0111 HAS BEEN COMPLETED</b> <ul style="list-style-type: none"> <li>• Verify that all disconnected connectors reconnected.</li> <li>• Clear the DTC from the PCM memory using the M-MDS.</li> <li>• Start engine and run engine under FREEZE FRAME DATA condition.</li> <li>• Is PENDING CODE for this DTC present?</li> </ul>	Yes	Replace PCM, then go to the next step. (see <b><u>PCM REMOVAL/INSTALLATION [MZI-3.5]</u></b> .)
		No	Go to the next step.
5	<b>VERIFY AFTER REPAIR PROCEDURE</b> <ul style="list-style-type: none"> <li>• Perform "AFTER REPAIR</li> </ul>	Yes	Go to the applicable DTC inspection. (See <b><u>DTC TABLE [MZI-3.5]</u></b> .)

## 2007 Mazda CX-9 Grand Touring

2007 ENGINE PERFORMANCE On-Board Diagnostic (MZI-3.5) - CX-9

	PROCEDURE"  (See <b><u>AFTER REPAIR PROCEDURE [MZI-3.5].</u></b> )  • Are any DTC present?	No	Troubleshooting completed.
--	--	----	----------------------------

### DTC P0112 [MZI-3.5]

#### DTC P0112 (MZI-3.5) DETECTION CONDITION AND POSSIBLE CAUSES

<b>DTC P0112</b>	<b>IAT sensor circuit low input</b>
<b>DETECTION CONDITION</b>	<ul style="list-style-type: none"><li>• Indicates that the sensor signal is less than the self-test minimum. The IAT sensor minimum is <b>0.2 V or 121 °C {250 °F}</b>.</li></ul>
<b>POSSIBLE CAUSE</b>	<ul style="list-style-type: none"><li>• Short to ground circuit between MAF/IAT sensor terminal F and PCM terminal 1.</li><li>• IAT sensor malfunction</li><li>• Connector or terminal malfunction</li></ul>

## 2007 Mazda CX-9 Grand Touring

2007 ENGINE PERFORMANCE On-Board Diagnostic (MZI-3.5) - CX-9

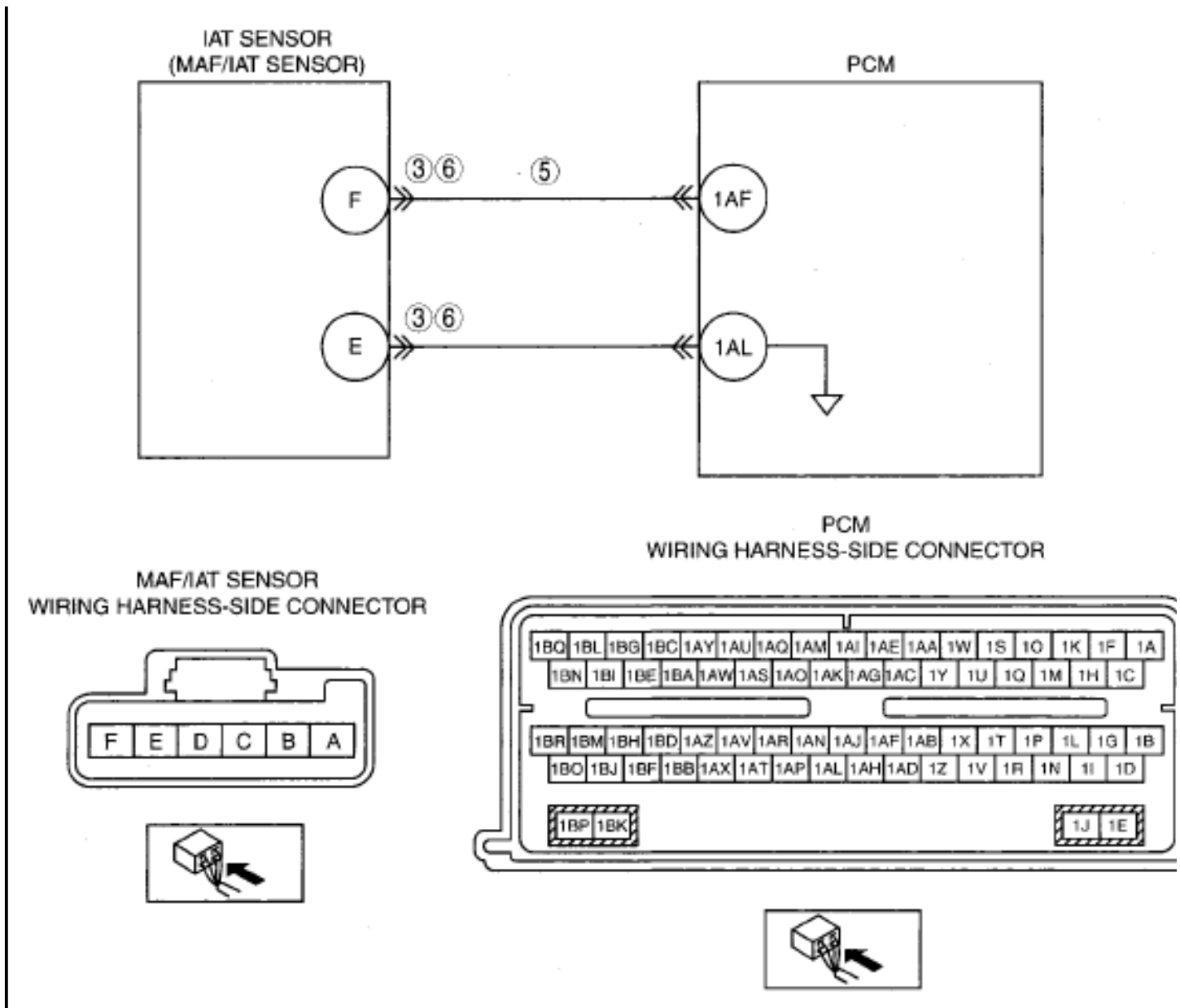

### DIAGNOSTIC PROCEDURE

#### DTC P0112 (MZI-3.5) DIAGNOSTIC PROCEDURE

STEP	INSPECTION		ACTION
1	<b>VERIFY FREEZE FRAME DATA HAS BEEN RECORDED</b>	Yes	Go to the next step.
		No	Record FREEZE FRAME DATA on the repair order, then go to the next step.
2	<b>VERIFY RELATED REPAIR INFORMATION AVAILABILITY</b>	Yes	Perform repair or diagnosis according to the available Service Bulletins.



## 2007 Mazda CX-9 Grand Touring

2007 ENGINE PERFORMANCE On-Board Diagnostic (MZI-3.5) - CX-9

	<ul style="list-style-type: none"> <li>• Verify related Service Bulletins and/or on-line repair information availability.</li> <li>• Is any related Service Bulletins available?</li> </ul>		<ul style="list-style-type: none"> <li>• If the vehicle is not repaired, go to the next step.</li> </ul>
		No	Go to the next step.
3	<b>INSPECT IAT SENSOR TERMINAL</b> <ul style="list-style-type: none"> <li>• Turn the ignition switch off.</li> <li>• Disconnect MAF/IAT sensor connector.</li> <li>• Inspect for bent terminal of MAF/IAT sensor terminals E and F (part-side).</li> <li>• Is there any malfunction?</li> </ul>	Yes	Repair or replace suspected part, then go to Step 6.
		No	Go to the next step.
4	<b>CLASSIFY IAT SENSOR MALFUNCTION OR HARNESS MALFUNCTION</b> <ul style="list-style-type: none"> <li>• Connect M-MDS to DLC-2.</li> <li>• Access IAT PID.</li> <li>• Verify IAT value when disconnecting MAF/IAT sensor connector.</li> <li>• Does IAT value change?</li> </ul>	Yes	Replace MAF/IAT sensor or harness, then go to Step 6.
		No	Go to the next step.
5	<b>INSPECT IAT SIGNAL CIRCUIT FOR SHORT TO GROUND</b> <ul style="list-style-type: none"> <li>• Turn the ignition switch off.</li> <li>• Disconnect PCM connector.</li> <li>• Inspect continuity between MAF/IAT sensor terminal F (wiring harness-side) and body ground.</li> <li>• Is there continuity?</li> </ul>	Yes	Repair or replace suspected part, then go to the next step.
		No	Go to the next step.
6	<b>VERIFY TROUBLESHOOTING OF DTC P0112 HAS BEEN COMPLETED</b> <ul style="list-style-type: none"> <li>• Verify that all disconnected connectors reconnected.</li> <li>• Turn the ignition switch to the ON position (Engine off).</li> <li>• Clear the DTC from the PCM</li> </ul>	Yes	Replace the PCM, then go to the next step. (see <b>PCM REMOVAL/INSTALLATION [MZI-3.5]</b> .)

## 2007 Mazda CX-9 Grand Touring

2007 ENGINE PERFORMANCE On-Board Diagnostic (MZI-3.5) - CX-9

	<p>memory using the M-MDS.</p> <ul style="list-style-type: none"> <li>Start engine and warm it up completely.</li> <li>Is same DTC present?</li> </ul>	No	Go to the next step.
7	<p><b>VERIFY AFTER REPAIR PROCEDURE</b></p> <ul style="list-style-type: none"> <li>Perform the "AFTER REPAIR PROCEDURE".</li> </ul> <p>(See <b>AFTER REPAIR PROCEDURE [MZI-3.5].</b>)</p> <ul style="list-style-type: none"> <li>Are any DTCs present?</li> </ul>	Yes	Go to the applicable DTC inspection. (See <b>DTC TABLE [MZI-3.5].</b> )
		No	Troubleshooting completed.

### DTC P0113 [MZI-3.5]

#### DTC P0113 (MZI-3.5) DETECTION CONDITION AND POSSIBLE CAUSES

<b>DTC P0113</b>	<b>IAT sensor circuit high input</b>
<b>DETECTION CONDITION</b>	<ul style="list-style-type: none"> <li>Indicates the sensor signal is more than the self-test maximum. The IAT sensor maximum is <b>4.6 V or -50 °C {-58 °F}</b>.</li> </ul>
<b>POSSIBLE CAUSE</b>	<ul style="list-style-type: none"> <li>Open circuit between MAF/IAT sensor terminal E and PCM terminal 1AL</li> <li>Open circuit between MAF/IAT sensor terminal F and PCM terminal 1AF</li> <li>Short to power supply between MAF/IAT sensor terminal F and PCM terminal 1/</li> <li>IAT sensor malfunction</li> <li>Connector or terminal malfunction</li> </ul>

## 2007 Mazda CX-9 Grand Touring

2007 ENGINE PERFORMANCE On-Board Diagnostic (MZI-3.5) - CX-9

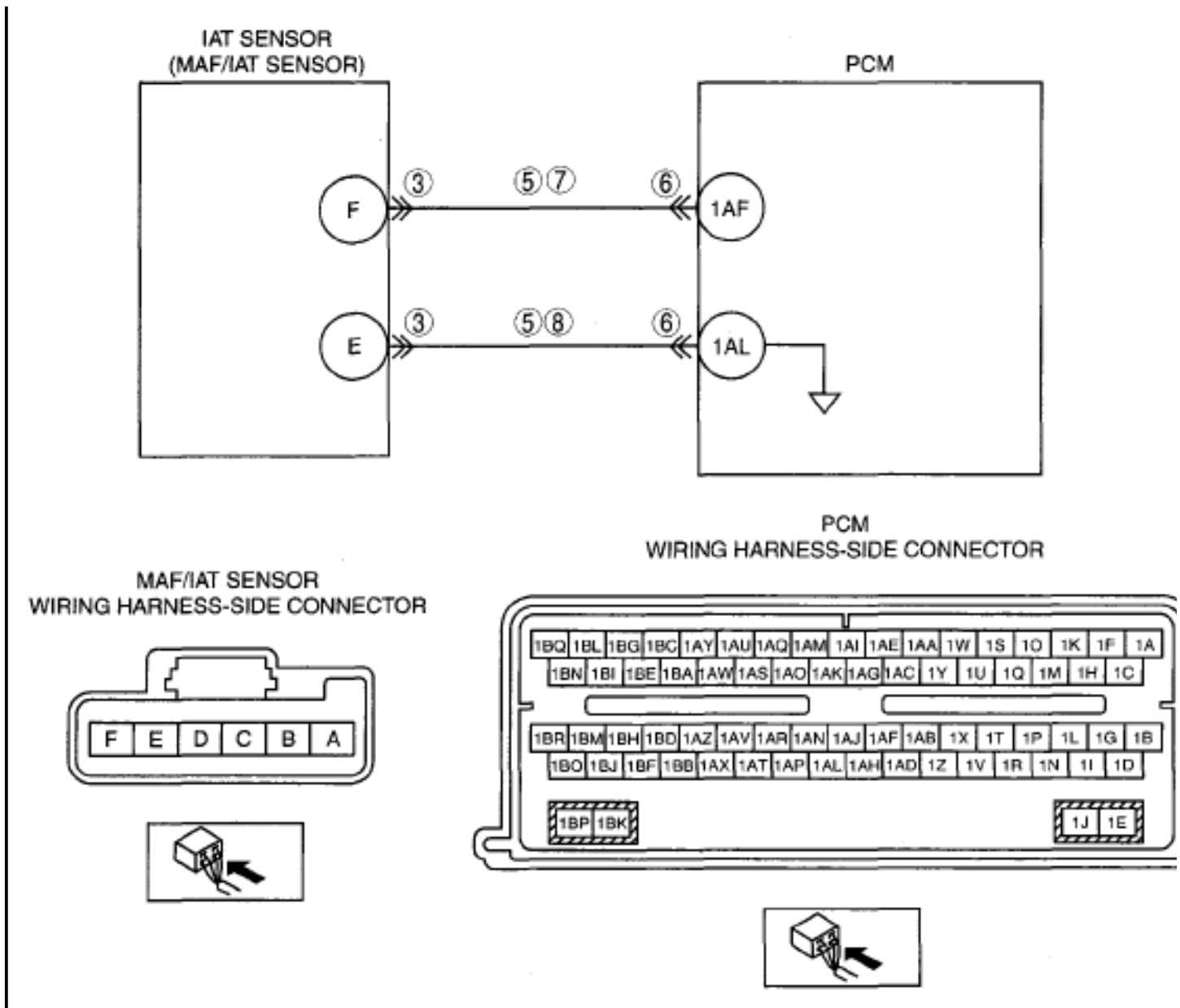

### DIAGNOSTIC PROCEDURE

#### DTC P0113 (MZI-3.5) DETECTION CONDITION AND POSSIBLE CAUSES

STEP	INSPECTION		ACTION
1	<b>VERIFY FREEZE FRAME DATA HAS BEEN RECORDED</b> <ul style="list-style-type: none"> <li>Has FREEZE FRAME DATA been recorded?</li> </ul>	Yes	Go to the next step.
		No	Record FREEZE FRAME DATA on the repair order, then go to the next step.
2	<b>VERIFY RELATED REPAIR INFORMATION AVAILABILITY</b>	Yes	Perform repair or diagnosis according to the available Service Bulletins.

## 2007 Mazda CX-9 Grand Touring

2007 ENGINE PERFORMANCE On-Board Diagnostic (MZI-3.5) - CX-9

	<ul style="list-style-type: none"> <li>• Verify related Service Bulletins and/or on-line repair information availability.</li> <li>• Is any related Service Bulletins available?</li> </ul>		<ul style="list-style-type: none"> <li>• If the vehicle is not repaired, go to the next step.</li> </ul>
		No	Go to the next step.
3	<b>INSPECT IAT SENSOR CONNECTOR FOR POOR CONNECTION</b> <ul style="list-style-type: none"> <li>• Turn the ignition switch off.</li> <li>• Disconnect MAF/IAT sensor connector.</li> <li>• Inspect for poor connection (such as damaged/pulled-out pins, corrosion).</li> <li>• Are there any malfunction?</li> </ul>	Yes	Repair or replace suspected part, then go to Step 9.
		No	Go to the next step.
4	<b>CLASSIFY IAT SENSOR MALFUNCTION OR HARNESS MALFUNCTION</b> <ul style="list-style-type: none"> <li>• Disconnect the MAF/IAT sensor connector.</li> <li>• Turn the ignition switch to the ON position (Engine off).</li> <li>• Measure voltage between MAF/IAT sensor terminal F (wiring harness-side) and body ground.</li> <li>• Is voltage <b>4.5-5.5 V</b>?</li> </ul>	Yes	Inspect the IAT sensor. (see <b><u>INTAKE AIR TEMPERATURE (IAT) SENSOR INSPECTION [MZI-3.5]</u></b> .) Replace if necessary, then go to Step 9.
		No	Go to the next step.
5	<b>INSPECT IAT SENSOR SIGNAL CIRCUIT FOR SHORT TO POWER SUPPLY</b> <ul style="list-style-type: none"> <li>• Turn the ignition switch to the ON position (Engine off).</li> <li>• Measure voltage between MAF/IAT sensor terminal F (wiring harness-side) and body ground.</li> <li>• Is voltage <b>B+</b> ?</li> </ul>	Yes	Repair or replace suspected part, then go to Step 9.
		No	Go to the next step.
6	<b>INSPECT PCM CONNECTOR FOR POOR CONNECTION</b> <ul style="list-style-type: none"> <li>• Turn the ignition switch off.</li> </ul>	Yes	Repair or replace suspected part, then go to Step 9.

## 2007 Mazda CX-9 Grand Touring

2007 ENGINE PERFORMANCE On-Board Diagnostic (MZI-3.5) - CX-9

	<ul style="list-style-type: none"> <li>• Disconnect PCM connector.</li> <li>• Inspect for poor connection (such as damaged/pulled-out pins, corrosion).</li> <li>• Are there any malfunction?</li> </ul>	No	Go to the next step.
7	<b>INSPECT IAT SENSOR SIGNAL CIRCUIT FOR OPEN CIRCUIT</b> <ul style="list-style-type: none"> <li>• Inspect continuity between MAF/IAT sensor terminal F (wiring harness-side) and PCM terminal 1AF (wiring harness-side).</li> <li>• Is there continuity?</li> </ul>	Yes	Go to the next step.
		No	Repair or replace suspected part, then go to Step 9.
8	<b>INSPECT IAT SENSOR GROUND CIRCUIT FOR OPEN CIRCUIT</b> <ul style="list-style-type: none"> <li>• Inspect continuity between MAF/IAT sensor terminal E (wiring harness-side) and PCM terminal 1AL (wiring harness-side).</li> <li>• Is there continuity?</li> </ul>	Yes	Go to the next step.
		No	Repair or replace suspected part, then go to the next step.
9	<b>VERIFY TROUBLESHOOTING OF DTC P0113 HAS BEEN COMPLETED</b> <ul style="list-style-type: none"> <li>• Verify that all disconnected connectors reconnected.</li> <li>• Turn the ignition switch to the ON position (Engine off).</li> <li>• Clear the DTC from the PCM memory using the M-MDS.</li> <li>• Start engine and warm it up completely.</li> <li>• Is same DTC present?</li> </ul>	Yes	Replace the PCM, then go to the next step. (see <b><u>PCM REMOVAL/INSTALLATION [MZI-3.5]</u></b> .)
		No	Go to the next step.
10	<b>VERIFY AFTER REPAIR PROCEDURE</b> <ul style="list-style-type: none"> <li>• Perform the "AFTER REPAIR PROCEDURE".</li> </ul> <p>(See <b><u>AFTER REPAIR PROCEDURE [MZI-3.5]</u></b>.)</p>	Yes	Go to the applicable DTC inspection. (See <b><u>DTC TABLE [MZI-3.5]</u></b> .)
		No	Troubleshooting completed.

## 2007 Mazda CX-9 Grand Touring

2007 ENGINE PERFORMANCE On-Board Diagnostic (MZI-3.5) - CX-9

- |   |  |
|---|--|
| <ul style="list-style-type: none"> <li>• Are any DTCs present?</li> </ul> |  |
|---|--|

### DTC P0114 [MZI-3.5]

#### DTC P0114 (MZI-3.5) DETECTION CONDITION AND POSSIBLE CAUSES

<b>DTC P0114</b>	<b>IAT sensor Intermittent/erratic</b>
<b>DETECTION CONDITION</b>	<ul style="list-style-type: none"> <li>• Indicates the sensor signal was intermittent during the CCM.</li> </ul>
<b>POSSIBLE CAUSE</b>	<ul style="list-style-type: none"> <li>• IAT sensor malfunction</li> <li>• Harness malfunction</li> <li>• Connector or terminal malfunction</li> </ul>

#### DIAGNOSTIC PROCEDURE

#### DTC P0114 (MZI-3.5) DETECTION CONDITION AND POSSIBLE CAUSES

STEP	INSPECTION		ACTION
1	<b>VERIFY FREEZE FRAME DATA HAS BEEN RECORDED</b> <ul style="list-style-type: none"> <li>• Has FREEZE FRAME DATA been recorded?</li> </ul>	Yes	Go to the next step.
		No	Record FREEZE FRAME DATA on the repair order, then go to the next step.
2	<b>VERIFY RELATED REPAIR INFORMATION AVAILABILITY</b> <ul style="list-style-type: none"> <li>• Verify related Service Bulletins and/or on-line repair information availability.</li> <li>• Is any related Service Bulletins available?</li> </ul>	Yes	Perform repair or diagnosis according to the available Service Bulletins. <ul style="list-style-type: none"> <li>• If the vehicle is not repaired, go to the next step.</li> </ul>
		No	Go to the next step.
3	<b>INSPECT CONNECTOR FOR POOR CONNECTION</b> <ul style="list-style-type: none"> <li>• Turn the ignition switch off.</li> <li>• Disconnect PCM connector and IAT sensor connectors.</li> <li>• Inspect for poor connection (such as damaged, pulled-out pins, and corrosion).</li> <li>• Is there any malfunction?</li> </ul>	Yes	Go to the next step.
		No	Repair or replace suspected part, then go to Step 6.
4	<b>INTERMITTENT INSPECTION</b> <ul style="list-style-type: none"> <li>• Turn the ignition switch to the ON position (Engine off).</li> </ul>	Yes	Inspect the IAT sensor. (see <b><u>INTAKE AIR TEMPERATURE (IAT) SENSOR INSPECTION [MZI-3.5].</u></b> )

## 2007 Mazda CX-9 Grand Touring

2007 ENGINE PERFORMANCE On-Board Diagnostic (MZI-3.5) - CX-9

	<ul style="list-style-type: none"> <li>• Access the PCM and monitor the IAT PID.</li> <li>• While observing the PID, perform the following:                             <ul style="list-style-type: none"> <li>○ Tap on the sensor to simulate road shock</li> <li>○ Wiggle the sensor connector</li> </ul> </li> <li>• Is there a large change in the voltage reading?</li> </ul>		Replace if necessary, then go to Step 6.
		No	Go to the next step.
5	<b>INSPECT ELECTRONIC ENGINE CONTROL WIRING HARNESS</b> <ul style="list-style-type: none"> <li>• Access the PCM and monitor the IAT PID.</li> <li>• While observing the PID, wiggle, shake, and bend small sections of the wiring harness while working from the sensor to the PCM.</li> <li>• Is there a large change in the voltage reading?</li> </ul>	Yes	Repair if necessary, then go to Step 6.
		No	Go to the next step.
6	<b>VERIFY TROUBLESHOOTING OF DTC P0114 HAS BEEN COMPLETED</b> <ul style="list-style-type: none"> <li>• Verify that all disconnected connectors reconnected.</li> <li>• Turn the ignition switch to the ON position (Engine off).</li> <li>• Clear the DTC from the PCM memory using the M-MDS.</li> <li>• Start the engine and run it at idle.</li> <li>• Retrieve DTCs using the M-MDS.</li> <li>• Is the PENDING CODE for this DTC present?</li> </ul>	Yes	Replace the PCM, then go to the next step. (see <b><u>PCM REMOVAL/INSTALLATION [MZI-3.5]</u></b> .)
		No	Go to the next step.
7	<b>VERIFY AFTER REPAIR PROCEDURE</b> <ul style="list-style-type: none"> <li>• Perform the "AFTER REPAIR PROCEDURE".</li> </ul> <p>(See <b><u>AFTER REPAIR PROCEDURE [MZI-3.5]</u></b>.)</p>	Yes	Go to the applicable DTC inspection. (See <b><u>DTC TABLE [MZI-3.5]</u></b> .)
		No	Troubleshooting completed.

## 2007 Mazda CX-9 Grand Touring

2007 ENGINE PERFORMANCE On-Board Diagnostic (MZI-3.5) - CX-9

- |   |  |
|---|--|
| <ul style="list-style-type: none"> <li>• Are any DTCs present?</li> </ul> |  |
|---|--|

### DTC P0116 [MZI-3.5]

#### DTC P0116 (MZI-3.5) DETECTION CONDITION AND POSSIBLE CAUSES

DTC P0116	CHT sensor circuit range/performance
<b>DETECTION CONDITION</b>	<ul style="list-style-type: none"> <li>• Indicates the engine coolant temperature logic test has failed. This DTC indicates that the CHT value is higher than the calibrated value and could prevent 1 or more OBD monitors from completing.</li> </ul> <p>The PCM runs this logic after an engine off and a calibrated soak period (typically 6 hours).</p> <p>This soak period allows the IAT and the CHT to stabilize and not differ by more than a calibrated value.</p> <p>DTC P0116 is set when all of the following conditions are met:</p> <ul style="list-style-type: none"> <li>○ The CHT at engine start exceeds the IAT at engine start by more than a calibrated value, typically <b>17 °C {30 °F}</b>.</li> <li>○ The CHT exceeds a calibrated value, typically <b>107 °C {225 °F}</b>.</li> <li>○ The fuel system, heated oxygen and misfire monitors have not completed.</li> <li>○ The calibrated time to set DTC P0116 has expired.</li> </ul>
<b>POSSIBLE CAUSE</b>	<ul style="list-style-type: none"> <li>• Cooling system malfunction</li> <li>• CHT sensor malfunction</li> </ul>

#### DIAGNOSTIC PROCEDURE

##### DTC P0116 (MZI-3.5) DIAGNOSTIC PROCEDURE

STEP	INSPECTION		ACTION
1	<b>VERIFY FREEZE FRAME DATA HAS BEEN RECORDED</b>	Yes	Go to the next step.
	<ul style="list-style-type: none"> <li>• Has FREEZE FRAME DATA been recorded?</li> </ul>	No	Record FREEZE FRAME DATA on the repair order, then go to the next step.
2	<b>VERIFY RELATED REPAIR INFORMATION AVAILABILITY</b>	Yes	Perform repair or diagnosis according to the available Service Bulletins. If the vehicle is not repaired, go to next step.
	<ul style="list-style-type: none"> <li>• Verify related Service Bulletins and/or on-line repair information availability.</li> <li>• Is any related Service Bulletins</li> </ul>	No	Go to the next step.



## 2007 Mazda CX-9 Grand Touring

2007 ENGINE PERFORMANCE On-Board Diagnostic (MZI-3.5) - CX-9

	available?		
3	<b>VERIFY RELATED PENDING CODE OR STORED DTC</b> <ul style="list-style-type: none"> <li>• Verify the related PENDING CODE or stored DTCs.</li> <li>• Are other DTCs present?</li> </ul>	Yes	Go to appropriate DTC inspection. (See <b><u>DTC TABLE [MZI-3.5].</u></b> )
		No	Go to the next step.
4	<b>INSPECT CHT SENSOR</b> <ul style="list-style-type: none"> <li>• Inspect the CHT sensor.</li> </ul> <p>(see <b><u>CYLINDER HEAD TEMPERATURE (CHT) SENSOR INSPECTION [MZI-3.5].</u></b>)</p> <ul style="list-style-type: none"> <li>• Are there any malfunction?</li> </ul>	Yes	Replace the CHT sensor, then go to the next step.
		No	Go to the next step.
5	<b>VERIFY TROUBLESHOOTING OF DTC P0116 HAS BEEN COMPLETED</b> <ul style="list-style-type: none"> <li>• Make sure to reconnect all disconnected connectors.</li> <li>• Clear DTC from memory using M-MDS.</li> <li>• Start the engine.</li> <li>• Perform the "KOE0/KOER self-test" (See <b><u>KOE0/KOER SELF TEST [MZI-3.5].</u></b>)</li> <li>• Is same DTC present?</li> </ul>	Yes	Replace the PCM, then go to next step. (see <b><u>PCM REMOVAL/INSTALLATION [MZI-3.5].</u></b> )
		No	Go to the next step.
6	<b>VERIFY AFTER REPAIR PROCEDURE</b> <ul style="list-style-type: none"> <li>• Perform the "AFTER REPAIR PROCEDURE".</li> </ul> <p>(See <b><u>AFTER REPAIR PROCEDURE [MZI-3.5].</u></b>)</p> <ul style="list-style-type: none"> <li>• Are any DTCs present?</li> </ul>	Yes	Go to the applicable DTC inspection. (See <b><u>DTC TABLE [MZI-3.5].</u></b> )
		No	Troubleshooting completed.

### DTC P0119 [MZI-3.5]

#### DTC P0119 (MZI-3.5) DETECTION CONDITION AND POSSIBLE CAUSES

--	--

## 2007 Mazda CX-9 Grand Touring

2007 ENGINE PERFORMANCE On-Board Diagnostic (MZI-3.5) - CX-9

<b>DTC P0119</b>	<b>CHT sensor circuit intermittent/erratic</b>
<b>DETECTION CONDITION</b>	<ul style="list-style-type: none"> <li>Indicates the ECT circuit became intermittently open or shorted while the engine was running.</li> </ul>
<b>POSSIBLE CAUSE</b>	<ul style="list-style-type: none"> <li>Harness malfunction</li> <li>Connector or terminal malfunction</li> <li>Low engine coolant</li> <li>CHT sensor malfunction</li> </ul>

### DIAGNOSTIC PROCEDURE

#### DTC P0119 (MZI-3.5) DIAGNOSTIC PROCEDURE

STEP	INSPECTION		ACTION
1	<b>VERIFY FREEZE FRAME DATA HAS BEEN RECORDED</b> <ul style="list-style-type: none"> <li>Has FREEZE FRAME DATA been recorded?</li> </ul>	Yes	Go to the next step.
		No	Record FREEZE FRAME DATA on the repair order, then go to the next step.
2	<b>VERIFY RELATED REPAIR INFORMATION AVAILABILITY</b> <ul style="list-style-type: none"> <li>Verify related Service Bulletins availability.</li> <li>Is any related Service Bulletins available?</li> </ul>	Yes	Perform repair or diagnosis according to available Service Bulletins. <ul style="list-style-type: none"> <li>If vehicle is not repaired, go to the next step.</li> </ul>
		No	Go to the next step.
3	<b>INSPECT CONNECTOR FOR POOR CONNECTION</b> <ul style="list-style-type: none"> <li>Turn the ignition switch off.</li> <li>Disconnect PCM connector and CHT sensor connectors.</li> <li>Inspect for poor connection (such as damaged, pulled-out pins, and corrosion).</li> <li>Is there any malfunction?</li> </ul>	Yes	Repair or replace suspected part, then go to Step 7.
		No	Go to the next step.
4	<b>INTERMITTENT INSPECTION</b> <ul style="list-style-type: none"> <li>Turn the ignition switch to the ON position (Engine off).</li> <li>Access the PCM and monitor the CHT PID.</li> <li>While observing the PID, perform the following:</li> </ul>	Yes	Inspect the CHT sensor. (see <b>CYLINDER HEAD TEMPERATURE (CHT) SENSOR INSPECTION [MZI-3.5].</b> ) Replace if necessary, then go to Step 7.

## 2007 Mazda CX-9 Grand Touring

2007 ENGINE PERFORMANCE On-Board Diagnostic (MZI-3.5) - CX-9

	<ul style="list-style-type: none"> <li>○ Tap on the sensor to simulate road shock</li> <li>○ Wiggle the sensor connector</li> <li>● Is there a large change in the voltage reading?</li> </ul>	No	Go to the next step.
5	<b>INSPECT ELECTRONIC ENGINE CONTROL (EEC) WIRING HARNESS</b> <ul style="list-style-type: none"> <li>● Access the PCM and monitor the CHT PID.</li> <li>● While observing the PID, wiggle, shake, and bend small sections of the wiring harness while working from the sensor to the PCM.</li> <li>● Is there a large change in the voltage reading?</li> </ul>	Yes	Repair if necessary, then go to Step 7.
		No	Go to the next step.
6	<b>INSPECT FOR CORRECT PCM OPERATION</b> <ul style="list-style-type: none"> <li>● Disconnect the PCM connector.</li> <li>● Visually inspect for:                             <ul style="list-style-type: none"> <li>○ Pushed out pins</li> <li>○ Corrosion</li> </ul> </li> <li>● Connect all the PCM connectors and verify that they seat correctly.</li> <li>● Retrieve DTCs using the M-MDS.</li> <li>● Is the PENDING CODE for this DTC present?</li> </ul>	Yes	Go to the next step.
		No	The system is correctly. Go to the next step.
7	<b>VERIFY TROUBLESHOOTING OF DTC P0119 HAS BEEN COMPLETED</b> <ul style="list-style-type: none"> <li>● Make sure to reconnect all disconnected connectors.</li> <li>● Clear the DTC from memory using M-MDS.</li> <li>● Start the engine.</li> <li>● Perform the "KOEO/KOER self-test"</li> </ul> <p>(See <b><u>KOEO/KOER SELF TEST [MZI-3.5].</u></b>)</p>	Yes	Replace the PCM, then go to the next step. (see <b><u>PCM REMOVAL/INSTALLATION [MZI-3.5]</u></b> .)
		No	Go to the next step.

## 2007 Mazda CX-9 Grand Touring

2007 ENGINE PERFORMANCE On-Board Diagnostic (MZI-3.5) - CX-9

	<ul style="list-style-type: none"> <li>• Is same DTC present?</li> </ul>		
8	<p><b>VERIFY AFTER REPAIR PROCEDURE</b></p> <ul style="list-style-type: none"> <li>• Perform the "AFTER REPAIR PROCEDURE".</li> </ul> <p>(See <b><u>AFTER REPAIR PROCEDURE [MZI-3.5].</u></b>)</p> <ul style="list-style-type: none"> <li>• Are any DTCs present?</li> </ul>	Yes	Go to the applicable DTC inspection. (See <b><u>DTC TABLE [MZI-3.5].</u></b> )
		No	Troubleshooting completed.

### DTC P0122 [MZI-3.5]

#### DTC P0122 (MZI-3.5) DETECTION CONDITION AND POSSIBLE CAUSES

<b>DTC P0122</b>	<b>TP sensor No.1 circuit low input</b>
<b>DETECTION CONDITION</b>	<ul style="list-style-type: none"> <li>• The TP sensor No. 1 circuit was flagged as a concern by the PCM indicating a low voltage or open circuit.</li> </ul>
<b>POSSIBLE CAUSE</b>	<ul style="list-style-type: none"> <li>• TP sensor No. 1 malfunction</li> <li>• Connector or terminal malfunction</li> <li>• Open circuit between throttle body terminal F and PCM terminal 2Z</li> <li>• Short to ground circuit between throttle body terminal F and PCM terminal 2Z</li> <li>• Open circuit between throttle body terminal E and PCM terminal 2AH</li> </ul>

## 2007 Mazda CX-9 Grand Touring

2007 ENGINE PERFORMANCE On-Board Diagnostic (MZI-3.5) - CX-9

TP SENSOR NO.1 (THROTTLE BODY)

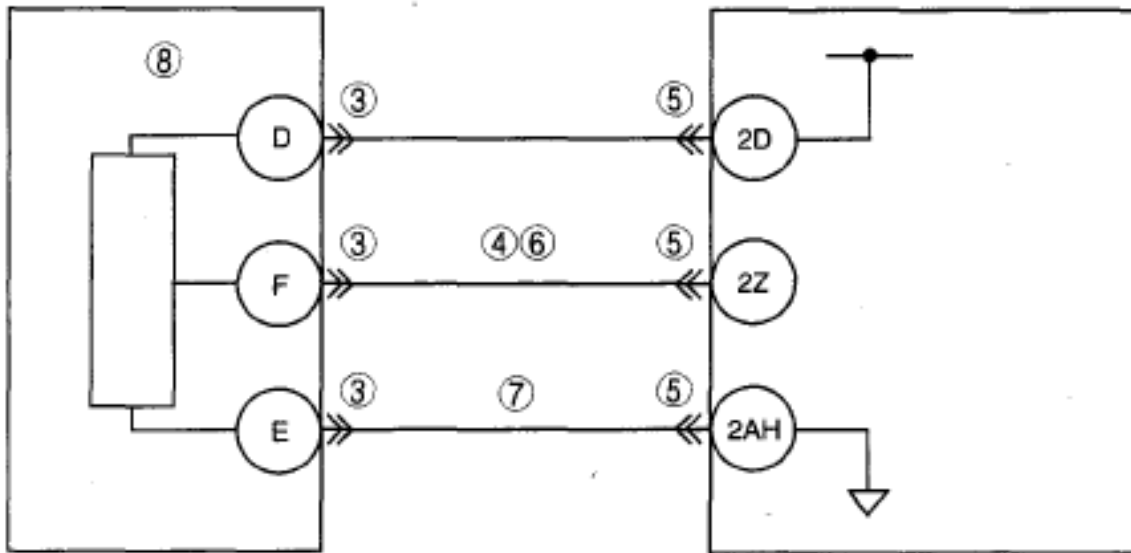

PCM  
WIRING HARNESS-SIDE CONNECTOR

THROTTLE BODY  
WIRING HARNESS-SIDE CONNECTOR

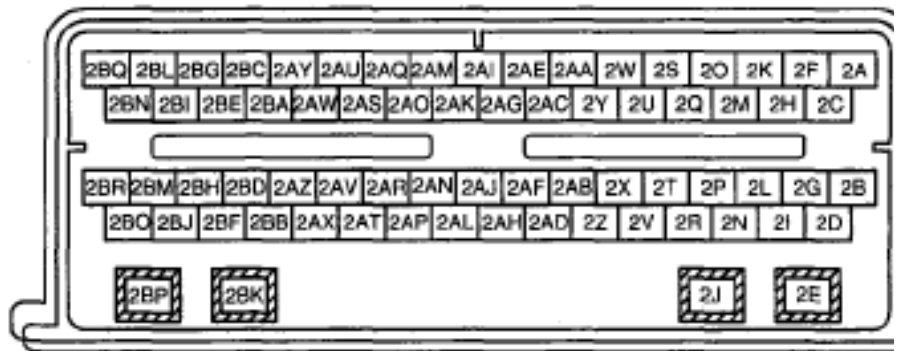
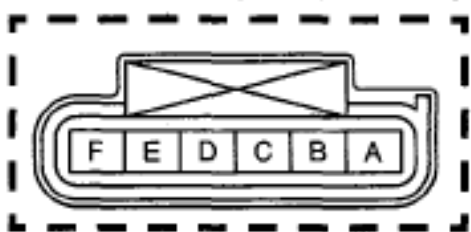

### DIAGNOSTIC PROCEDURE

#### DTC P0122 (MZI-3.5) DIAGNOSTIC PROCEDURE

STEP	INSPECTION		ACTION
1	<b>VERIFY FREEZE FRAME DATA HAS BEEN RECORDED</b>	Yes	Go to the next step.
		No	Record FREEZE FRAME DATA on the repair order, then go to the next step.
2	<b>VERIFY RELATED REPAIR</b>	Yes	Perform repair or diagnosis according to

## 2007 Mazda CX-9 Grand Touring

2007 ENGINE PERFORMANCE On-Board Diagnostic (MZI-3.5) - CX-9

	<p><b>INFORMATION AVAILABILITY</b></p> <ul style="list-style-type: none"> <li>• Verify related Service Bulletins and/or on-line repair information availability.</li> <li>• Is any related Service Bulletins available?</li> </ul>		<p>the available Service Bulletins.</p> <ul style="list-style-type: none"> <li>• If the vehicle is not repaired, go to the next step.</li> </ul>
		No	Go to the next step.
3	<p><b>INSPECT TP SENSOR CONNECTOR FOR POOR CONNECTION</b></p> <ul style="list-style-type: none"> <li>• Turn the ignition switch off.</li> <li>• Disconnect the throttle body connector.</li> <li>• Inspect for poor connection (such as damaged/pulled-out pins, corrosion).</li> <li>• Are there any malfunction?</li> </ul>	Yes	Repair or replace suspected part, then go to Step 9.
		No	Go to the next step.
4	<p><b>INSPECT TP SENSOR CIRCUIT FOR SHORT TO GROUND</b></p> <ul style="list-style-type: none"> <li>• Turn the ignition switch to the ON position (Engine off).</li> <li>• Inspect for continuity between TP sensor terminal F (wiring harness-side) and body ground</li> <li>• Is there continuity?</li> </ul>	Yes	Repair or replace suspected part, then go to Step 9.
		No	Go to the next step.
5	<p><b>INSPECT PCM CONNECTOR FOR POOR CONNECTION</b></p> <ul style="list-style-type: none"> <li>• Turn the ignition switch off.</li> <li>• Disconnect the PCM connector.</li> <li>• Inspect for poor connection (such as damaged/pulled-out pins, corrosion).</li> <li>• Are there any malfunction?</li> </ul>	Yes	Repair or replace suspected part, then go to Step 9.
		No	Go to the next step.
6	<p><b>INSPECT TP SIGNAL CIRCUIT FOR OPEN CIRCUIT</b></p> <ul style="list-style-type: none"> <li>• Inspect for continuity between throttle body connector terminal F (wiring harness-side) and PCM terminal 2Z (wiring harness-side).</li> <li>• Is there continuity?</li> </ul>	Yes	Go to the next step.
		No	Repair or replace suspected part, then go to Step 9.

## 2007 Mazda CX-9 Grand Touring

2007 ENGINE PERFORMANCE On-Board Diagnostic (MZI-3.5) - CX-9

7	<p><b>INSPECT TP GROUND CIRCUIT FOR OPEN CIRCUIT</b></p> <ul style="list-style-type: none"> <li>• Turn the ignition switch off.</li> <li>• Verify the continuity between TP sensor terminal E (wiring harness-side) and PCM terminal 2AH (wiring harness-side).</li> <li>• Is the continuity?</li> </ul>	Yes	Go to the next step.
		No	Repair or replace suspected part, then go to Step 9.
8	<p><b>INSPECT TP SENSOR NO.1</b></p> <ul style="list-style-type: none"> <li>• Inspect the TP sensor No.1.</li> </ul> <p>(see <b><u>THROTTLE POSITION (TP) SENSOR INSPECTION [MZI-3.5]</u></b>.)</p> <ul style="list-style-type: none"> <li>• Is there any malfunction?</li> </ul>	Yes	Replace the throttle body, then go to the next step.
		No	Go to the next step.
9	<p><b>VERIFY TROUBLESHOOTING OF DTC P0122 HAS BEEN COMPLETED</b></p> <ul style="list-style-type: none"> <li>• Make sure to reconnect all disconnected connectors.</li> <li>• Clear the DTC from the PCM memory using the M-MDS.</li> <li>• Start the engine.</li> <li>• Perform the "KOEO/KOER self-test".</li> </ul> <p>(See <b><u>KOEO/KOER SELF TEST [MZI-3.5]</u></b>.)</p> <ul style="list-style-type: none"> <li>• Is same DTC present?</li> </ul>	Yes	Replace the PCM, then go to the next step. (see <b><u>PCM REMOVAL/INSTALLATION [MZI-3.5]</u></b> .)
		No	Go to the next step.
10	<p><b>VERIFY AFTER REPAIR PROCEDURE</b></p> <ul style="list-style-type: none"> <li>• Perform the "AFTER REPAIR PROCEDURE".</li> </ul> <p>(See <b><u>AFTER REPAIR PROCEDURE [MZI-3.5]</u></b>.)</p> <ul style="list-style-type: none"> <li>• Are any DTCs present?</li> </ul>	Yes	Go to the applicable DTC inspection. (See <b><u>DTC TABLE [MZI-3.5]</u></b> .)
		No	Troubleshooting completed.

# 2007 Mazda CX-9 Grand Touring

2007 ENGINE PERFORMANCE On-Board Diagnostic (MZI-3.5) - CX-9

## DTC P0123 [MZI-3.5]

### DTC P0123 (MZI-3.5) DETECTION CONDITION AND POSSIBLE CAUSES

<b>DTC P0123</b>	<b>TP sensor No.1 circuit high input</b>
<b>DETECTION CONDITION</b>	<ul style="list-style-type: none"> <li>The TP sensor No.1 circuit was flagged as a concern by the PCM indicating a high voltage.</li> </ul>
<b>POSSIBLE CAUSE</b>	<ul style="list-style-type: none"> <li>TP sensor No.1 malfunction</li> <li>Connector or terminal malfunction</li> <li>Short to constant voltage supply circuit between throttle body terminal F and PCM terminal 2Z</li> <li>TP sensor signal circuits are shorted each other</li> </ul>

TP SENSOR NO.1 (THROTTLE BODY)

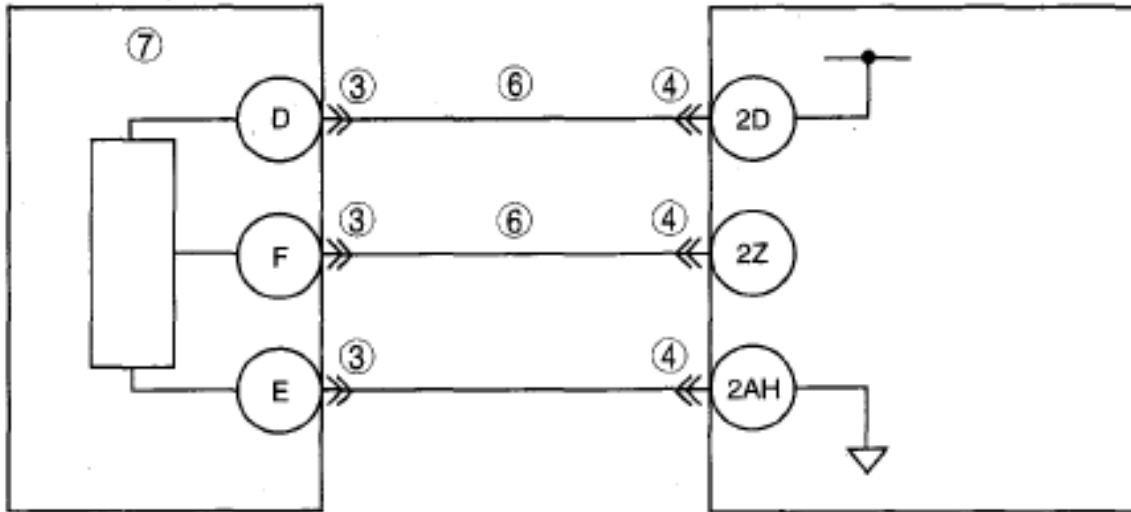

PCM WIRING HARNESS-SIDE CONNECTOR

THROTTLE BODY WIRING HARNESS-SIDE CONNECTOR

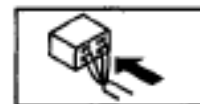
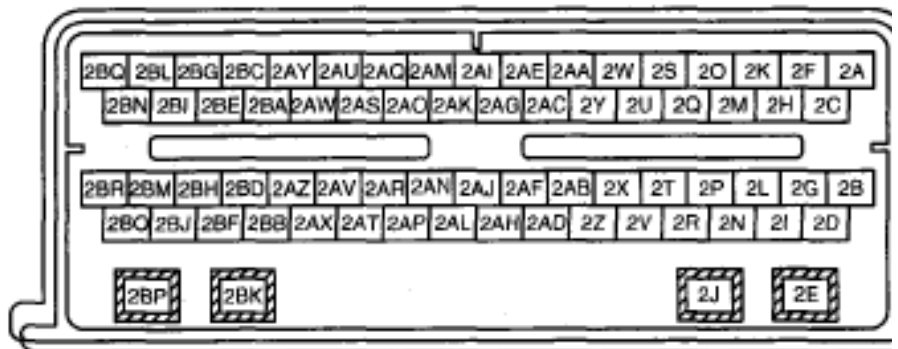
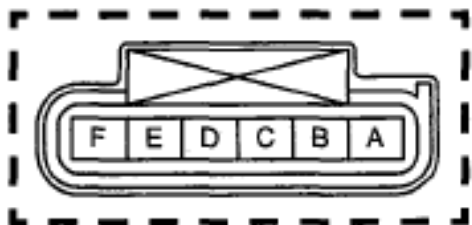



## 2007 Mazda CX-9 Grand Touring

2007 ENGINE PERFORMANCE On-Board Diagnostic (MZI-3.5) - CX-9

### DIAGNOSTIC PROCEDURE

#### DTC P0123 (MZI-3.5) DIAGNOSTIC PROCEDURE

STEP	INSPECTION	ACTION	
1	<b>VERIFY FREEZE FRAME DATA HAS BEEN RECORDED</b> <ul style="list-style-type: none"> <li>• Has FREEZE FRAME DATA been recorded?</li> </ul>	Yes	Go to the next step.
		No	Record FREEZE FRAME DATA on the repair order, then go to the next step.
2	<b>VERIFY RELATED REPAIR INFORMATION AVAILABILITY</b> <ul style="list-style-type: none"> <li>• Verify related Service Bulletins and/or on-line repair information availability.</li> <li>• Is any related Service Bulletins available?</li> </ul>	Yes	Perform repair or diagnosis according to the available Service Bulletins. <ul style="list-style-type: none"> <li>• If the vehicle is not repaired, go to the next step.</li> </ul>
		No	Go to the next step.
3	<b>INSPECT TP SENSOR CONNECTOR FOR POOR CONNECTION</b> <ul style="list-style-type: none"> <li>• Turn the ignition switch off.</li> <li>• Disconnect the throttle body connector.</li> <li>• Inspect for poor connection (such as damaged/pulled-out pins, corrosion).</li> <li>• Are there any malfunction?</li> </ul>	Yes	Repair or replace suspected part, then go to Step 8.
		No	Go to the next step.
4	<b>INSPECT PCM CONNECTOR FOR POOR CONNECTION</b> <ul style="list-style-type: none"> <li>• Turn the ignition switch off.</li> <li>• Disconnect the PCM connector.</li> <li>• Inspect for poor connection (such as damaged/pulled-out pins, corrosion).</li> <li>• Are there any malfunction?</li> </ul>	Yes	Repair or replace suspected part, then go to Step 8.
		No	Go to the next step.
5	<b>INSPECT TP SIGNAL CIRCUIT FOR SHORT TO POWER SUPPLY</b> <ul style="list-style-type: none"> <li>• Turn the ignition switch to the ON position (Engine off).</li> <li>• Measure the voltage between Throttle body connector terminal</li> </ul>	Yes	Repair or replace suspected part, then go to Step 8.

## 2007 Mazda CX-9 Grand Touring

2007 ENGINE PERFORMANCE On-Board Diagnostic (MZI-3.5) - CX-9

	<p>F (wiring harness-side) and body ground.</p> <ul style="list-style-type: none"> <li>• Is the voltage B+?</li> </ul>	No	Go to the next step.
6	<p><b>INSPECT TP SENSOR SIGNAL CIRCUITS FOR SHORT EACH OTHER</b></p> <ul style="list-style-type: none"> <li>• Disconnect the TP sensor and PCM connector.</li> <li>• Measure resistance between Throttle body connector terminal D and F</li> <li>• Is the resistance more than 10 kilohms?</li> </ul>	Yes	Go to the next step.
		No	Repair or replace suspected part, then go to Step 8.
7	<p><b>INSPECT TP SENSOR NO.1</b></p> <ul style="list-style-type: none"> <li>• Inspect the TP sensor No. 1.</li> </ul> <p>(see <b><u>THROTTLE POSITION (TP) SENSOR INSPECTION [MZI-3.5].</u></b>)</p> <ul style="list-style-type: none"> <li>• Are there any malfunction?</li> </ul>	Yes	Replace the throttle body, then go to the next step.
		No	Go to the next step.
8	<p><b>VERIFY TROUBLESHOOTING OF DTC P0123 HAS BEEN COMPLETED</b></p> <ul style="list-style-type: none"> <li>• Make sure to reconnect all disconnected connectors.</li> <li>• Clear the DTC from the PCM memory using the M-MDS.</li> <li>• Start the engine.</li> <li>• Perform the "KOEO/KOER self-test".</li> </ul> <p>(See <b><u>KOEO/KOER SELF TEST [MZI-3.5].</u></b>)</p> <ul style="list-style-type: none"> <li>• Is same DTC present?</li> </ul>	Yes	Replace the PCM, then go to the next step. (see <b><u>PCM REMOVAL/INSTALLATION [MZI-3.5].</u></b> )
		No	Go to the next step.
9	<p><b>VERIFY AFTER REPAIR PROCEDURE</b></p> <ul style="list-style-type: none"> <li>• Perform the "AFTER REPAIR PROCEDURE".</li> </ul>	Yes	Go to the applicable DTC inspection. (See <b><u>DTC TABLE [MZI-3.5].</u></b> )

## 2007 Mazda CX-9 Grand Touring

2007 ENGINE PERFORMANCE On-Board Diagnostic (MZI-3.5) - CX-9

(See <b><u>AFTER REPAIR PROCEDURE [MZI-3.5].</u></b> )  • Are any DTCs present?	No	Troubleshooting completed.
---	----	----------------------------

### DTC P0128 [MZI-3.5]

#### DTC P0128 (MZI-3.5) DETECTION CONDITION AND POSSIBLE CAUSES

<b>DTC P0128</b>	<b>Coolant thermostat (coolant temp below thermostat regulating temperature)</b>
<b>DETECTION CONDITION</b>	<ul style="list-style-type: none"> <li>• P0128 Indicates that the thermostat monitor has not achieved the required engine operating temperature within a specified amount of time after starting the engine.</li> </ul>
<b>POSSIBLE CAUSE</b>	<ul style="list-style-type: none"> <li>• Insufficient warm up time</li> <li>• Low engine coolant level</li> <li>• Leaking or stuck open thermostat</li> <li>• Inoperative cylinder head temperature (CHT) sensor</li> </ul>

#### DIAGNOSTIC PROCEDURE

#### DTC P0128 (MZI-3.5) DIAGNOSTIC PROCEDURE

STEP	INSPECTION		ACTION
1	<b>VERIFY FREEZE FRAME DATA HAS BEEN RECORDED</b>  <ul style="list-style-type: none"> <li>• Has FREEZE FRAME DATA been recorded?</li> </ul>	Yes	Go to the next step.
		No	Record FREEZE FRAME DATA on the repair order, then go to the next step.
2	<b>VERIFY RELATED REPAIR INFORMATION AVAILABILITY</b>  <ul style="list-style-type: none"> <li>• Verify related Service Bulletins and/or on-line repair information availability.</li> <li>• Is any related Service Bulletins available?</li> </ul>	Yes	Perform repair or diagnosis according to the available Service Bulletins.  <ul style="list-style-type: none"> <li>• If the vehicle is not repaired, go to the next step.</li> </ul>
		No	Go to the next step.
3	<b>INSPECT ENGINE COOLANT LEVEL</b>  <b>WARNING:</b> <ul style="list-style-type: none"> <li>• Never remove the cooling system cap or loosen the radiator drain plug while the engine is running, or when the engine and radiator are hot.</li> </ul>	Yes	Go to the next step.
		No	Inspect for a loss of engine coolant. Repair if necessary. (see <b><u>ENGINE COOLANT LEAKAGE INSPECTION [MZI-3.5]</u></b> .)

## 2007 Mazda CX-9 Grand Touring

2007 ENGINE PERFORMANCE On-Board Diagnostic (MZI-3.5) - CX-9

	<p><b>Scalding engine coolant and steam may shoot out and cause serious injury. It may also damage the engine and cooling system.</b></p> <ul style="list-style-type: none"> <li>• Turn off the engine and wait until it is cool. Even then, be very careful when removing the cap. Wrap a thick cloth around it and slowly turn it counterclockwise to the first stop. Step back while the pressure escapes.</li> <li>• When you're sure all the pressure is gone, press down on the cap using the cloth, turn it, and remove it.</li> <li>• Is the engine coolant fill level correct?</li> </ul>		Go to Step 5.
4	<p><b>INSPECT SENSOR OPERATION</b></p> <ul style="list-style-type: none"> <li>• Run the engine until the engine temperature stabilizes.</li> <li>• Verify that the radiator hoses are hot and the cooling system is pressurized.</li> <li>• Access the PCM and monitor the CHT PID.</li> <li>• Is the temperature more than 77 °C {170.6 °F}?</li> </ul>	Yes	The test is complete. Go to the next step.
		No	Inspect the thermostat operation. Repair if necessary. (see <b><u>THERMOSTAT INSPECTION [MZI-3.5]</u></b> .)
5	<p><b>VERIFY TROUBLESHOOTING OF DTC P0128 HAS BEEN COMPLETED</b></p> <ul style="list-style-type: none"> <li>• Verify that all disconnected connectors are reconnected.</li> <li>• Turn the ignition switch to the ON position (Engine off).</li> <li>• Clear the DTC from the PCM memory using the M-MDS.</li> <li>• Start the engine and run it at idle.</li> <li>• Retrieve DTCs using the M-MDS.</li> <li>• Is the PENDING CODE for this DTC present?</li> </ul>	Yes	Replace PCM, then go to the next step. (see <b><u>PCM REMOVAL/INSTALLATION [MZI-3.5]</u></b> .)
		No	Go to the next step.
6	<p><b>VERIFY AFTER REPAIR</b></p>	Yes	Go to the applicable DTC inspection.

## 2007 Mazda CX-9 Grand Touring

2007 ENGINE PERFORMANCE On-Board Diagnostic (MZI-3.5) - CX-9

<p><b>PROCEDURE</b></p> <ul style="list-style-type: none"> <li>• Perform "AFTER REPAIR PROCEDURE".</li> </ul> <p>(See <b><u>AFTER REPAIR PROCEDURE [MZI-3.5].</u></b>)</p> <ul style="list-style-type: none"> <li>• Are any DTC present?</li> </ul>	<p>(See <b><u>DTC TABLE [MZI-3.5].</u></b>)</p>
<p style="text-align: center;">No</p>	<p>Troubleshooting completed.</p>

### DTC P0132, P0138, P0152, P0158 [MZI-3.5]

#### DTC P0132, P0138, P0152, P0158 (MZI-3.5) DETECTION CONDITION AND POSSIBLE CAUSES

<b>DTC P0132</b>	<b>P0132: Front HO2S (RH) circuit high voltage</b>
<b>DTC P0138</b>	<b>P0138: Rear HO2S (RH) circuit high voltage</b>
<b>DTC P0152</b>	<b>P0152: Front HO2S (LH) circuit high voltage</b>
<b>DTC P0158</b>	<b>P0158: Rear HO2S (LH) circuit high voltage</b>
<b>DETECTION CONDITION</b>	<ul style="list-style-type: none"> <li>• The HO2S signals are monitored for an over voltage condition.</li> <li>• The code is set when the HO2S signal voltage is 1.5 V or more.</li> </ul>
<b>POSSIBLE CAUSE</b>	<ul style="list-style-type: none"> <li>• Short to power supply in the wiring harness or HO2S</li> </ul>

# 2007 Mazda CX-9 Grand Touring

2007 ENGINE PERFORMANCE On-Board Diagnostic (MZI-3.5) - CX-9

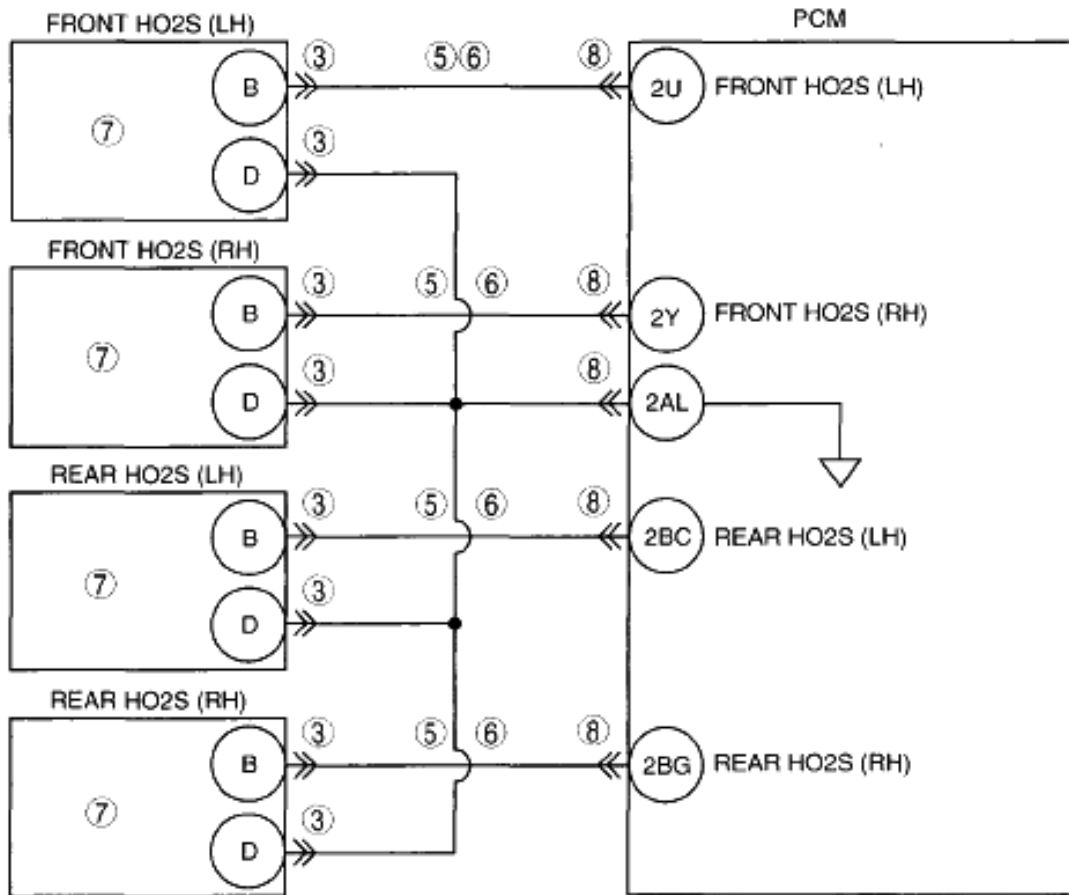

FRONT HO2S (LH, RH)  
WIRING HARNESS-SIDE  
CONNECTOR

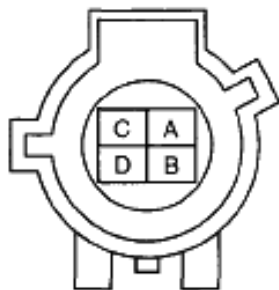

REAR HO2S (LH, RH)  
WIRING HARNESS-SIDE  
CONNECTOR

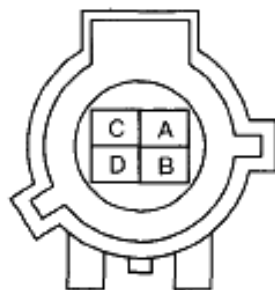

PCM  
WIRING HARNESS-SIDE CONNECTOR

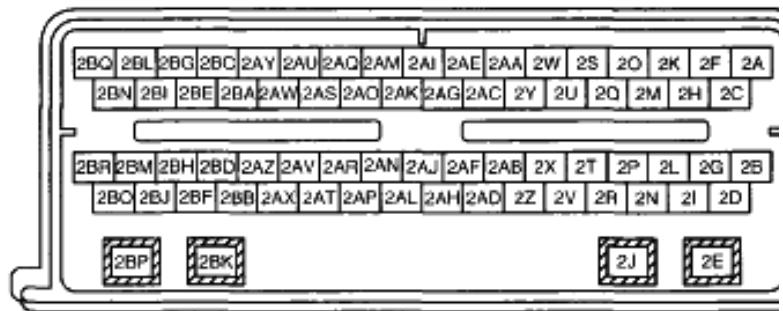

## 2007 Mazda CX-9 Grand Touring

2007 ENGINE PERFORMANCE On-Board Diagnostic (MZI-3.5) - CX-9

### DTC P0132, P0138, P0152, P0158 (MZI-3.5) DIAGNOSTIC PROCEDURE

STEP	INSPECTION		ACTION
1	<b>VERIFY FREEZE FRAME DATA HAS BEEN RECORDED</b> <ul style="list-style-type: none"> <li>• Has FREEZE FRAME DATA been recorded?</li> </ul>	Yes	Go to the next step.
		No	Record FREEZE FRAME DATA on the repair order, then go to the next step.
2	<b>VERIFY RELATED REPAIR INFORMATION AVAILABILITY</b> <ul style="list-style-type: none"> <li>• Verify related Service Bulletins and/or on-line repair information availability.</li> <li>• Is any related Service Bulletins available?</li> </ul>	Yes	Perform repair or diagnosis according to the available Service Bulletins. <ul style="list-style-type: none"> <li>• If the vehicle is not repaired, go to the next step.</li> </ul>
		No	Go to the next step.
3	<b>VISUALLY INSPECT HO2S WIRING HARNESS</b> <p><b>NOTE:</b></p> <ul style="list-style-type: none"> <li>• <b>Disconnect the HO2S wiring harness connector.</b></li> <li>• Turn the ignition switch off.</li> <li>• Disconnect the HO2S connector.</li> <li>• Visually inspect the HO2S wiring harness.                             <ul style="list-style-type: none"> <li>○ Check the connector (both halves) for contamination</li> <li>○ Make sure the connector pins are fully seated</li> </ul> </li> <li>• Is a concern present?</li> </ul>	Yes	Repair if necessary. Go to Step 9.
		No	Go to the next step.
4	<b>INSPECT WHETHER HO2S SIGNAL LEVEL IS TOO HIGH</b> <ul style="list-style-type: none"> <li>• Connect the HO2S connector.</li> <li>• Turn the ignition switch to the ON position (Engine running).</li> <li>• Access the PCM and monitor the HO2S signal PID.</li> <li>• Is the voltage less than 1.1 V?</li> </ul>	Yes	Go to Step 6.
		No	Go to the next step.
5	<b>PERFORM THOROUGH WIGGLE TEST ON HO2S WIRING HARNESS</b>	Yes	Repair if necessary. Go to Step 9.

## 2007 Mazda CX-9 Grand Touring

2007 ENGINE PERFORMANCE On-Board Diagnostic (MZI-3.5) - CX-9

	<ul style="list-style-type: none"> <li>• Turn the ignition switch off.</li> <li>• Turn the ignition switch to the ON position (Engine off).</li> <li>• Access the PCM and monitor the HO2S signal PID.</li> <li>• Perform a thorough wiggle test on the HO2S wiring harness.</li> <li>• Does the voltage change during the wiggle test?</li> </ul>	No	Perform the "INTERMITTENT CONCERN TROUBLESHOOTING". Then go to the next step.
6	<b>INSPECT HO2S CIRCUIT FOR SHORT TO POWER SUPPLY IN WIRING HARNESS</b> <ul style="list-style-type: none"> <li>• Turn the ignition switch off.</li> <li>• Disconnect the PCM connector.</li> <li>• Turn the ignition switch to the ON position (Engine off).</li> <li>• Measure the voltage between HO2S terminal B and body ground.</li> <li>• Is any voltage present?</li> </ul>	Yes	Repair or replace suspected part, Then go to the next step.
		No	Go to Step 9.
7	<b>INSPECT HO2S</b> <ul style="list-style-type: none"> <li>• For DTC P0132 Inspect the front HO2S(RH)</li> <li>• For DTC P0138 Inspect the rear HO2S(RH)</li> <li>• For DTC P0152 Inspect the front HO2S(LH)</li> <li>• For DTC P0138 Inspect the rear HO2S(LH)</li> </ul> <p>(see <b><u>FRONT HEATED OXYGEN SENSOR (HO2S) INSPECTION [MZI-3.5].</u></b> )</p> <p>(see <b><u>REAR HEATED OXYGEN SENSOR (HO2S) INSPECTION [MZI-3.5].</u></b> )</p> <ul style="list-style-type: none"> <li>• Is there any malfunction?</li> </ul>	Yes	Replace the HO2S. (see <b><u>FRONT HEATED OXYGEN SENSOR (HO2S) REMOVAL/INSTALLATION [MZI-3.5].</u></b> ) (see <b><u>REAR HEATED OXYGEN SENSOR (HO2S) REMOVAL/INSTALLATION [MZI-3.5].</u></b> ) Then go to the next step.
		No	Go to the next step.
8	<b>INSPECT FOR CORRECT PCM OPERATION</b>	Yes	Go to the next step.



## 2007 Mazda CX-9 Grand Touring

2007 ENGINE PERFORMANCE On-Board Diagnostic (MZI-3.5) - CX-9

	<ul style="list-style-type: none"> <li>• Disconnect all the PCM connectors.</li> <li>• Visually inspect for:             <ul style="list-style-type: none"> <li>○ Pushed out pins</li> <li>○ Corrosion</li> </ul> </li> <li>• Connect all the PCM connectors and verify that they seat correctly.</li> </ul>	No	Repair if necessary. Then go to the next step.
9	<b>VERIFY TROUBLESHOOTING OF MISFIRE DTC HAS BEEN COMPLETED</b> <ul style="list-style-type: none"> <li>• Verify that all disconnected connectors are reconnected.</li> <li>• Turn the ignition switch to the ON position (Engine off).</li> <li>• Clear the DTC from the PCM memory using the M-MDS.</li> <li>• Start the engine and run it at idle.</li> <li>• Retrieve DTCs using the M-MDS.</li> <li>• Is the PENDING CODE for this DTC present?</li> </ul>	Yes	Replace PCM, then go to the next step. (see <b><u>PCM REMOVAL/INSTALLATION [MZI-3.5]</u></b> .)
		No	Go to the next step.
10	<b>VERIFY AFTER REPAIR PROCEDURE</b> <ul style="list-style-type: none"> <li>• Perform "AFTER REPAIR PROCEDURE".</li> </ul> <p>(See <b><u>AFTER REPAIR PROCEDURE [MZI-3.5]</u></b>.)</p> <ul style="list-style-type: none"> <li>• Are any DTC present?</li> </ul>	Yes	Go to the applicable DTC inspection. (See <b><u>DTC TABLE [MZI-3.5]</u></b> .)
		No	Troubleshooting completed.

### DTC P0133, P0139, P0153, P0159 [MZI-3.5]

#### DTC P0133, P0139, P0153, P0159 (MZI-3.5) DETECTION CONDITION AND POSSIBLE CAUSES

<b>DTC P0133</b>	<b>P0133: Front HO2S (RH) circuit slow response</b>
<b>DTC P0139</b>	<b>P0139: Rear HO2S (RH) circuit slow response</b>
<b>DTC P0153</b>	<b>P0153: Front HO2S (LH) circuit slow response</b>
<b>DTC P0159</b>	<b>P0159: Rear HO2S (LH) circuit slow response</b>
<b>DETECTION CONDITION</b>	<ul style="list-style-type: none"> <li>• The HO2S monitor checks the HO2S frequency and amplitude.</li> <li>• The test fails if the frequency and amplitude fall below a calibrated limit during testing.</li> </ul>

## 2007 Mazda CX-9 Grand Touring

2007 ENGINE PERFORMANCE On-Board Diagnostic (MZI-3.5) - CX-9

### POSSIBLE CAUSE

- Contaminated HO2S
- Exhaust leaks
- Open circuit in wiring harness between PCM terminal 2Y (wiring harness-side) and front HO2S (RH) terminal B (wiring harness-side)
- Open circuit in wiring harness between PCM terminal 2BG (wiring harness-side) and rear HO2S (RH) terminal B (wiring harness-side)
- Open circuit in wiring harness between PCM terminal 2U (wiring harness-side) and front HO2S (LH) terminal B (wiring harness-side)
- Open circuit in wiring harness between PCM terminal 2BC (wiring harness-side) and rear HO2S (LH) terminal B (wiring harness-side)
- Open circuit in wiring harness between PCM terminal 2AL (wiring harness-side) and HO2S terminal D (wiring harness-side)
- Short to ground in wiring harness between PCM terminal 1BJ (wiring harness-side) and PCM terminal 2Y (wiring harness-side)
- Short to ground in wiring harness between PCM terminal 1BJ (wiring harness-side) and PCM terminal 2BG (wiring harness-side)
- Short to ground in wiring harness between PCM terminal 1BJ (wiring harness-side) and PCM terminal 2U (wiring harness-side)
- Short to ground in wiring harness between PCM terminal 1BJ (wiring harness-side) and PCM terminal 2BC (wiring harness-side)
- Short to ground in wiring harness between HO2S terminal A (wiring harness-side) and battery negative terminal
- Short to ground in wiring harness between HO2S terminal A (wiring harness-side) and HO2S terminal C (wiring harness-side)
- Short to ground in wiring harness between HO2S terminal A (wiring harness-side) and HO2S terminal D (wiring harness-side)
- Short to ground in wiring harness between HO2S terminal A (wiring harness-side) and HO2S terminal B (wiring harness-side)
- Short to ground in wiring harness between PCM terminal 2J and front HO2S (RH) terminal A
- Short to ground in wiring harness between PCM terminal 2AS and front HO2S (LH) terminal A
- Short to ground in wiring harness between PCM terminal 2E and rear HO2S (RH) terminal A
- Short to ground in wiring harness between PCM terminal 2AO and rear HO2S (LH) terminal A
- Incorrect fueling
- MAF sensor malfunction
- Deteriorating HO2S
- Inlet air leaks

# 2007 Mazda CX-9 Grand Touring

2007 ENGINE PERFORMANCE On-Board Diagnostic (MZI-3.5) - CX-9

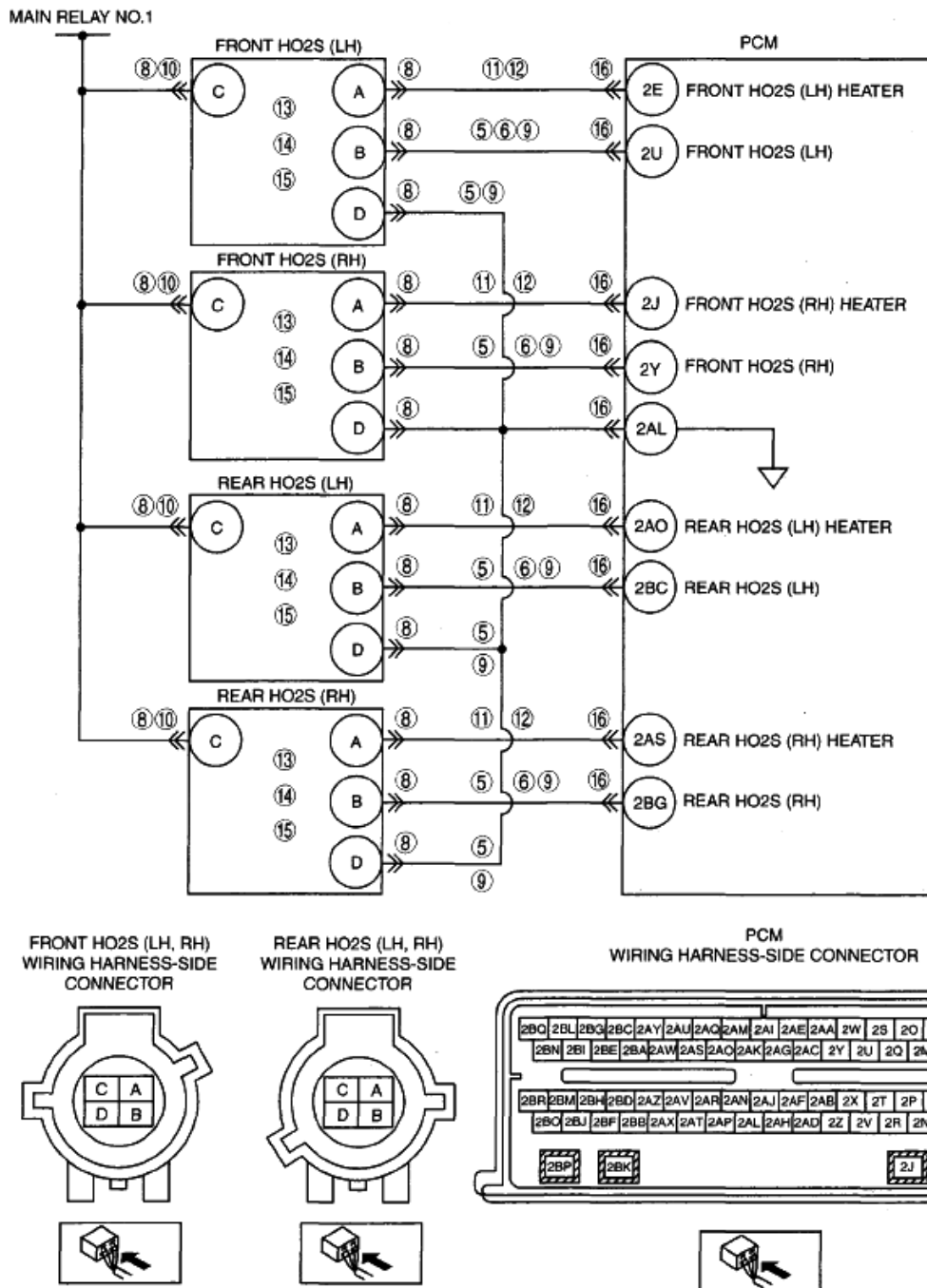

**Fig. 11: HO2S Circuit Diagram**  
Courtesy of MAZDA MOTORS CORP.

## DIAGNOSTIC PROCEDURE

### DTC P0133, P0139, P0153, P0159 (MZI-3.5) DIAGNOSTIC PROCEDURE

STEP	INSPECTION		ACTION
1	VERIFY FREEZE FRAME DATA	Yes	Go to the next step.

## 2007 Mazda CX-9 Grand Touring

2007 ENGINE PERFORMANCE On-Board Diagnostic (MZI-3.5) - CX-9

	<p><b>HAS BEEN RECORDED</b></p> <ul style="list-style-type: none"> <li>Has FREEZE FRAME DATA been recorded?</li> </ul>	No	Record FREEZE FRAME DATA on the repair order, then go to the next step.
2	<p><b>VERIFY RELATED REPAIR INFORMATION AVAILABILITY</b></p> <ul style="list-style-type: none"> <li>Verify related Service Bulletins and/or on-line repair information availability.</li> <li>Is any related Service Bulletins available?</li> </ul>	Yes	<p>Perform repair or diagnosis according to the available Service Bulletins.</p> <ul style="list-style-type: none"> <li>If the vehicle is not repaired, go to the next step.</li> </ul>
		No	Go to the next step.
3	<p><b>PERFORM KOER SELF-TEST</b></p> <ul style="list-style-type: none"> <li>Verify that the engine is at normal operating temperature.</li> <li>Perform the KOER self-test.</li> <li>Are DTCs P0040, P0041 or P1127 present?</li> </ul>	Yes	Go to the appropriate DTC troubleshooting. (See <b><u>DTC TABLE [MZI-3.5]</u></b> .)
		No	Go to the next step.
4	<p><b>INSPECT FOR UNMETERED AIR LEAKS</b></p> <p><b>NOTE:</b></p> <ul style="list-style-type: none"> <li><b>Fuel calculations can be affected by unmetered air leaks.</b></li> <li>Carefully inspect the following areas for potential air leaks: <ul style="list-style-type: none"> <li>Hoses connecting to the MAF sensor assembly</li> <li>Hoses connecting to the throttle body</li> <li>Intake manifold gasket leaks</li> <li>PCV system</li> <li>The vacuum lines are disconnected</li> <li>Improperly seated engine oil dipstick, tube or oil filler cap</li> <li>Exhaust leaks at flanges and gaskets</li> </ul> </li> <li>Are any air leaks present?</li> </ul>	Yes	Repair the source of the air leak. Then go to Step 17.
		No	Go to the next step.
5	<p><b>INSPECT HO2S CIRCUIT (S) FOR</b></p>	Yes	Go to the next step.

## 2007 Mazda CX-9 Grand Touring

2007 ENGINE PERFORMANCE On-Board Diagnostic (MZI-3.5) - CX-9

	No	Repair or replace suspected part, Then go to Step 17.
<p><b>OPEN CIRCUIT IN WIRING HARNESS</b></p> <ul style="list-style-type: none"><li>• Turn the ignition switch off.</li><li>• Remove the jumper wire (s).</li><li>• Visually inspect the HO2S wiring harness for exposed wiring, water contamination, corrosion, and proper assembly.</li><li>• Disconnect the PCM connector.</li><li>• Measure the resistance between the following terminals:<ul style="list-style-type: none"><li>○ PCM terminal 2Y (wiring harness-side) and front HO2S (RH) terminal B (wiring harness-side)</li><li>○ PCM terminal 2BG (wiring harness-side) and rear HO2S (RH) terminal B (wiring harness-side)</li><li>○ PCM terminal 2U (wiring harness-side) and front HO2S (LH) terminal B (wiring harness-side)</li><li>○ PCM terminal 2BC (wiring harness-side) and rear HO2S (LH) terminal B (wiring harness-side)</li><li>○ PCM terminal 2AL (wiring harness-side) and HO2S terminal D (wiring harness-side)</li></ul></li><li>• Are the resistances less than 5 ohms?</li></ul>	6	<p><b>INSPECT HO2S CIRCUIT FOR SHORT TO POWER SUPPLY</b></p> <ul style="list-style-type: none"><li>• Measure the resistance between the following terminals:<ul style="list-style-type: none"><li>○ PCM terminal 1BJ (wiring harness-side) and PCM terminal 2Y (wiring harness-side)</li><li>○ PCM terminal 1BJ (wiring</li></ul></li></ul>

## 2007 Mazda CX-9 Grand Touring

2007 ENGINE PERFORMANCE On-Board Diagnostic (MZI-3.5) - CX-9

	<p>harness-side) and PCM terminal 2BG (wiring harness-side)</p> <ul style="list-style-type: none"> <li>○ PCM terminal 1BJ (wiring harness-side) and PCM terminal 2U (wiring harness-side)</li> <li>○ PCM terminal 1BJ (wiring harness-side) and PCM terminal 2BC (wiring harness-side)</li> </ul> <ul style="list-style-type: none"> <li>● Is the resistance more than 10 kilohms?</li> </ul>	No	Go to Step 10.
7	<p><b>INSPECT FOR SOURCE OF POTENTIAL HO2S CONTAMINATION</b></p> <ul style="list-style-type: none"> <li>● Investigate the following items as potential sources of HO2S contamination: <ul style="list-style-type: none"> <li>○ Use of unapproved silicon sealers</li> <li>○ Fuel contaminated by silicon additives</li> <li>○ Excessive oil consumption</li> <li>○ Glycol leaking internally in the engine</li> <li>○ Lead-contaminated fuel</li> <li>○ Short drive cycles in cold weather</li> <li>○ Use of unapproved cleaning agents</li> </ul> </li> <li>● Is a concern present?</li> </ul>	Yes	Repair the source of the contamination. Change the engine oil and oil filter. Then go to Step 17.
		No	Go to the next step.
8	<p><b>VISUALLY INSPECT HO2S WIRING HARNESS</b></p> <ul style="list-style-type: none"> <li>● Connect the PCM connector.</li> <li>● Visually inspect the HO2S wiring harness for exposed wiring water contamination, corrosion, and proper assembly.</li> <li>● Is a concern present?</li> </ul>	Yes	Repair if necessary. Then go to the next step.
		No	Go to the next step.
9	<p><b>INSPECT HO2S AND SIGRTN</b></p>	Yes	Go to the next step.

## 2007 Mazda CX-9 Grand Touring

2007 ENGINE PERFORMANCE On-Board Diagnostic (MZI-3.5) - CX-9

<p><b>CIRCUITS FOR OPEN CIRCUIT IN WIRING HARNESS</b></p> <p><b>NOTE:</b></p> <ul style="list-style-type: none"> <li>• <b>Verify the wiring harness terminals are in the proper location.</b></li> <li>• Measure the resistance between the following terminals:             <ul style="list-style-type: none"> <li>○ PCM terminal 2Y (wiring harness-side) and front HO2S (RH) terminal B (wiring harness-side)</li> <li>○ PCM terminal 2BG (wiring harness-side) and rear HO2S (RH) terminal B (wiring harness-side)</li> <li>○ PCM terminal 2U (wiring harness-side) and front HO2S (LH) terminal B (wiring harness-side)</li> <li>○ PCM terminal 2BC (wiring harness-side) and rear HO2S (LH) terminal B (wiring harness-side)</li> <li>○ PCM terminal 2AL (wiring harness-side) and HO2S terminal D (wiring harness-side)</li> </ul> </li> <li>• Are the resistances less than 5 ohms?</li> </ul>	No	Repair or replace suspected part, Then go to Step 17.	
10	<p><b>INSPECT HO2S CONTROL CIRCUIT IN WIRING HARNESS</b></p> <ul style="list-style-type: none"> <li>• Turn the ignition switch off.</li> <li>• Disconnect the HO2S connector.</li> <li>• Perform the KOEO self-test.</li> <li>• Measure the voltage between: HO2S connector terminal C and D on the wiring harness side.</li> <li>• Is the voltage more than 10 V?</li> </ul>	Yes	Go to the next step.
		No	Repair or replace suspected part, Then go to the next step.
11	<p><b>INSPECT HO2S HEATER FOR SHORT IN WIRING HARNESS</b></p>	Yes	Go to the next step.

## 2007 Mazda CX-9 Grand Touring

2007 ENGINE PERFORMANCE On-Board Diagnostic (MZI-3.5) - CX-9

	<ul style="list-style-type: none"> <li>• Turn the ignition switch off.</li> <li>• Disconnect the HO2S connector.</li> <li>• Disconnect the PCM connector.</li> <li>• Measure the resistance between the following terminals:             <ul style="list-style-type: none"> <li>○ HO2S terminal A (wiring harness-side) and battery negative terminal</li> <li>○ HO2S terminal A (wiring harness-side) and HO2S terminal C (wiring harness-side)</li> <li>○ HO2S terminal A (wiring harness-side) and HO2S terminal D (wiring harness-side)</li> <li>○ HO2S terminal A (wiring harness-side) and HO2S terminal B (wiring harness-side)</li> </ul> </li> <li>• Are the resistances more than 10 kilohms?</li> </ul>	No	Repair or replace suspected part, Then go to Step 17.
12	<p><b>INSPECT HO2S HEATER CIRCUIT FOR OPEN CIRCUIT IN WIRING HARNESS</b></p> <ul style="list-style-type: none"> <li>• Measure the resistance:             <ul style="list-style-type: none"> <li>○ For DTC P0133 measure resistance between PCM terminal 2J and front HO2S (RH) terminal A</li> <li>○ For DTC P0153 measure resistance between PCM terminal 2AS and rear HO2S (RH) terminal A</li> <li>○ For DTC P0139 measure resistance between PCM terminal 2E and front HO2S (LH) terminal A</li> <li>○ For DTC P0159 measure resistance between PCM terminal 2AO and rear HO2S (LH) terminal A</li> </ul> </li> </ul>	Yes	Go to the next step.
		No	Repair or replace suspected part, Then go to the next step.



## 2007 Mazda CX-9 Grand Touring

2007 ENGINE PERFORMANCE On-Board Diagnostic (MZI-3.5) - CX-9

	<ul style="list-style-type: none"> <li>Is the resistance less than 5 ohms?</li> </ul>		
13	<b>INSPECT INTERNAL RESISTANCE OF HO2S HEATER</b> <ul style="list-style-type: none"> <li>Measure the resistance between the suspect HO2S terminal A and C at component side.</li> <li>Is the resistance between 3-30 ohms?</li> </ul>	Yes	Go to the next step.
		No	Install a new HO2S. Then go to Step 17.
14	<b>INSPECT HO2S HEATER CIRCUIT FOR INTERNAL SHORT TO SIGRTN OR GROUND</b> <ul style="list-style-type: none"> <li>Measure the resistance between:                             <ul style="list-style-type: none"> <li>HO2S terminal A and D at component side</li> <li>HO2S terminal A at component side and battery negative terminal</li> </ul> </li> <li>Is the resistance more than 10 kilohms?</li> </ul>	Yes	Go to the next step.
		No	Replace the HO2S. (see <b><u>FRONT HEATED OXYGEN SENSOR (HO2S) REMOVAL/INSTALLATION [MZI-3.5].</u></b> ) (see <b><u>REAR HEATED OXYGEN SENSOR (HO2S) REMOVAL/INSTALLATION [MZI-3.5].</u></b> ) Then go to Step 17.
15	<b>INSPECT HO2S</b> <ul style="list-style-type: none"> <li>For DTC P0133 Inspect the front HO2S(RH)</li> <li>For DTC P0139 Inspect the rear HO2S(RH)</li> <li>For DTC P0153 Inspect the front HO2S(LH)</li> <li>For DTC P0159 Inspect the rear HO2S(LH)</li> </ul> <p>(see <b><u>FRONT HEATED OXYGEN SENSOR (HO2S) INSPECTION [MZI-3.5].</u></b>)</p> <p>(see <b><u>REAR HEATED OXYGEN SENSOR (HO2S) INSPECTION [MZI-3.5].</u></b>)</p> <ul style="list-style-type: none"> <li>Is there any malfunction?</li> </ul>	Yes	Replace the HO2S. (see <b><u>FRONT HEATED OXYGEN SENSOR (HO2S) REMOVAL/INSTALLATION [MZI-3.5].</u></b> ) (see <b><u>REAR HEATED OXYGEN SENSOR (HO2S) REMOVAL/INSTALLATION [MZI-3.5].</u></b> ) Then go to Step 17.
		No	Go to the next step.
16	<b>INSPECT FOR CORRECT PCM OPERATION</b>	Yes	Go to the next step.

## 2007 Mazda CX-9 Grand Touring

2007 ENGINE PERFORMANCE On-Board Diagnostic (MZI-3.5) - CX-9

	<ul style="list-style-type: none"> <li>• Disconnect all the PCM connectors.</li> <li>• Visually inspect for: <ul style="list-style-type: none"> <li>○ Pushed out pins</li> <li>○ Corrosion</li> </ul> </li> <li>• Connect all the PCM connectors and verify that they seat correctly.</li> <li>• Retrieve DTCs using the M-MDS.</li> <li>• Is the PENDING CODE for this DTC present?</li> </ul>	No	The system is correctly. Go to the next step.
17	<p><b>VERIFY TROUBLESHOOTING OF MISFIRE DTC HAS BEEN COMPLETED</b></p> <ul style="list-style-type: none"> <li>• Verify that all disconnected connectors are reconnected.</li> <li>• Turn the ignition switch to the ON position (Engine off).</li> <li>• Clear the DTC from the PCM memory using the M-MDS.</li> <li>• Retrieve DTCs using the M-MDS.</li> <li>• Is the PENDING CODE for this DTC present?</li> </ul>	Yes	Replace PCM, then go to the next step. (see <b><u>PCM REMOVAL/INSTALLATION [MZI-3.5]</u></b> .)
		No	Go to the next step.
18	<p><b>VERIFY AFTER REPAIR PROCEDURE</b></p> <ul style="list-style-type: none"> <li>• Perform "AFTER REPAIR PROCEDURE".</li> </ul> <p>(See <b><u>AFTER REPAIR PROCEDURE [MZI-3.5]</u></b>.)</p> <ul style="list-style-type: none"> <li>• Are any DTC present?</li> </ul>	Yes	Go to the applicable DTC inspection. (See <b><u>DTC TABLE [MZI-3.5]</u></b> .)
		No	Troubleshooting completed.

### DTC P0135, P0141, P0155, P0161 [MZI-3.5]

#### DTC P0135, P0141, P0155, P0161 (MZI-3.5) DETECTION CONDITION AND POSSIBLE CAUSES

<b>DTC P0135</b>	<b>P0135: Front HO2S heater (RH) circuit</b>
<b>DTC P0141</b>	<b>P0141: Rear HO2S heater (RH) circuit</b>
<b>DTC P0155</b>	<b>P0155: Front HO2S heater (LH) circuit</b>
<b>DTC P0161</b>	<b>P0161: Rear HO2S heater (LH) circuit</b>
	<ul style="list-style-type: none"> <li>• During testing the heated oxygen sensor heaters are checked for open and short ci</li> </ul>

## 2007 Mazda CX-9 Grand Touring

2007 ENGINE PERFORMANCE On-Board Diagnostic (MZI-3.5) - CX-9

<b>DETECTION CONDITION</b>	and excessive current draw. <ul style="list-style-type: none"><li>• The test fails when the current draw exceeds a calibrated limit or an open or short circuit is detected.</li></ul>
<b>POSSIBLE CAUSE</b>	<ul style="list-style-type: none"><li>• Short to ground between HO2S terminal A and HO2S terminal C</li><li>• Short to ground between HO2S terminal A and HO2S terminal D</li><li>• Short to ground between HO2S terminal A and HO2S terminal B</li><li>• Water in the wiring harness connector</li><li>• Open circuit between PCM terminal 2J and front HO2S (RH) terminal A</li><li>• Open circuit between PCM terminal 2AS and rear HO2S (RH) terminal A</li><li>• Open circuit between PCM terminal 2E and front HO2S (LH) terminal A</li><li>• Open circuit between PCM terminal 2AO and rear HO2S (LH) terminal A</li><li>• Low battery voltage</li><li>• Corrosion or incorrect harness connections</li><li>• HO2S heater malfunction</li></ul>

# 2007 Mazda CX-9 Grand Touring

2007 ENGINE PERFORMANCE On-Board Diagnostic (MZI-3.5) - CX-9

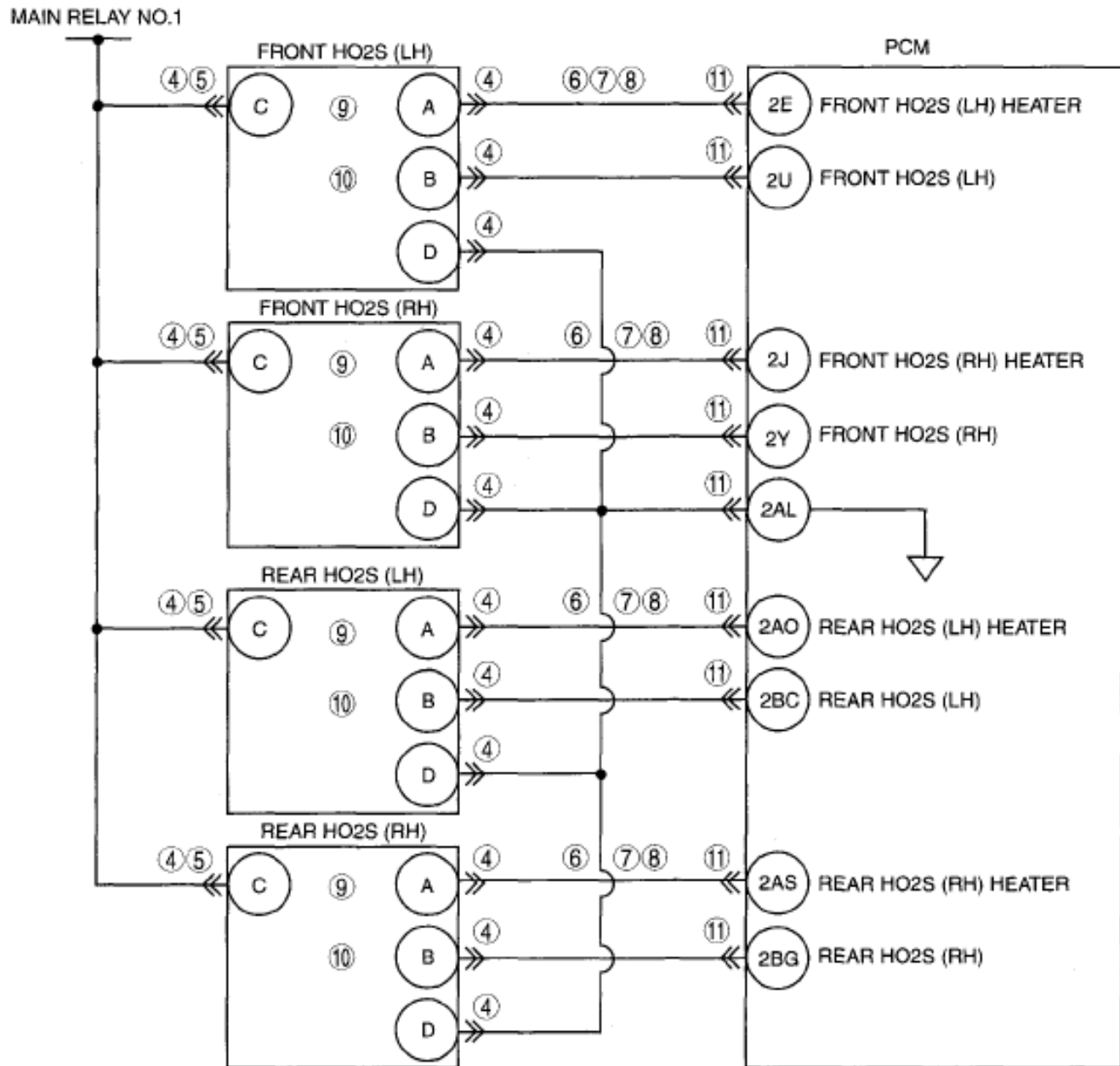

FRONT HO2S (LH, RH)  
WIRING HARNESS-SIDE  
CONNECTOR

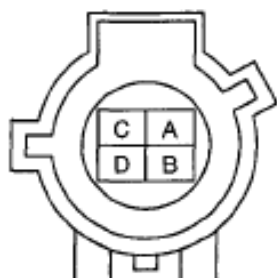

REAR HO2S (LH, RH)  
WIRING HARNESS-SIDE  
CONNECTOR

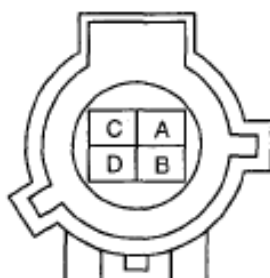

PCM  
WIRING HARNESS-SIDE CONNECTOR

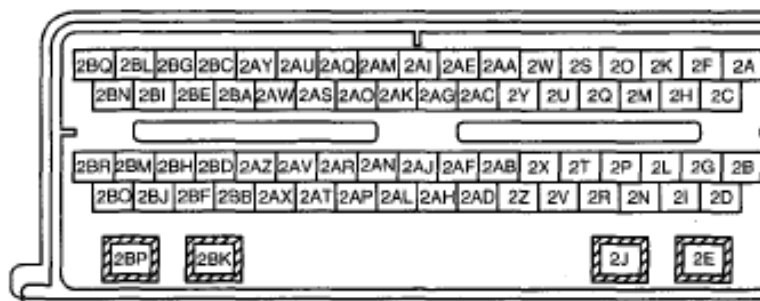

## 2007 Mazda CX-9 Grand Touring

2007 ENGINE PERFORMANCE On-Board Diagnostic (MZI-3.5) - CX-9

### DIAGNOSTIC PROCEDURE

#### DTC P0135, P0141, P0155, P0161 (MZI-3.5) DIAGNOSTIC PROCEDURE

STEP	INSPECTION	ACTION	
1	<b>VERIFY FREEZE FRAME DATA HAS BEEN RECORDED</b> <ul style="list-style-type: none"> <li>• Has FREEZE FRAME DATA been recorded?</li> </ul>	Yes	Go to the next step.
		No	Record FREEZE FRAME DATA on the repair order, then go to the next step.
2	<b>VERIFY RELATED REPAIR INFORMATION AVAILABILITY</b> <ul style="list-style-type: none"> <li>• Verify related Service Bulletins and/or on-line repair information availability.</li> <li>• Is any related Service Bulletins available?</li> </ul>	Yes	Perform repair or diagnosis according to the available Service Bulletins. <ul style="list-style-type: none"> <li>• If the vehicle is not repaired, go to the next step.</li> </ul>
		No	Go to the next step.
3	<b>INSPECT FOR SOURCE OF POTENTIAL HO2S CONTAMINATION</b> <ul style="list-style-type: none"> <li>• Investigate the following items as potential sources of HO2S contamination:                             <ul style="list-style-type: none"> <li>○ Use of unapproved silicon sealers</li> <li>○ Fuel contaminated by silicon additives</li> <li>○ Excessive oil consumption</li> <li>○ Glycol leaking internally in the engine</li> <li>○ Lead-contaminated fuel</li> <li>○ Short drive cycles in cold weather</li> <li>○ Use of unapproved cleaning agents</li> </ul> </li> <li>• Is a concern present?</li> </ul>	Yes	Repair the source of the contamination. Change the engine oil and oil filter. Then go to the next step.
		No	Go to the next step.
4	<b>VISUALLY INSPECT HO2S WIRING HARNESS</b> <ul style="list-style-type: none"> <li>• Connect the PCM connector.</li> <li>• Visually inspect the HO2S wiring harness for exposed wiring water contamination, corrosion, and</li> </ul>	Yes	Repair or replace suspected part, Then go to Step 12.
		No	Go to the next step.

## 2007 Mazda CX-9 Grand Touring

2007 ENGINE PERFORMANCE On-Board Diagnostic (MZI-3.5) - CX-9

	<p>proper assembly.</p> <ul style="list-style-type: none"> <li>• Is a concern present?</li> </ul>		
5	<p><b>INSPECT POWER SUPPLY IN WIRING HARNESS</b></p> <ul style="list-style-type: none"> <li>• Disconnect suspect HO2S connector.</li> <li>• Turn the ignition switch to the ON position (Engine off).</li> <li>• Measure the voltage between suspect HO2S connector terminal A and C, on the wiring harness side.</li> <li>• Is the voltage more than 10 V?</li> </ul>	Yes	Turn the ignition switch off. Go to the next step.
		No	Repair or replace suspected part, Go to Step 12.
6	<p><b>INSPECT HO2S HEATER FOR SHORT TO GROUND</b></p> <ul style="list-style-type: none"> <li>• Disconnect the PCM connector.</li> <li>• Measure the resistance between HO2S terminal A on the wiring harness side and body ground.</li> <li>• Is the resistance more than 10 kilohms?</li> </ul>	Yes	Go to the next step.
		No	Repair or replace suspected part, Go to Step 12.
7	<p><b>INSPECT HO2S HEATER FOR SHORT IN WIRING HARNESS</b></p> <ul style="list-style-type: none"> <li>• Measure the resistance between the following terminals: <ul style="list-style-type: none"> <li>○ HO2S terminal A (wiring harness-side) and HO2S terminal C (wiring harness-side)</li> <li>○ HO2S terminal A (wiring harness-side) and HO2S terminal D (wiring harness-side)</li> <li>○ HO2S terminal A (wiring harness-side) and HO2S terminal B (wiring harness-side)</li> </ul> </li> <li>• Are the resistances more than 10 kilohms?</li> </ul>	Yes	Go to the next step.
		No	Repair or replace suspected part, Go to Step 12.
8	<p><b>INSPECT HO2S HEATER CIRCUIT FOR OPEN CIRCUIT IN WIRING</b></p>	Yes	Go to the next step.

## 2007 Mazda CX-9 Grand Touring

2007 ENGINE PERFORMANCE On-Board Diagnostic (MZI-3.5) - CX-9

	<p><b>HARNES</b></p> <ul style="list-style-type: none"> <li>• For DTC P0135, measure the resistance between PCM terminal 2J and front HO2S (RH) terminal A.</li> <li>• For DTC P0141, measure the resistance between PCM terminal 2AS and rear HO2S (RH) terminal A.</li> <li>• For DTC P0155, measure the resistance between PCM terminal 2E and front HO2S (LH) terminal A.</li> <li>• For DTC P0161, measure the resistance between PCM terminal 2AO and rear HO2S (LH) terminal A.</li> <li>• Is the resistance less than 5.0 ohms?</li> </ul>	No	Repair or replace suspected part, Go to Step 12.
9	<p><b>INSPECT INTERNAL RESISTANCE OF HO2S HEATER</b></p> <ul style="list-style-type: none"> <li>• Measure the resistance between the suspect HO2S terminal A and C, on the component side.</li> <li>• Is the resistance between 3-30 ohms?</li> </ul>	Yes	Go to the next step.
		No	Replace HO2S. (see <b><u>FRONT HEATED OXYGEN SENSOR (HO2S) REMOVAL/INSTALLATION [MZI-3.5].</u></b> ) (see <b><u>REAR HEATED OXYGEN SENSOR (HO2S) REMOVAL/INSTALLATION [MZI-3.5].</u></b> ) Go to Step 12.
10	<p><b>INSPECT HO2S CASE FOR SHORT TO POWER SUPPLY, HTR, AND SIGNRTN</b></p> <ul style="list-style-type: none"> <li>• Measure the resistance between the suspect HO2S terminal A and D at component side.</li> <li>• Measure the resistance between the suspect HO2S terminal A and body ground.</li> <li>• Is the resistance more than 10 kilohms?</li> </ul>	Yes	Go to the next step.
		No	Replace HO2S. (see <b><u>FRONT HEATED OXYGEN SENSOR (HO2S) REMOVAL/INSTALLATION [MZI-3.5].</u></b> ) (see <b><u>REAR HEATED OXYGEN SENSOR (HO2S) INSPECTION [MZI-3.5].</u></b> ) Go to the next step.
11	<p><b>INSPECT FOR CORRECT PCM OPERATION</b></p>	Yes	Go to the next step.

## 2007 Mazda CX-9 Grand Touring

2007 ENGINE PERFORMANCE On-Board Diagnostic (MZI-3.5) - CX-9

	<ul style="list-style-type: none"> <li>• Disconnect all the PCM connectors.</li> <li>• Visually inspect for: <ul style="list-style-type: none"> <li>○ Pushed out pins</li> <li>○ Corrosion</li> </ul> </li> <li>• Connect all the PCM connectors and verify that they seat correctly.</li> <li>• Retrieve DTCs using the M-MDS.</li> <li>• Is the PENDING CODE for this DTC present?</li> </ul>	No	The system is correctly. Go to the next step.
12	<p><b>VERIFY TROUBLESHOOTING OF MISFIRE DTC HAS BEEN COMPLETED</b></p> <ul style="list-style-type: none"> <li>• Verify that all disconnected connectors are reconnected.</li> <li>• Turn the ignition switch to the ON position (Engine off).</li> <li>• Clear the DTC from the PCM memory using the M-MDS.</li> <li>• Retrieve DTCs using the M-MDS.</li> <li>• Is the PENDING CODE for this DTC present?</li> </ul>	Yes	Replace PCM, then go to the next step. (see <b><u>PCM REMOVAL/INSTALLATION [MZI-3.5]</u></b> .)
		No	Go to the next step.
13	<p><b>VERIFY AFTER REPAIR PROCEDURE</b></p> <ul style="list-style-type: none"> <li>• Perform "AFTER REPAIR PROCEDURE".</li> </ul> <p>(See <b><u>AFTER REPAIR PROCEDURE [MZI-3.5]</u></b>.)</p> <ul style="list-style-type: none"> <li>• Are any DTC present?</li> </ul>	Yes	Go to the applicable DTC inspection. (See <b><u>DTC TABLE [MZI-3.5]</u></b> .)
		No	Troubleshooting completed.

### DTC P0148 [MZI-3.5]

#### DTC P0148 (MZI-3.5) DETECTION CONDITION AND POSSIBLE CAUSES

<b>DTC P0148</b>	<b>Fuel delivery error</b>
<b>DETECTION CONDITION</b>	<ul style="list-style-type: none"> <li>• At least 1 bank is lean at wide open throttle (WOT).</li> </ul>
<b>POSSIBLE CAUSE</b>	<ul style="list-style-type: none"> <li>• Severely restricted fuel filter</li> <li>• Severely restricted fuel supply line</li> </ul>



## 2007 Mazda CX-9 Grand Touring

2007 ENGINE PERFORMANCE On-Board Diagnostic (MZI-3.5) - CX-9

- Damaged or worn fuel pump
- Damaged or contaminated MAF sensor

### DIAGNOSTIC PROCEDURE

#### DTC P0148 (MZI-3.5) DIAGNOSTIC PROCEDURE

STEP	INSPECTION	ACTION	
1	<b>VERIFY FREEZE FRAME DATA HAS BEEN RECORDED</b> <ul style="list-style-type: none"> <li>• Has FREEZE FRAME DATA been recorded?</li> </ul>	Yes	Go to the next step.
		No	Record FREEZE FRAME DATA on the repair order, then go to the next step.
2	<b>VERIFY RELATED REPAIR INFORMATION AVAILABILITY</b> <ul style="list-style-type: none"> <li>• Verify related Service Bulletins and/or on-line repair information availability.</li> <li>• Is any related Service Bulletins available?</li> </ul>	Yes	Perform repair or diagnosis according to the available Service Bulletins. <ul style="list-style-type: none"> <li>• If the vehicle is not repaired, go to the next step.</li> </ul>
		No	Go to the next step.
3	<b>INSPECT SYSTEM INTEGRITY</b> <ul style="list-style-type: none"> <li>• Visually inspect the complete fuel delivery system for damage and leakage.</li> <li>• Check the following:                             <ul style="list-style-type: none"> <li>○ Fuel lines and connections</li> <li>○ Relays</li> <li>○ Fuel tank</li> <li>○ Fuel pump</li> <li>○ Fuel pressure regulator</li> <li>○ Fuel pulse damper</li> <li>○ Fuel rail at fuel injectors</li> <li>○ Damaged connector pins</li> <li>○ Electrical connectors not fully engaged</li> </ul> </li> <li>• Verify that the vehicle has followed the maintenance schedule. A new fuel filter should have been installed within the last 48,280 km {29,934 mph}.</li> <li>• Verify that the fuse integrity.</li> </ul>	Yes	Repair if necessary. Then go to Step 11.
		No	Go to the next step.

## 2007 Mazda CX-9 Grand Touring

2007 ENGINE PERFORMANCE On-Board Diagnostic (MZI-3.5) - CX-9

	<ul style="list-style-type: none"> <li>• Verify that the battery is fully charged.</li> <li>• Verify that there is clean sufficient fuel.</li> <li>• Is a concern present?</li> </ul>		
4	<p><b>INSPECT ALL SYSTEM RELATED DEVICES (SENSOR, DAMPER OR REGULATOR) FOR LEAKAGE</b></p> <ul style="list-style-type: none"> <li>• Turn the ignition switch off.</li> <li>• Connect the fuel pump connector.</li> <li>• Turn the ignition switch to the ON position (Engine running).</li> <li>• Check for manifold vacuum at each system related component with a vacuum line.</li> <li>• Turn the ignition switch off.</li> <li>• Wait 10 s.</li> <li>• Turn the ignition switch to the ON position (Engine running).</li> <li>• Run the engine for approx. 10 s.</li> <li>• Turn the ignition switch off.</li> <li>• Remove the vacuum hose on each system device connected to the fuel rail.</li> <li>• Inspect for the presence of fuel in the vacuum line of each device connected to the fuel rail.</li> <li>• Are all vacuum lines for system related devices indicating no fuel present?</li> </ul>	Yes	Go to the next step.
		No	If the vacuum line connected to a component indicates that a fuel leak is present, install a new component. Then go to Step 11.
5	<p><b>INSPECT FUEL PRESSURE</b></p> <ul style="list-style-type: none"> <li>• Turn the ignition switch off.</li> <li>• Relieve the fuel pressure. Refer to the Workshop Manual Fuel System Pressure Release procedure.</li> <li>• Connect the mechanical fuel pressure gauge.</li> <li>• Turn the ignition switch to the ON position (Engine off).</li> </ul>	Yes	Go to Step 9.
		No	Go to the next step.

## 2007 Mazda CX-9 Grand Touring

2007 ENGINE PERFORMANCE On-Board Diagnostic (MZI-3.5) - CX-9

	<ul style="list-style-type: none"> <li>• Pressurize the fuel system. Refer to the Workshop Fuel System for the Fuel System Pressure Release procedure to pressurize the fuel system.</li> <li>• Compare the fuel pressure reading to the Fuel System Specification Chart.</li> <li>• Is the fuel pressure within range?</li> </ul>		
6	<p><b>INSPECT FUEL PUMP GROUND CIRCUIT FOR OPEN CIRCUIT IN WIRING HARNESS</b></p> <p><b>NOTE:</b></p> <ul style="list-style-type: none"> <li>• Refer to the <b>Wiring Diagrams Manual for schematic and connector information.</b></li> <li>• Disconnect the fuel pump connector.</li> <li>• Measure the resistance between fuel pump connector terminal D (wiring harness-side) and body ground.</li> <li>• Is the voltage less than 0.5 ohm?</li> </ul>	Yes	Go to the next step.
		No	Repair or replace suspected part, Then go to Step 11.
7	<p><b>INSPECT FUEL PUMP POWER SUPPLY CIRCUIT FOR OPEN CIRCUIT IN WIRING HARNESS</b></p> <ul style="list-style-type: none"> <li>• Disconnect the fuel pump connector.</li> <li>• Turn the ignition switch to the ON position (Engine off).</li> <li>• Access the PCM and control the FP PID.</li> <li>• Measure the voltage between fuel pump connector terminal B (wiring harness-side) and body ground.</li> <li>• Is the voltage more than 10 V?</li> </ul>	Yes	Go to the next step.
		No	Repair or replace suspected part, Then go to Step 11.
8	<p><b>INSPECT FUEL PRESSURE LEAK</b></p> <p><b>NOTE:</b></p>	Yes	Perform the KOEO self-test. Go to Step 10.

## 2007 Mazda CX-9 Grand Touring

2007 ENGINE PERFORMANCE On-Board Diagnostic (MZI-3.5) - CX-9

	<ul style="list-style-type: none"> <li>• <b>When the fuel pump is commanded off, the fuel pressure may substantially decrease and then stabilize.</b></li> </ul> <p><b>NOTE:</b></p> <ul style="list-style-type: none"> <li>• <b>During output state control, the fuel pump stays commanded on for only approx. 5 s.</b></li> <li>• Connect the mechanical fuel pressure gauge.</li> <li>• Turn the ignition switch to the ON position (Engine off).</li> <li>• Access the PCM and control the FP PID.</li> <li>• Run the fuel pump to obtain maximum fuel pressure.</li> <li>• Command the fuel pump off.</li> <li>• Allow the fuel pressure to stabilize.</li> <li>• Record the stabilized reading.</li> <li>• Monitor the fuel pressure for 1 min.</li> <li>• Does the fuel pressure remain within 34 kPa {255 mmHg, 10.0 inHg} of the recorded reading after 1 min?</li> </ul>	No	Go to the next step.
9	<p><b>INSPECT FUEL INJECTOR OPERATION</b></p> <ul style="list-style-type: none"> <li>• Remove the fuel injector.</li> <li>• Inspect the fuel injector operation.</li> <li>• Is the fuel injector normal?</li> </ul>	Yes	Go to the next step.
		No	Replace the fuel injector, then go to Step 11.
10	<p><b>INSPECT FUEL SUPPLY LINE FOR RESTRICTION</b></p> <p><b>NOTE:</b></p> <ul style="list-style-type: none"> <li>• <b>Observe the Warnings, Cautions, and Notes.</b></li> <li>• Disconnect the fuel supply line at the fuel rail.</li> </ul>	Yes	Replace the fuel pump module. Then go to the next step.

## 2007 Mazda CX-9 Grand Touring

2007 ENGINE PERFORMANCE On-Board Diagnostic (MZI-3.5) - CX-9

	<ul style="list-style-type: none"> <li>• Disconnect the fuel supply line at the fuel pump.</li> <li>• Check the fuel supply line for restriction.</li> <li>• Apply 21-34 kPa {2142-3467 mmHg, 84.34-136.4 inHg} air pressure to the fuel supply line.</li> <li>• Does air flow freely through the line?</li> </ul>	No	Repair the cause of the restriction. Then go to the next step.
11	<b>VERIFY TROUBLESHOOTING OF DTC P0148 HAS BEEN COMPLETED</b> <ul style="list-style-type: none"> <li>• Verify that all disconnected connectors are reconnected.</li> <li>• Turn the ignition switch to the ON position (Engine off).</li> <li>• Clear the DTC from the PCM memory using the M-MDS.</li> <li>• Start the engine and run it at idle.</li> <li>• Retrieve DTCs using the M-MDS.</li> <li>• Is the PENDING CODE for this DTC present?</li> </ul>	Yes	Replace PCM, then go to the next step. (see <b><u>PCM REMOVAL/INSTALLATION [MZI-3.5]</u></b> .)
		No	Go to the next step.
12	<b>VERIFY AFTER REPAIR PROCEDURE</b> <ul style="list-style-type: none"> <li>• Perform "AFTER REPAIR PROCEDURE".</li> </ul> <p>(See <b><u>AFTER REPAIR PROCEDURE [MZI-3.5]</u></b>.)</p> <ul style="list-style-type: none"> <li>• Are any DTC present?</li> </ul>	Yes	Go to the applicable DTC inspection. (See <b><u>DTC TABLE [MZI-3.5]</u></b> .)
		No	Troubleshooting completed.

### DTC P0171, P0174 [MZI-3.5]

#### DTC P0171, P0174 (MZI-3.5) DETECTION CONDITION AND POSSIBLE CAUSES

<b>DTC P0171</b>	<b>P0171: System too lean (RH)</b>
<b>DTC P0174</b>	<b>P0174: System too lean (LH)</b>
<b>DETECTION CONDITION</b>	<ul style="list-style-type: none"> <li>• P0171 indicates that the fuel/air ratio is too lean (RH).</li> <li>• P0174 indicates that the fuel/air ratio is too lean (LH).</li> <li>• The adaptive fuel strategy continuously monitors the fuel delivery hardware.</li> </ul>

## 2007 Mazda CX-9 Grand Touring

2007 ENGINE PERFORMANCE On-Board Diagnostic (MZI-3.5) - CX-9

	The test fails when the adaptive fuel tables reach a rich calibrated limit.
<b>POSSIBLE CAUSE</b>	<p>Fuel System:</p> <ul style="list-style-type: none"> <li>• Damaged or leaking fuel pulse damper</li> <li>• Fuel filter plugged or dirty</li> <li>• Damaged or worn fuel pump</li> <li>• Leaking fuel pump check valve</li> <li>• Leaking/contaminated fuel injectors</li> <li>• Low fuel pressure or running out of fuel</li> <li>• Purge solenoid valve is leaking when the canister is clean</li> <li>• Fuel supply line restricted</li> <li>• Fuel rail pressure sensor bias</li> </ul> <p>Exhaust System:</p> <ul style="list-style-type: none"> <li>• Exhaust leaks in the exhaust manifold gasket or mating gaskets before or near the HO2S</li> </ul> <p>Intake Air System:</p> <ul style="list-style-type: none"> <li>• Air leaks after the MAF sensor</li> <li>• Vacuum leaks</li> <li>• PCV system is leaking or the valve is stuck open</li> <li>• Improperly seated engine oil dipstick</li> <li>• Damaged or contaminated MAF sensor</li> </ul>

### DIAGNOSTIC PROCEDURE

#### DTC P0171, P0174 (MZI-3.5) DIAGNOSTIC PROCEDURE

STEP	INSPECTION		ACTION
1	<b>VERIFY FREEZE FRAME DATA HAS BEEN RECORDED</b>  <ul style="list-style-type: none"> <li>• Has FREEZE FRAME DATA been recorded?</li> </ul>	Yes	Go to the next step.
		No	Record FREEZE FRAME DATA on the repair order, then go to the next step.
2	<b>VERIFY RELATED REPAIR INFORMATION AVAILABILITY</b>  <ul style="list-style-type: none"> <li>• Verify related Service Bulletins and/or on-line repair information availability.</li> <li>• Is any related Service Bulletins</li> </ul>	Yes	Perform repair or diagnosis according to the available Service Bulletins.  <ul style="list-style-type: none"> <li>• If the vehicle is not repaired, go to the next step.</li> </ul>
		No	Go to the next step.

## 2007 Mazda CX-9 Grand Touring

2007 ENGINE PERFORMANCE On-Board Diagnostic (MZI-3.5) - CX-9

	available?		
3	<p><b>VERIFY RELATED PENDING CODE OR STORED DTCS</b></p> <ul style="list-style-type: none"> <li>• Turn the ignition switch off then to the ON position (Engine off).</li> <li>• Verify related PENDING CODE or stored DTCs.</li> <li>• Are any DTCs present other than the following:                             <ul style="list-style-type: none"> <li>○ P0171, P0174, P2195 or P2197?</li> </ul> </li> </ul>	Yes	Go to the appropriate DTC troubleshooting procedures. (See <b><u>DTC TABLE [MZI-3.5]</u></b> .)
		No	Go to the next step.
4	<p><b>PERFORM VISUAL INSPECTION ON INTAKE AIR SYSTEM AND ALL VACUUM HOSES</b></p> <ul style="list-style-type: none"> <li>• Turn the ignition switch off.</li> <li>• Check the intake air system for leaks, obstructions, and damage.</li> <li>• Inspect the entire length of all the vacuum hoses for:                             <ul style="list-style-type: none"> <li>○ Proper connections</li> <li>○ Damage or cracks</li> <li>○ Damaged or cracked vacuum vacuum hose joint</li> </ul> </li> <li>• Verify the integrity of the positive crankcase ventilation system.</li> <li>• Verify that the PCV valve part number is correct.</li> <li>• Is a concern present?</li> </ul>	Yes	Repair if necessary. Then go to Step 7.
		No	Go to the next step.
5	<p><b>INSPECT FOR PRESENCE OF VACUUM LEAK</b></p> <p><b>NOTE:</b></p> <ul style="list-style-type: none"> <li>• Fuel trim values at idle are more sensitive to a vacuum leak. The vacuum leak (unmetered air) represents a larger portion of the total air flow at idle than at part throttle.</li> <li>• The BARO PID is not a commended PID to monitor when diagnosing a vacuum leak. BARO is calculated during high</li> </ul>	Yes	No vacuum leak is present. Go to Step 8.

## 2007 Mazda CX-9 Grand Touring

2007 ENGINE PERFORMANCE On-Board Diagnostic (MZI-3.5) - CX-9

**engine load, when the vacuum leak represents a small portion of the total air flow**

- **When calculating the total fuel correction in the following steps, if LONGFT1 equals +13% and SHRTFT1 equals +23%, the total fuel correction for bank 1 equals +36%. If LONGFT2 equals +24% and SHRTFT2 equals -3% the total fuel correction for bank 2 equals +21%.**
- **If the freeze frame ECT PID is available, stabilize the engine at the temperature recorded by the freeze frame ECT PID. If the freeze frame ECT PID is not available, maintain the engine coolant temperature between 82-101 °C {180-215 °F} and the intake air temperature at less than 46 °C {115°F}.**
- Turn the ignition switch to the ON position (Engine running).
- Access the PCM and monitor the ECT, CHT and IAT PIDs.
- Access the PCM and monitor the LONGFT1, SHRTFT1, LONGFT2 and SHRTFT2 PIDs.
- Allow the engine to stabilize at the temperature necessary to recreate the concern.
- Add and record the LONGFT PID value to the SHRTFT PID value for each bank, correction at idle.
- Increase the engine speed to 2,500 rpm for 10 s. Record the LONGFT1, SHRTFT1, LONGFT2, and system SHRTFT2 PID values.
- Add and record the LONGFT PID value to the SHRTFT PID value for each bank, correction at 2,500 rpm.
- Is the total fuel correction value difference between idle and 2,500

No Go to the next step.



## 2007 Mazda CX-9 Grand Touring

2007 ENGINE PERFORMANCE On-Board Diagnostic (MZI-3.5) - CX-9

	rpm less than 15%?		
6	<p><b>LOCATE VACUUM LEAK</b></p> <p><b>CAUTION:</b></p> <ul style="list-style-type: none"> <li>Do not clamp or pinch a hard plastic hose. Use a vacuum cap or equivalent to restrict the hose.</li> </ul> <p><b>NOTE:</b></p> <ul style="list-style-type: none"> <li>Restricting the EVAP vapor hose while the EVAP emission canister is purging may shift the SHRTFT. Perform a visual inspection if necessary.</li> <li>When monitoring for a decrease in the SHRTFT PIDs in the following steps, if SHRTFT1 equals +15% and the hose is restricted, SHRTFT1 decreases to -7%. The total decrease in the SHRTFT PIDs equals 22%.</li> <li>Locate the vacuum hose joint for the intake air and PCV systems.</li> <li>Access the PCM and monitor the SHRTFT1 and SHRTFT2 PIDs.</li> <li>Restrict the vacuum lines one at a time for 30 s. If a vacuum leak in the intake is present, the SHRTFT PID values decrease as the hose is restricted.</li> <li>Is the decrease in the SHRTFT PIDs more than 15% when one of the vacuum hoses is restricted?</li> </ul>	Yes	Repair if necessary. Then go to the next step.
		No	Inspect the intake air system for a vacuum leak in the intake manifold or intake gaskets. Repair if necessary. Then go to the next step.
7	<p><b>VACUUM LEAK REPAIR VERIFICATION</b></p> <p><b>NOTE:</b></p> <ul style="list-style-type: none"> <li>If the freeze frame ECT PID is available, stabilize the engine at the temperature recorded by the freeze frame ECT PID. If the freeze frame ECT PID is not available, maintain the engine coolant temperature between 82-</li> </ul>	Yes	Reset the keep alive memory. Then go to Step 13.

## 2007 Mazda CX-9 Grand Touring

2007 ENGINE PERFORMANCE On-Board Diagnostic (MZI-3.5) - CX-9

	<p><b>101 °C {180-215 °F} and the intake air temperature less than 46 °C {115 °F}.</b></p> <ul style="list-style-type: none"> <li>• Access the PCM and monitor the SHRTFT1 and SHRTFT2 PIDs.</li> <li>• Allow the engine to stabilize at the temperature necessary to recreate the concern.</li> <li>• Record the SHRTFT1 and SHRTFT2 PID values.</li> <li>• Turn the ignition switch off.</li> <li>• Repair the vacuum leak.</li> <li>• Turn the ignition switch to the ON position (Engine running).</li> <li>• Allow the engine to stabilize at the temperature necessary to recreate the concern.</li> <li>• Access the PCM and monitor the SHRTFT1 and SHRTFT2 PIDs.</li> <li>• Compare the recorded SHRTFT PID values, prior to the no vacuum leak repair, to the current SHRTFT PID values.</li> <li>• Is the decrease in the SHRTFT PIDs more than 15%?</li> </ul>	No	A vacuum leak is still present. Go to Step 6.
8	<p><b>INSPECT FUEL PRESSURE</b></p> <p><b>WARNING:</b></p> <ul style="list-style-type: none"> <li>• <b>Fuel line spills and leakage are dangerous. Fuel can ignite and cause serious injuries or death. Fuel can also irritate skin and eyes. To prevent this, always complete the "BEFORE REPAIR PROCEDURE".</b></li> </ul> <p><b>NOTE:</b></p> <ul style="list-style-type: none"> <li>• For vehicle specific fuel pressure ranges, refer to the "<b><u>FUEL LINE PRESSURE INSPECTION</u></b>".</li> <li>• Remove the jumper wire(s).</li> </ul>	Yes	Go to Step 10.

## 2007 Mazda CX-9 Grand Touring

2007 ENGINE PERFORMANCE On-Board Diagnostic (MZI-3.5) - CX-9

	<ul style="list-style-type: none"> <li>• Connect the HO2S connector.</li> <li>• Relieve the fuel pressure.</li> <li>• Connect the mechanical fuel pressure gauge.</li> <li>• Pressurize the fuel system.</li> <li>• Turn the ignition switch to the ON position (Engine running).</li> <li>• Allow the fuel pressure to stabilize.</li> <li>• Turn the ignition switch off.</li> <li>• Access the PCM and control the FP PID.</li> <li>• Run the fuel pump to obtain maximum fuel pressure.</li> <li>• Is the fuel pressure within the range for the vehicle being diagnosed?</li> </ul>	No	Go to the next step.
9	<b>INSPECT FUEL LINE FROM FUEL PUMP TO FUEL DELIVERY PIPE</b> <ul style="list-style-type: none"> <li>• Visually inspect fuel line for any leakage.</li> <li>• Is fuel leakage found?</li> </ul>	Yes	Replace suspected fuel line. Then go to Step 13.
		No	Inspect the low-pressure side fuel filter for the following: <ul style="list-style-type: none"> <li>• Foreign materials or stain inside fuel filter. Perform the following actions as a result.</li> <li>• If foreign material or staining is found inside the fuel filter (low-pressure side), clean the fuel tank and filter.</li> <li>• If normal, replace fuel pump unit.</li> </ul> Then go to Step 13.
10	<b>INSPECT FUEL INJECTOR OPERATION</b> <ul style="list-style-type: none"> <li>• Remove fuel injector.</li> <li>• Inspect the injector operation.</li> <li>• Is the fuel injector normal?</li> </ul>	Yes	Go to the next step.
		No	Replace the fuel injector, then go to Step 13.
11	<b>INSPECT FRONT HO2S OUTPUT VOLTAGE</b> <ul style="list-style-type: none"> <li>• Visually inspect the HO2S circuit</li> </ul>	Yes	Go to the next step.

## 2007 Mazda CX-9 Grand Touring

2007 ENGINE PERFORMANCE On-Board Diagnostic (MZI-3.5) - CX-9

	<p>for exposed wiring, contamination, corrosion and correct assembly. Repair if necessary.</p> <ul style="list-style-type: none"> <li>• Measure the voltage between HO2S terminal B and D on the component side.</li> <li>• Increase the engine speed to 2,000 rpm for 3 min.</li> <li>• Turn the ignition switch to the ON position (Engine running).</li> <li>• Monitor the signal voltage.</li> <li>• Is the voltage more than 0.5 V at any time during the engine running?</li> </ul>	No	Replace the HO2S. Then go to Step 13.
12	<p><b>PERFORM THOROUGH WIGGLE TEST ON HO2S WIRING HARNESS</b></p> <ul style="list-style-type: none"> <li>• Turn the ignition switch off.</li> <li>• Connect the HO2S connector.</li> <li>• Turn the ignition switch to the ON position (Engine running).</li> <li>• Verify that the engine is at normal operating temperature.</li> <li>• Access the PCM and monitor the HO2S signal PID.</li> <li>• Wiggle, shake, and bend small sections of the wiring harness while working from the sensor to the PCM.</li> <li>• While monitoring the HO2S PID, does the HO2S stop switching?</li> </ul>	Yes	Isolate the concern and repair if necessary. Then go to the next step.
		No	Go to the next step.
13	<p><b>VERIFY TROUBLESHOOTING OF DTC P0171, P0174 HAS BEEN COMPLETED</b></p> <ul style="list-style-type: none"> <li>• Verify that all disconnected connectors are reconnected.</li> <li>• Turn the ignition switch to the ON position (Engine off).</li> <li>• Clear the DTC from the PCM memory using the M-MDS.</li> <li>• Start the engine and run it at idle.</li> <li>• Retrieve DTCs using the M-MDS.</li> </ul>	Yes	Replace PCM, then go to the next step. (see <b>PCM REMOVAL/INSTALLATION [MZI-3.5]</b> .)
		No	Go to the next step.

## 2007 Mazda CX-9 Grand Touring

2007 ENGINE PERFORMANCE On-Board Diagnostic (MZI-3.5) - CX-9

	<ul style="list-style-type: none"> <li>Is the PENDING CODE for this DTC present?</li> </ul>		
14	<p><b>VERIFY AFTER REPAIR PROCEDURE</b></p> <ul style="list-style-type: none"> <li>Perform "AFTER REPAIR PROCEDURE".</li> </ul> <p>(See <b><u>AFTER REPAIR PROCEDURE [MZI-3.5].</u></b>)</p> <ul style="list-style-type: none"> <li>Are any DTC present?</li> </ul>	Yes	Go to the applicable DTC inspection. (See <b><u>DTC TABLE [MZI-3.5].</u></b> )
		No	Troubleshooting completed.

### DTC P0172, P0175 [MZI-3.5]

#### DTC P0172, P0175 (MZI-3.5) DETECTION CONDITION AND POSSIBLE CAUSES

<b>DTC P0172</b>	<b>P0172: System too rich (RH)</b>
<b>DTC P0175</b>	<b>P0175: System too rich (LH)</b>
<b>DETECTION CONDITION</b>	<ul style="list-style-type: none"> <li>P0172 indicates that the fuel/air ratio is too rich (RH).</li> <li>P0175 indicates that the fuel/air ratio is too rich (LH).</li> <li>The adaptive fuel strategy continuously monitors the fuel delivery hardware. The test fails when the adaptive fuel tables reach a rich calibrated limit.</li> </ul>
<b>POSSIBLE CAUSE</b>	<p>Fuel System:</p> <ul style="list-style-type: none"> <li>Damaged or leaking fuel pulse damper</li> <li>Leaking fuel injectors</li> <li>Fuel return line restricted</li> <li>Fuel rail pressure sensor bias</li> <li>Purge solenoid valve is leaking when the canister is full</li> </ul> <p>Base engine:</p> <ul style="list-style-type: none"> <li>Engine oil contamination</li> </ul> <p>Intake Air System</p> <ul style="list-style-type: none"> <li>Damaged or contaminated MAF sensor</li> </ul>

#### DIAGNOSTIC PROCEDURE

##### DTC P0172, P0175 (MZI-3.5) DIAGNOSTIC PROCEDURE

STEP	INSPECTION		ACTION
1	<b>VERIFY FREEZE FRAME DATA</b>	Yes	Go to the next step.

## 2007 Mazda CX-9 Grand Touring

2007 ENGINE PERFORMANCE On-Board Diagnostic (MZI-3.5) - CX-9

	<p><b>HAS BEEN RECORDED</b></p> <ul style="list-style-type: none"> <li>• Has FREEZE FRAME DATA been recorded?</li> </ul>	No	Record FREEZE FRAME DATA on the repair order, then go to the next step.
2	<p><b>VERIFY RELATED REPAIR INFORMATION AVAILABILITY</b></p> <ul style="list-style-type: none"> <li>• Verify related Service Bulletins and/or on-line repair information availability.</li> <li>• Is any related Service Bulletins available?</li> </ul>	Yes	<p>Perform repair or diagnosis according to the available Service Bulletins.</p> <ul style="list-style-type: none"> <li>• If the vehicle is not repaired, go to the next step.</li> </ul>
		No	Go to the next step.
3	<p><b>VERIFY RELATED PENDING CODE OR STORED DTCS</b></p> <ul style="list-style-type: none"> <li>• Turn the ignition switch off then to the ON position (Engine off).</li> <li>• Verify related PENDING CODE or stored DTCs.</li> <li>• Are any DTCs present other than the following:                             <ul style="list-style-type: none"> <li>◦ P0172, P0175, P2196 or P2198?</li> </ul> </li> </ul>	Yes	Go to the appropriate DTC troubleshooting procedures. (See <b><u>DTC TABLE [MZI-3.5]</u></b> .)
		No	Go to the next step.
4	<p><b>INSPECT ENTIRE INTAKE AIR SYSTEM FOR DEBRIS, BLOCKAGE OR OTHER DAMAGE</b></p> <ul style="list-style-type: none"> <li>• Check the intake air system for obstructions, restrictions, and damage.</li> <li>• Check the throttle plate for obstructions or sludge.</li> <li>• Check the air filter element and housing for blockage.</li> <li>• Is a concern present?</li> </ul>	Yes	Repair if necessary. Then go to Step 9.
		No	Go to the next step.
5	<p><b>INSPECT FUEL PRESSURE</b></p> <p><b>WARNING:</b></p> <ul style="list-style-type: none"> <li>• Fuel line spills and leakage are dangerous. Fuel can ignite and cause serious injuries or death. Fuel can also irritate skin and eyes. To prevent this, always complete the "BEFORE REPAIR PROCEDURE".</li> </ul>	Yes	Go to the next step.

## 2007 Mazda CX-9 Grand Touring

2007 ENGINE PERFORMANCE On-Board Diagnostic (MZI-3.5) - CX-9

<p><b>NOTE:</b></p> <ul style="list-style-type: none"> <li>• For vehicle specific fuel pressure ranges, refer to the "<b><u>FUEL LINE PRESSURE INSPECTION</u></b>".</li> <li>• Remove the jumper wire(s).</li> <li>• Connect the HO2S connector.</li> <li>• Relieve the fuel pressure.</li> <li>• Connect the mechanical fuel pressure gauge</li> <li>• Pressurize the fuel system.</li> <li>• Turn the ignition switch to the ON position (Engine running).</li> <li>• Allow the fuel pressure to stabilize.</li> <li>• Turn the ignition switch off.</li> <li>• Turn the ignition switch to the ON position (Engine running).</li> <li>• Access the PCM and control the FP PID.</li> <li>• Run the fuel pump to obtain maximum fuel pressure.</li> <li>• Is the fuel pressure within the range for the vehicle being diagnosed?</li> </ul>	No	Replace the fuel pump unit. Then go to Step 9.	
6	<b>INSPECT FUEL INJECTOR OPERATION</b>	Yes	Go to the next step.
	<ul style="list-style-type: none"> <li>• Remove fuel injector.</li> <li>• Inspect the injector operation.</li> <li>• Is the fuel injector normal?</li> </ul>	No	Replace the fuel injector. Then go to Step 9.
7	<b>INSPECT HO2S OUTPUT VOLTAGE</b>	Yes	Go to the next step.
	<ul style="list-style-type: none"> <li>• Visually inspect the HO2S circuit for exposed wiring, contamination, corrosion and correct assembly. Repair if necessary.</li> <li>• Measure the voltage between HO2S terminal B and D on the component side.</li> </ul>	No	Replace the HO2S. Then go to Step 9.

## 2007 Mazda CX-9 Grand Touring

2007 ENGINE PERFORMANCE On-Board Diagnostic (MZI-3.5) - CX-9

	<ul style="list-style-type: none"> <li>• Increase the engine speed to 2,000 rpm for 3 min.</li> <li>• Turn the ignition switch to the ON position (Engine running).</li> <li>• Monitor the signal voltage.</li> <li>• Is the voltage more than 0.5 V at any time during the engine running?</li> </ul>		
8	<p><b>PERFORM THOROUGH WIGGLE TEST ON HO2S WIRING HARNESS</b></p> <ul style="list-style-type: none"> <li>• Turn the ignition switch off.</li> <li>• Connect the HO2S connector.</li> <li>• Turn the ignition switch to the ON position (Engine running).</li> <li>• Verify that the engine is at normal operating temperature.</li> <li>• Access the PCM and monitor the HO2S signal PID.</li> <li>• Wiggle, shake, and bend small sections of the wiring harness while working from the sensor to the PCM.</li> <li>• While monitoring the HO2S PID, does the HO2S stop switching?</li> </ul>	Yes	Isolate the concern and repair if necessary. Then go to the next step.
		No	Go to the next step.
9	<p><b>VERIFY TROUBLESHOOTING OF DTC P0172, P0175 HAS BEEN COMPLETED</b></p> <ul style="list-style-type: none"> <li>• Verify that all disconnected connectors are reconnected.</li> <li>• Turn the ignition switch to the ON position (Engine off).</li> <li>• Clear the DTC from the PCM memory using the M-MDS.</li> <li>• Start the engine and run it at idle.</li> <li>• Retrieve DTCs using the M-MDS.</li> <li>• Is the PENDING CODE for this DTC present?</li> </ul>	Yes	Replace the PCM, then go to the next step. (see <b><u>PCM REMOVAL/INSTALLATION [MZI-3.5]</u></b> .)
		No	Go to the next step.
10	<p><b>VERIFY AFTER REPAIR PROCEDURE</b></p>	Yes	Go to the applicable DTC inspection. (See <b><u>DTC TABLE [MZI-3.5]</u></b> .)



## 2007 Mazda CX-9 Grand Touring

2007 ENGINE PERFORMANCE On-Board Diagnostic (MZI-3.5) - CX-9

<ul style="list-style-type: none"><li>• Perform "AFTER REPAIR PROCEDURE".</li></ul> <p>(See <b><u>AFTER REPAIR PROCEDURE [MZI-3.5].</u></b>)</p> <ul style="list-style-type: none"><li>• Are any DTC present?</li></ul>	No	Troubleshooting completed.
---	----	----------------------------

### DTC P0201 [MZI-3.5]

#### DTC P0201 (MZI-3.5) DETECTION CONDITION AND POSSIBLE CAUSES

<b>DTC P0201</b>	<b>Injector circuit/open-cylinder No.1</b>
<b>DETECTION CONDITION</b>	<ul style="list-style-type: none"><li>• The CCM monitors the operation of the fuel injector drivers in the PCM. The test if the fuel injector circuitry is inoperative.</li></ul>
<b>POSSIBLE CAUSE</b>	<ul style="list-style-type: none"><li>• Fuel injector No.1 malfunction</li><li>• Connector or terminal malfunction</li><li>• Open circuit between fuel pump relay and fuel injector No.1 terminal B</li><li>• Open circuit between fuel injector No.1 terminal A and PCM terminal 2BJ</li></ul>

## 2007 Mazda CX-9 Grand Touring

2007 ENGINE PERFORMANCE On-Board Diagnostic (MZI-3.5) - CX-9

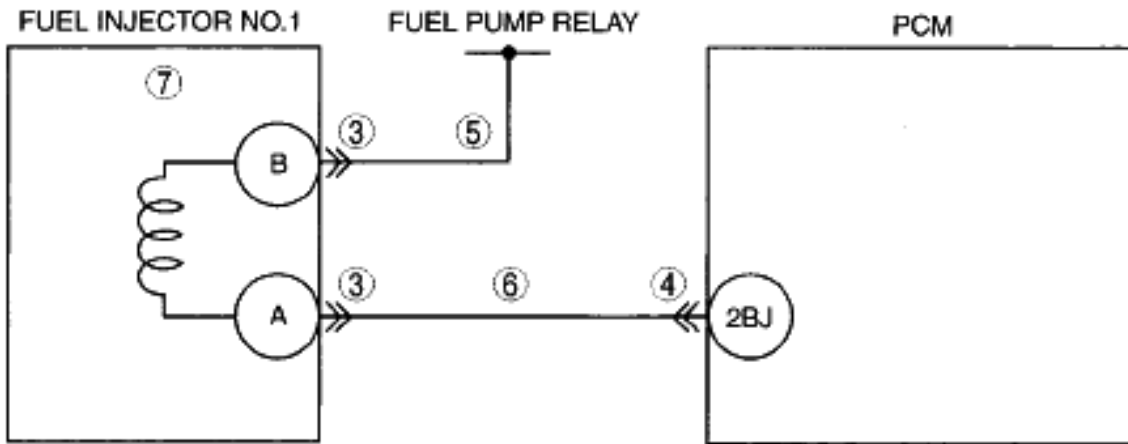

FUEL INJECTOR NO.1  
WIRING HARNESS-SIDE CONNECTOR

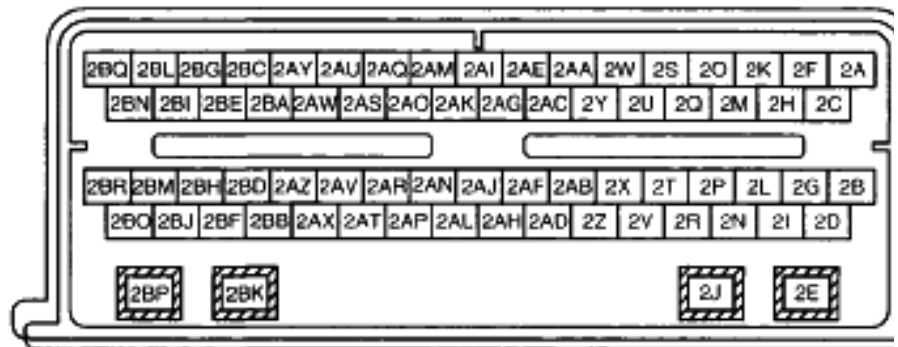

### DIAGNOSTIC PROCEDURE

#### DTC P0201 (MZI-3.5) DIAGNOSTIC PROCEDURE

STEP	INSPECTION		ACTION
1	<b>VERIFY FREEZE FRAME DATA HAS BEEN RECORDED</b>  • Has FREEZE FRAME DATA been recorded?	Yes	Go to the next step.
		No	Record FREEZE FRAME DATA on the repair order, then go to the next step.
2	<b>VERIFY RELATED REPAIR INFORMATION AVAILABILITY</b>  • Verify related Service Bulletins availability.	Yes	Perform repair or diagnosis according to available Service Bulletins.  • If vehicle is not repaired, go to the next step.

## 2007 Mazda CX-9 Grand Touring

2007 ENGINE PERFORMANCE On-Board Diagnostic (MZI-3.5) - CX-9

	<ul style="list-style-type: none"> <li>• Is any related Service Bulletins available?</li> </ul>	No	Go to the next step.
3	<b>INSPECT FUEL INJECTOR NO.1 CONNECTOR FOR POOR CONNECTION</b> <ul style="list-style-type: none"> <li>• Turn the ignition switch off.</li> <li>• Disconnect the fuel injector No.1 connector.</li> <li>• Inspect for poor connection (such as damaged/pulled-out pins, corrosion).</li> <li>• Are there malfunction?</li> </ul>	Yes	Repair or replace suspected part, then go to Step 8.
		No	Go to the next step.
4	<b>INSPECT PCM CONNECTOR FOR POOR CONNECTION</b> <ul style="list-style-type: none"> <li>• Turn the ignition switch off.</li> <li>• Disconnect the PCM connector.</li> <li>• Inspect for poor connection (such as damaged/pulled-out pins, corrosion).</li> <li>• Is there malfunction?</li> </ul>	Yes	Repair or replace suspected part, then go to Step 8.
		No	Go to the next step.
5	<b>INSPECT FUEL INJECTOR NO.1 POWER SUPPLY CIRCUIT FOR OPEN CIRCUIT</b> <ul style="list-style-type: none"> <li>• Turn the ignition switch to the ON position (Engine off).</li> <li>• Measure the voltage between fuel injector No. 1 connector terminal B and body ground.</li> <li>• Is the voltage <b>B+</b> ?</li> </ul>	Yes	Go to the next step.
		No	Repair or replace suspected part, then go to Step 8.
6	<b>INSPECT FUEL INJECTOR NO.1 SIGNAL CIRCUIT FOR OPEN CIRCUIT</b> <ul style="list-style-type: none"> <li>• Inspect continuity between fuel injector No.1 terminal A (wiring harness-side) and PCM terminal 2BJ (wiring harness-side).</li> <li>• Is there continuity?</li> </ul>	Yes	Go to the next step.
		No	Repair or replace suspected part, then go to Step 8.
7	<b>INSPECT FUEL INJECTOR NO.1</b>	Yes	Replace the fuel injector No.1, then go to the next step.

## 2007 Mazda CX-9 Grand Touring

2007 ENGINE PERFORMANCE On-Board Diagnostic (MZI-3.5) - CX-9

	<ul style="list-style-type: none"> <li>Inspect the fuel injector No. 1.</li> </ul> <p>(see <b><u>FUEL INJECTOR INSPECTION [MZI-3.5]</u></b> .)</p> <ul style="list-style-type: none"> <li>Is there any malfunction?</li> </ul>	No	Go to the next step.
8	<p><b>VERIFY TROUBLESHOOTING OF DTC P0201 HAS BEEN COMPLETED</b></p> <ul style="list-style-type: none"> <li>Verify that all disconnected connectors reconnected.</li> <li>Clear DTC from memory using M-MDS.</li> <li>Start the engine.</li> <li>Perform the "KOEO/KOER self-test"</li> </ul> <p>(See <b><u>KOEO/KOER SELF TEST [MZI-3.5]</u></b>.)</p> <ul style="list-style-type: none"> <li>Is same DTC present?</li> </ul>	Yes	Replace the PCM, then go to the next step.
		No	Go to the next step.
9	<p><b>VERIFY AFTER REPAIR PROCEDURE</b></p> <ul style="list-style-type: none"> <li>Perform the "AFTER REPAIR PROCEDURE".</li> </ul> <p>(See <b><u>AFTER REPAIR PROCEDURE [MZI-3.5]</u></b>.)</p> <ul style="list-style-type: none"> <li>Are any DTCs present?</li> </ul>	Yes	Go to the applicable DTC inspection. (See <b><u>DTC TABLE [MZI-3.5]</u></b> .)
		No	Troubleshooting completed.

### DTC P0202 [MZI-3.5]

#### DTC P0202 (MZI-3.5) DETECTION CONDITION AND POSSIBLE CAUSES

DTC P0202	Injector circuit/open-cylinder No.2
<b>DETECTION CONDITION</b>	<ul style="list-style-type: none"> <li>The CCM monitors the operation of the fuel injector drivers in the PCM. The test if the fuel injector circuitry is inoperative.</li> </ul>
<b>POSSIBLE CAUSE</b>	<ul style="list-style-type: none"> <li>Fuel injector No.2 malfunction</li> <li>Connector or terminal malfunction</li> <li>Open circuit between fuel pump relay and fuel injector No.2 terminal B</li> <li>Open circuit between fuel injector No.2 terminal A and PCM terminal 2BM</li> </ul>

## 2007 Mazda CX-9 Grand Touring

2007 ENGINE PERFORMANCE On-Board Diagnostic (MZI-3.5) - CX-9

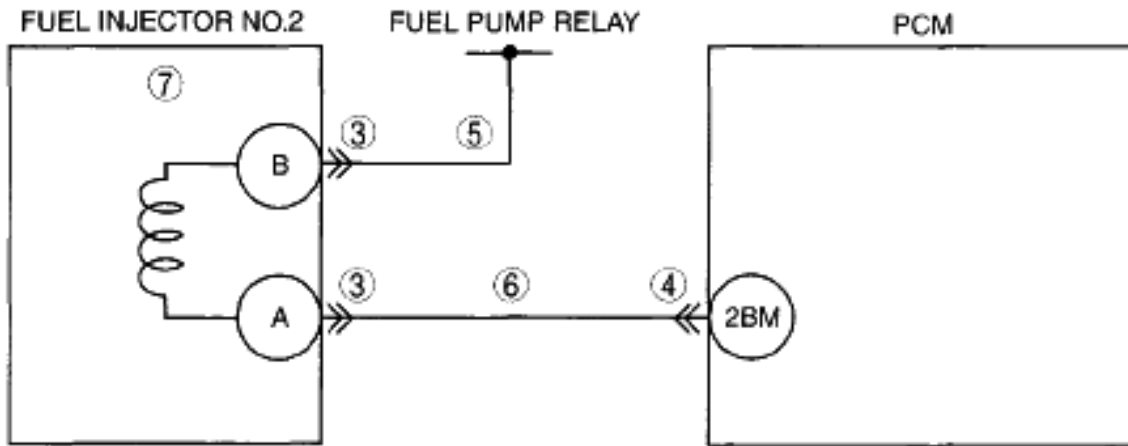

PCM  
WIRING HARNESS-SIDE CONNECTOR

FUEL INJECTOR NO.2  
WIRING HARNESS-SIDE CONNECTOR

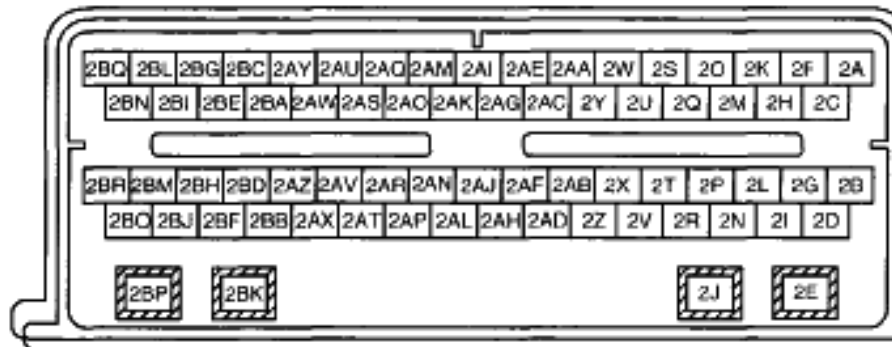

### DIAGNOSTIC PROCEDURE

#### DTC P0202 (MZI-3.5) DIAGNOSTIC PROCEDURE

STEP	INSPECTION		ACTION
1	<b>VERIFY FREEZE FRAME DATA HAS BEEN RECORDED</b> <ul style="list-style-type: none"> <li>Has FREEZE FRAME DATA been recorded?</li> </ul>	Yes	Go to the next step.
		No	Record FREEZE FRAME DATA on the repair order, then go to the next step.
2	<b>VERIFY RELATED REPAIR INFORMATION AVAILABILITY</b> <ul style="list-style-type: none"> <li>Verify related Service Bulletins availability.</li> </ul>	Yes	Perform repair or diagnosis according to available Service Bulletins.
		No	<ul style="list-style-type: none"> <li>If vehicle is not repaired, go to the next step.</li> </ul>

## 2007 Mazda CX-9 Grand Touring

2007 ENGINE PERFORMANCE On-Board Diagnostic (MZI-3.5) - CX-9

	<ul style="list-style-type: none"> <li>Is any related Service Bulletins available?</li> </ul>	No	Go to the next step.
3	<b>INSPECT FUEL INJECTOR NO.2 CONNECTOR FOR POOR CONNECTION</b> <ul style="list-style-type: none"> <li>Turn the ignition switch off.</li> <li>Disconnect the fuel injector No.2 connector.</li> <li>Inspect for poor connection (such as damaged/pulled-out pins, corrosion).</li> <li>Are there malfunction?</li> </ul>	Yes	Repair or replace suspected part, then go to Step 8.
		No	Go to the next step.
4	<b>INSPECT PCM CONNECTOR FOR POOR CONNECTION</b> <ul style="list-style-type: none"> <li>Turn the ignition switch off.</li> <li>Disconnect the PCM connector.</li> <li>Inspect for poor connection (such as damaged/pulled-out pins, corrosion).</li> <li>Is there malfunction?</li> </ul>	Yes	Repair or replace suspected part, then go to Step 8.
		No	Go to the next step.
5	<b>INSPECT FUEL INJECTOR NO.2 POWER SUPPLY CIRCUIT FOR OPEN CIRCUIT</b> <ul style="list-style-type: none"> <li>Turn the ignition switch to the ON position (Engine off).</li> <li>Measure the voltage between fuel injector No.2 connector terminal B and body ground.</li> <li>Is the voltage <b>B+</b> ?</li> </ul>	Yes	Go to the next step.
		No	Repair or replace suspected part, then go to Step 8.
6	<b>INSPECT FUEL INJECTOR NO.2 SIGNAL CIRCUIT FOR OPEN CIRCUIT</b> <ul style="list-style-type: none"> <li>Inspect continuity between fuel injector No.2 terminal A (wiring harness-side) and PCM terminal 2BM (wiring harness-side).</li> <li>Is there continuity?</li> </ul>	Yes	Go to the next step.
		No	Repair or replace suspected part, then go to Step 8.
7	<b>INSPECT FUEL INJECTOR NO.2</b>	Yes	Replace the fuel injector No.2, then go to the next step.

## 2007 Mazda CX-9 Grand Touring

2007 ENGINE PERFORMANCE On-Board Diagnostic (MZI-3.5) - CX-9

	<ul style="list-style-type: none"> <li>Inspect the fuel injector No.2.</li> </ul> <p>(see <b><u>FUEL INJECTOR INSPECTION [MZI-3.5]</u></b> .)</p> <ul style="list-style-type: none"> <li>Is there any malfunction?</li> </ul>	No	Go to the next step.
8	<p><b>VERIFY TROUBLESHOOTING OF DTC P0202 HAS BEEN COMPLETED</b></p> <ul style="list-style-type: none"> <li>Verify that all disconnected connectors reconnected.</li> <li>Clear DTC from memory using M-MDS.</li> <li>Start the engine.</li> <li>Perform the "KOEO/KOER self-test"</li> </ul> <p>(See <b><u>KOEO/KOER SELF TEST [MZI-3.5]</u></b>.)</p> <ul style="list-style-type: none"> <li>Is same DTC present?</li> </ul>	Yes	Replace the PCM, then go to the next step.
		No	Go to the next step.
9	<p><b>VERIFY AFTER REPAIR PROCEDURE</b></p> <ul style="list-style-type: none"> <li>Perform the "AFTER REPAIR PROCEDURE".</li> </ul> <p>(See <b><u>AFTER REPAIR PROCEDURE [MZI-3.5]</u></b>.)</p> <ul style="list-style-type: none"> <li>Are any DTCs present?</li> </ul>	Yes	Go to the applicable DTC inspection. (See <b><u>DTC TABLE [MZI-3.5]</u></b> .)
		No	Troubleshooting completed.

### DTC P0203 [MZI-3.5]

#### DTC P0203 (MZI-3.5) DETECTION CONDITION AND POSSIBLE CAUSES

<b>DTC P0203</b>	<b>Injector circuit/open-cylinder No.3</b>
<b>DETECTION CONDITION</b>	<ul style="list-style-type: none"> <li>The CCM monitors the operation of the fuel injector drivers in the PCM. The test if the fuel injector circuitry is inoperative.</li> </ul>
<b>POSSIBLE CAUSE</b>	<ul style="list-style-type: none"> <li>Fuel injector No.3 malfunction</li> <li>Connector or terminal malfunction</li> <li>Open circuit between fuel pump relay and fuel injector No.3 terminal B</li> <li>Open circuit between fuel injector No.3 terminal A and PCM terminal 2BF</li> </ul>

## 2007 Mazda CX-9 Grand Touring

2007 ENGINE PERFORMANCE On-Board Diagnostic (MZI-3.5) - CX-9

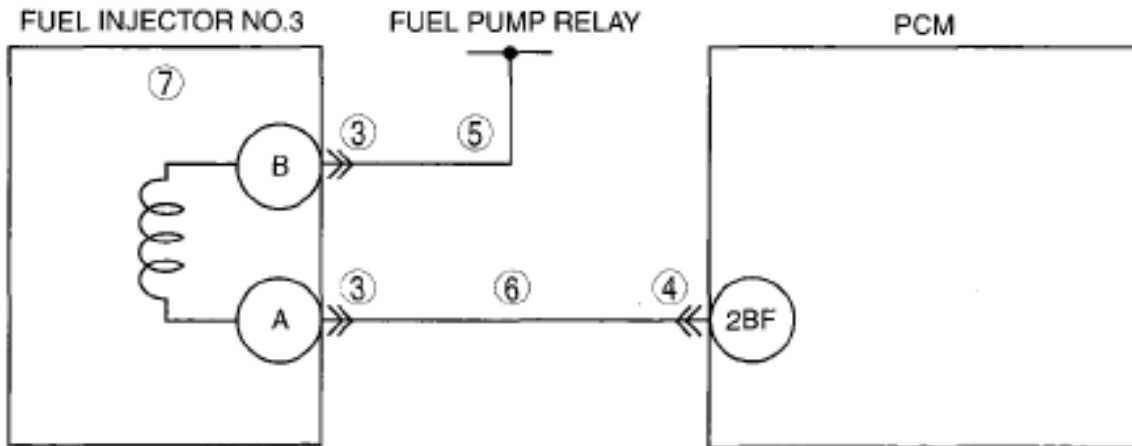

PCM  
WIRING HARNESS-SIDE CONNECTOR

FUEL INJECTOR NO.3  
WIRING HARNESS-SIDE CONNECTOR

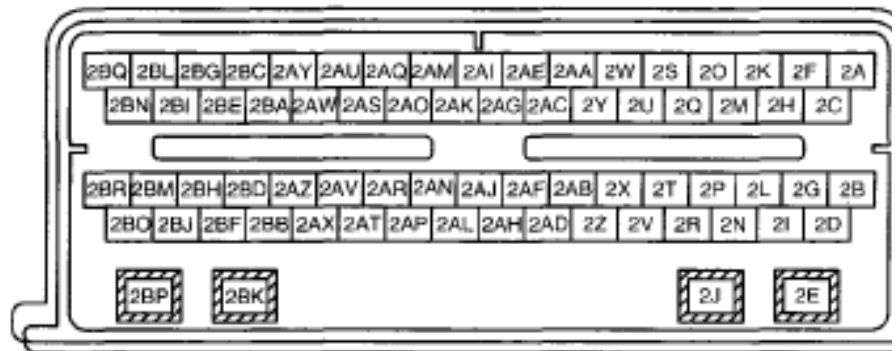

### DIAGNOSTIC PROCEDURE

#### DTC P0203 (MZI-3.5) DIAGNOSTIC PROCEDURE

STEP	INSPECTION		ACTION
1	<b>VERIFY FREEZE FRAME DATA HAS BEEN RECORDED</b>  • Has FREEZE FRAME DATA been recorded?	Yes	Go to the next step.
		No	Record FREEZE FRAME DATA on the repair order, then go to the next step.
2	<b>VERIFY RELATED REPAIR INFORMATION AVAILABILITY</b>  • Verify related Service Bulletins availability.	Yes	Perform repair or diagnosis according to available Service Bulletins.  • If vehicle is not repaired, go to the next step.



## 2007 Mazda CX-9 Grand Touring

2007 ENGINE PERFORMANCE On-Board Diagnostic (MZI-3.5) - CX-9

	<ul style="list-style-type: none"> <li>• Is any related Service Bulletins available?</li> </ul>	No	Go to the next step.
3	<b>INSPECT FUEL INJECTOR NO.3 CONNECTOR FOR POOR CONNECTION</b> <ul style="list-style-type: none"> <li>• Turn the ignition switch off.</li> <li>• Disconnect the fuel injector No.3 connector.</li> <li>• Inspect for poor connection (such as damaged/pulled-out pins, corrosion).</li> <li>• Are there malfunction?</li> </ul>	Yes	Repair or replace suspected part, then go to Step 8.
		No	Go to the next step.
4	<b>INSPECT PCM CONNECTOR FOR POOR CONNECTION</b> <ul style="list-style-type: none"> <li>• Turn the ignition switch off.</li> <li>• Disconnect the PCM connector.</li> <li>• Inspect for poor connection (such as damaged/pulled-out pins, corrosion).</li> <li>• Is there malfunction?</li> </ul>	Yes	Repair or replace suspected part, then go to Step 8.
		No	Go to the next step.
5	<b>INSPECT FUEL INJECTOR NO.3 POWER SUPPLY CIRCUIT FOR OPEN CIRCUIT</b> <ul style="list-style-type: none"> <li>• Turn the ignition switch to the ON position (Engine off).</li> <li>• Measure the voltage between fuel injector No.3 connector terminal B and body ground.</li> <li>• Is the voltage <b>B+</b> ?</li> </ul>	Yes	Go to the next step.
		No	Repair or replace suspected part, then go to Step 8.
6	<b>INSPECT FUEL INJECTOR NO.3 SIGNAL CIRCUIT FOR OPEN CIRCUIT</b> <ul style="list-style-type: none"> <li>• Inspect continuity between fuel injector No.3 terminal A (wiring harness-side) and PCM terminal 2BF (wiring harness-side).</li> <li>• Is there continuity?</li> </ul>	Yes	Go to the next step.
		No	Repair or replace suspected part, then go to Step 8.
7	<b>INSPECT FUEL INJECTOR NO.3</b>	Yes	Replace the fuel injector No.3, then go to the next step.

## 2007 Mazda CX-9 Grand Touring

2007 ENGINE PERFORMANCE On-Board Diagnostic (MZI-3.5) - CX-9

	<ul style="list-style-type: none"> <li>Inspect the fuel injector No.3.</li> </ul> <p>(see <b><u>FUEL INJECTOR INSPECTION [MZI-3.5]</u></b> .)</p> <ul style="list-style-type: none"> <li>Is there any malfunction?</li> </ul>	No	Go to the next step.
8	<p><b>VERIFY TROUBLESHOOTING OF DTC P0203 HAS BEEN COMPLETED</b></p> <ul style="list-style-type: none"> <li>Verify that all disconnected connectors reconnected.</li> <li>Clear DTC from memory using M-MDS.</li> <li>Start the engine.</li> <li>Perform the "KOEO/KOER self-test"</li> </ul> <p>(See <b><u>KOEO/KOER SELF TEST [MZI-3.5]</u></b>.)</p> <ul style="list-style-type: none"> <li>Is same DTC present?</li> </ul>	Yes	Replace the PCM, then go to the next step.
		No	Go to the next step.
9	<p><b>VERIFY AFTER REPAIR PROCEDURE</b></p> <ul style="list-style-type: none"> <li>Perform the "AFTER REPAIR PROCEDURE".</li> </ul> <p>(See <b><u>AFTER REPAIR PROCEDURE [MZI-3.5]</u></b>.)</p> <ul style="list-style-type: none"> <li>Are any DTCs present?</li> </ul>	Yes	Go to the applicable DTC inspection. (See <b><u>DTC TABLE [MZI-3.5]</u></b> .)
		No	Troubleshooting completed.

### DTC P0204 [MZI-3.5]

#### DTC P0204 (MZI-3.5) DETECTION CONDITION AND POSSIBLE CAUSES

DTC P0204	Injector circuit/open-cylinder No.4
<b>DETECTION CONDITION</b>	<ul style="list-style-type: none"> <li>The CCM monitors the operation of the fuel injector drivers in the PCM. The test if the fuel injector circuitry is inoperative.</li> </ul>
<b>POSSIBLE CAUSE</b>	<ul style="list-style-type: none"> <li>Fuel injector No.4 malfunction</li> <li>Connector or terminal malfunction</li> <li>Open circuit between fuel pump relay and fuel injector No.4 terminal B</li> <li>Open circuit between fuel injector No.4 terminal A and PCM terminal 2BH</li> </ul>

## 2007 Mazda CX-9 Grand Touring

2007 ENGINE PERFORMANCE On-Board Diagnostic (MZI-3.5) - CX-9

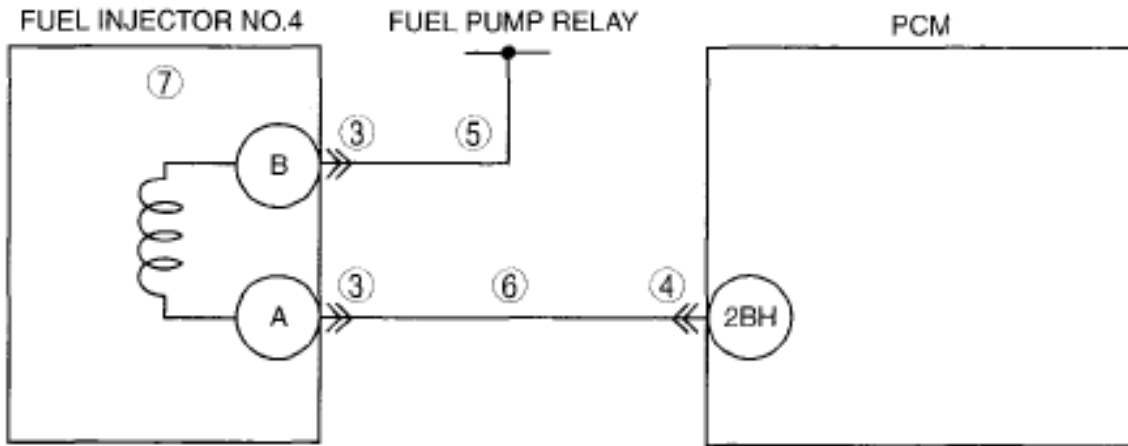

PCM  
WIRING HARNESS-SIDE CONNECTOR

FUEL INJECTOR NO.4  
WIRING HARNESS-SIDE CONNECTOR

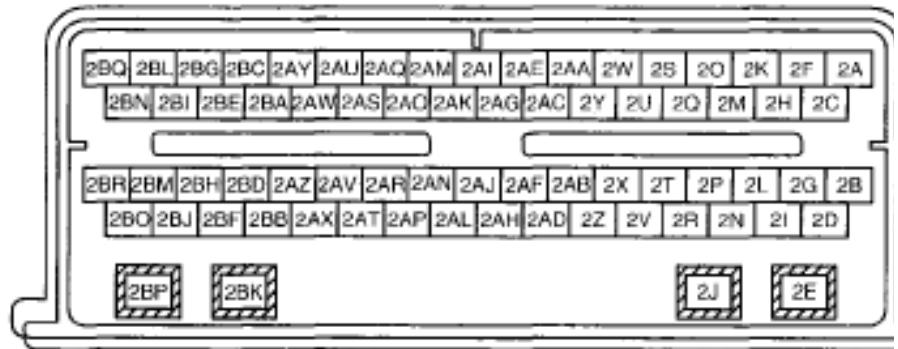

### DIAGNOSTIC PROCEDURE

#### DTC P0204 (MZI-3.5) DIAGNOSTIC PROCEDURE

STEP	INSPECTION		ACTION
1	<b>VERIFY FREEZE FRAME DATA HAS BEEN RECORDED</b>  • Has FREEZE FRAME DATA been recorded?	Yes	Go to the next step.
		No	Record FREEZE FRAME DATA on the repair order, then go to the next step.
2	<b>VERIFY RELATED REPAIR INFORMATION AVAILABILITY</b>  • Verify related Service Bulletins availability.	Yes	Perform repair or diagnosis according to available Service Bulletins.  • If vehicle is not repaired, go to the next step.

## 2007 Mazda CX-9 Grand Touring

2007 ENGINE PERFORMANCE On-Board Diagnostic (MZI-3.5) - CX-9

	<ul style="list-style-type: none"> <li>• Is any related Service Bulletins available?</li> </ul>	No	Go to the next step.
3	<b>INSPECT FUEL INJECTOR NO.4 CONNECTOR FOR POOR CONNECTION</b> <ul style="list-style-type: none"> <li>• Turn the ignition switch off.</li> <li>• Disconnect the fuel injector No.4 connector.</li> <li>• Inspect for poor connection (such as damaged/pulled-out pins, corrosion).</li> <li>• Are there malfunction?</li> </ul>	Yes	Repair or replace suspected part, then go to Step 8.
		No	Go to the next step.
4	<b>INSPECT PCM CONNECTOR FOR POOR CONNECTION</b> <ul style="list-style-type: none"> <li>• Turn the ignition switch off.</li> <li>• Disconnect the PCM connector.</li> <li>• Inspect for poor connection (such as damaged/pulled-out pins, corrosion).</li> <li>• Is there malfunction?</li> </ul>	Yes	Repair or replace suspected part, then go to Step 8.
		No	Go to the next step.
5	<b>INSPECT FUEL INJECTOR NO.4 POWER SUPPLY CIRCUIT FOR OPEN CIRCUIT</b> <ul style="list-style-type: none"> <li>• Turn the ignition switch to the ON position (Engine off).</li> <li>• Measure the voltage between fuel injector No.4 connector terminal B and body ground.</li> <li>• Is the voltage <b>B+</b> ?</li> </ul>	Yes	Go to the next step.
		No	Repair or replace suspected part, then go to Step 8.
6	<b>INSPECT FUEL INJECTOR NO.4 SIGNAL CIRCUIT FOR OPEN CIRCUIT</b> <ul style="list-style-type: none"> <li>• Inspect continuity between fuel injector No.4 terminal A (wiring harness-side) and PCM terminal 2BH (wiring harness-side).</li> <li>• Is there continuity?</li> </ul>	Yes	Go to the next step.
		No	Repair or replace suspected part, then go to Step 8.
7	<b>INSPECT FUEL INJECTOR NO.4</b>	Yes	Replace the fuel injector No.4, then go to the next step.

## 2007 Mazda CX-9 Grand Touring

2007 ENGINE PERFORMANCE On-Board Diagnostic (MZI-3.5) - CX-9

	<ul style="list-style-type: none"> <li>Inspect the fuel injector No.4.</li> </ul> <p>(see <b><u>FUEL INJECTOR INSPECTION [MZI-3.5]</u></b> .)</p> <ul style="list-style-type: none"> <li>Is there any malfunction?</li> </ul>	No	Go to the next step.
8	<p><b>VERIFY TROUBLESHOOTING OF DTC P0204 HAS BEEN COMPLETED</b></p> <ul style="list-style-type: none"> <li>Verify that all disconnected connectors reconnected.</li> <li>Clear DTC from memory using M-MDS.</li> <li>Start the engine.</li> <li>Perform the "KOEO/KOER self-test"</li> </ul> <p>(See <b><u>KOEO/KOER SELF TEST [MZI-3.5]</u></b>.)</p> <ul style="list-style-type: none"> <li>Is same DTC present?</li> </ul>	Yes	Replace the PCM, then go to the next step.
		No	Go to the next step.
9	<p><b>VERIFY AFTER REPAIR PROCEDURE</b></p> <ul style="list-style-type: none"> <li>Perform the "AFTER REPAIR PROCEDURE".</li> </ul> <p>(See <b><u>AFTER REPAIR PROCEDURE [MZI-3.5]</u></b>.)</p> <ul style="list-style-type: none"> <li>Are any DTCs present?</li> </ul>	Yes	Go to the applicable DTC inspection. (See <b><u>DTC TABLE [MZI-3.5]</u></b> .)
		No	Troubleshooting completed.

### DTC P0205 [MZI-3.5]

#### DTC P0205 (MZI-3.5) DETECTION CONDITION AND POSSIBLE CAUSES

<b>DTC P0205</b>	<b>Injector circuit/open-cylinder No.5</b>
<b>DETECTION CONDITION</b>	<ul style="list-style-type: none"> <li>The CCM monitors the operation of the fuel injector drivers in the PCM. The test if the fuel injector circuitry is inoperative.</li> </ul>
<b>POSSIBLE CAUSE</b>	<ul style="list-style-type: none"> <li>Fuel injector No.5 malfunction</li> <li>Connector or terminal malfunction</li> <li>Open circuit between fuel pump relay and fuel injector No.5 terminal B</li> <li>Open circuit between fuel injector No.5 terminal A and PCM terminal 2BB</li> </ul>

## 2007 Mazda CX-9 Grand Touring

2007 ENGINE PERFORMANCE On-Board Diagnostic (MZI-3.5) - CX-9

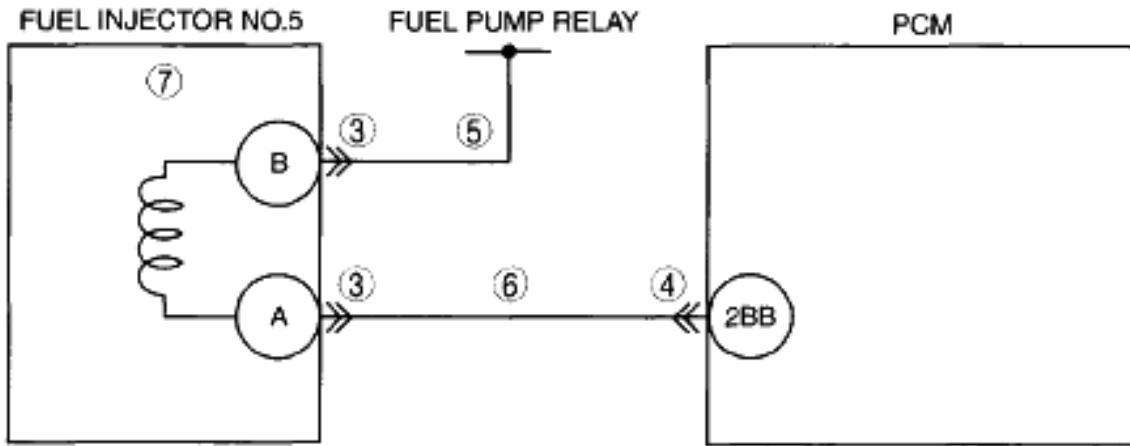

PCM  
WIRING HARNESS-SIDE CONNECTOR

FUEL INJECTOR NO.5  
WIRING HARNESS-SIDE CONNECTOR

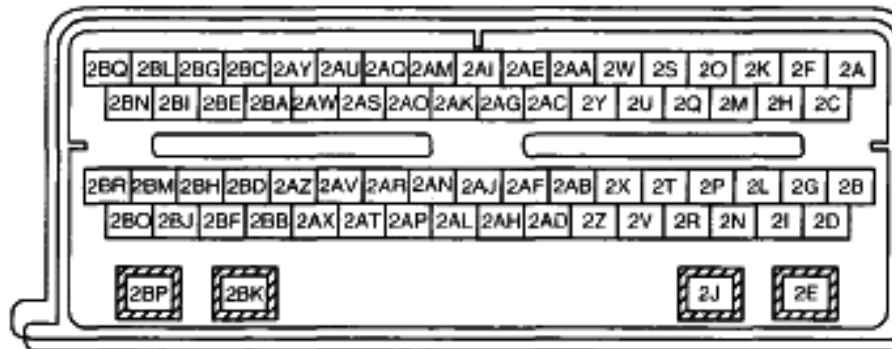

### DIAGNOSTIC PROCEDURE

#### DTC P0205 (MZI-3.5) DETECTION CONDITION AND POSSIBLE CAUSES

STEP	INSPECTION		ACTION
1	<b>VERIFY FREEZE FRAME DATA HAS BEEN RECORDED</b> <ul style="list-style-type: none"> <li>Has FREEZE FRAME DATA been recorded?</li> </ul>	Yes	Go to the next step.
		No	Record FREEZE FRAME DATA on the repair order, then go to the next step.
2	<b>VERIFY RELATED REPAIR INFORMATION AVAILABILITY</b> <ul style="list-style-type: none"> <li>Verify related Service Bulletins availability.</li> </ul>	Yes	Perform repair or diagnosis according to available Service Bulletins. <ul style="list-style-type: none"> <li>If vehicle is not repaired, go to the next step.</li> </ul>

## 2007 Mazda CX-9 Grand Touring

2007 ENGINE PERFORMANCE On-Board Diagnostic (MZI-3.5) - CX-9

	<ul style="list-style-type: none"> <li>• Is any related Service Bulletins available?</li> </ul>	No	Go to the next step.
3	<b>INSPECT FUEL INJECTOR NO.5 CONNECTOR FOR POOR CONNECTION</b> <ul style="list-style-type: none"> <li>• Turn the ignition switch off.</li> <li>• Disconnect the fuel injector No.5 connector.</li> <li>• Inspect for poor connection (such as damaged/pulled-out pins, corrosion).</li> <li>• Are there malfunction?</li> </ul>	Yes	Repair or replace suspected part, then go to Step 8.
		No	Go to the next step.
4	<b>INSPECT PCM CONNECTOR FOR POOR CONNECTION</b> <ul style="list-style-type: none"> <li>• Turn the ignition switch off.</li> <li>• Disconnect the PCM connector.</li> <li>• Inspect for poor connection (such as damaged/pulled-out pins, corrosion).</li> <li>• Is there malfunction?</li> </ul>	Yes	Repair or replace suspected part, then go to Step 8.
		No	Go to the next step.
5	<b>INSPECT FUEL INJECTOR NO.5 POWER SUPPLY CIRCUIT FOR OPEN CIRCUIT</b> <ul style="list-style-type: none"> <li>• Turn the ignition switch to the ON position (Engine off).</li> <li>• Measure the voltage between fuel injector No.5 connector terminal B and body ground.</li> <li>• Is the voltage <b>B+</b> ?</li> </ul>	Yes	Go to the next step.
		No	Repair or replace suspected part, then go to Step 8.
6	<b>INSPECT FUEL INJECTOR NO.5 SIGNAL CIRCUIT FOR OPEN CIRCUIT</b> <ul style="list-style-type: none"> <li>• Inspect continuity between fuel injector No.5 terminal A (wiring harness-side) and PCM terminal 2BB (wiring harness-side).</li> <li>• Is there continuity?</li> </ul>	Yes	Go to the next step.
		No	Repair or replace suspected part, then go to Step 8.
7	<b>INSPECT FUEL INJECTOR NO.5</b>	Yes	Replace the fuel injector No.5, then go to the next step.

## 2007 Mazda CX-9 Grand Touring

2007 ENGINE PERFORMANCE On-Board Diagnostic (MZI-3.5) - CX-9

	<ul style="list-style-type: none"> <li>Inspect the fuel injector No.5.</li> </ul> <p>(see <b><u>FUEL INJECTOR INSPECTION [MZI-3.5]</u></b> .)</p> <ul style="list-style-type: none"> <li>Is there any malfunction?</li> </ul>	No	Go to the next step.
8	<p><b>VERIFY TROUBLESHOOTING OF DTC P0205 HAS BEEN COMPLETED</b></p> <ul style="list-style-type: none"> <li>Verify that all disconnected connectors reconnected.</li> <li>Clear DTC from memory using M-MDS.</li> <li>Start the engine.</li> <li>Perform the "KOEO/KOER self-test"</li> </ul> <p>(See <b><u>KOEO/KOER SELF TEST [MZI-3.5]</u></b>.)</p> <ul style="list-style-type: none"> <li>Is same DTC present?</li> </ul>	Yes	Replace the PCM, then go to the next step.
		No	Go to the next step.
9	<p><b>VERIFY AFTER REPAIR PROCEDURE</b></p> <ul style="list-style-type: none"> <li>Perform the "AFTER REPAIR PROCEDURE".</li> </ul> <p>(See <b><u>AFTER REPAIR PROCEDURE [MZI-3.5]</u></b>.)</p> <ul style="list-style-type: none"> <li>Are any DTCs present?</li> </ul>	Yes	Go to the applicable DTC inspection. (See <b><u>DTC TABLE [MZI-3.5]</u></b> .)
		No	Troubleshooting completed.

### DTC P0206 [MZI-3.5]

#### DTC P0206 (MZI-3.5) DETECTION CONDITION AND POSSIBLE CAUSES

DTC P0206	Injector circuit/open-cylinder No.6
<b>DETECTION CONDITION</b>	<ul style="list-style-type: none"> <li>The CCM monitors the operation of the fuel injector drivers in the PCM. The test if the fuel injector circuitry is inoperative.</li> </ul>
<b>POSSIBLE CAUSE</b>	<ul style="list-style-type: none"> <li>Fuel injector No.6 malfunction</li> <li>Connector or terminal malfunction</li> <li>Open circuit between fuel pump relay and fuel injector No.6 terminal B</li> <li>Open circuit between fuel injector No.6 terminal A and PCM terminal 2BD</li> </ul>



# 2007 Mazda CX-9 Grand Touring

2007 ENGINE PERFORMANCE On-Board Diagnostic (MZI-3.5) - CX-9

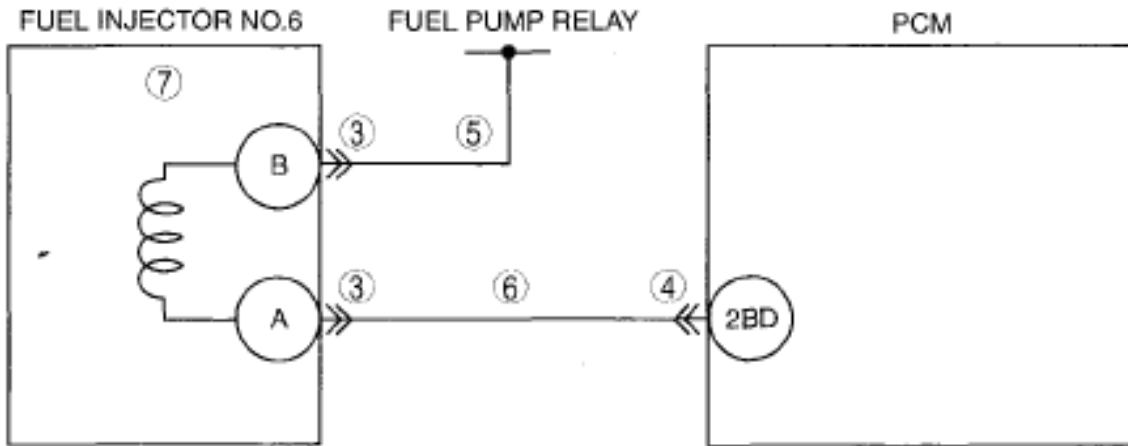

PCM  
WIRING HARNESS-SIDE CONNECTOR

FUEL INJECTOR NO.6  
WIRING HARNESS-SIDE CONNECTOR

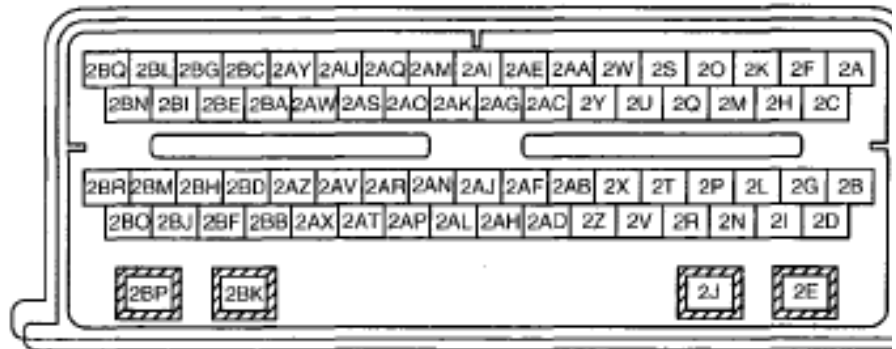

## DIAGNOSTIC PROCEDURE

### DTC P0206 (MZI-3.5) DIAGNOSTIC PROCEDURE

STEP	INSPECTION		ACTION
1	<b>VERIFY FREEZE FRAME DATA HAS BEEN RECORDED</b>  • Has FREEZE FRAME DATA been recorded?	Yes	Go to the next step.
		No	Record FREEZE FRAME DATA on the repair order, then go to the next step.
2	<b>VERIFY RELATED REPAIR INFORMATION AVAILABILITY</b>  • Verify related Service Bulletins availability.	Yes	Perform repair or diagnosis according to available Service Bulletins.  • If vehicle is not repaired, go to the next step.

## 2007 Mazda CX-9 Grand Touring

2007 ENGINE PERFORMANCE On-Board Diagnostic (MZI-3.5) - CX-9

	<ul style="list-style-type: none"> <li>Is any related Service Bulletins available?</li> </ul>	No	Go to the next step.
3	<b>INSPECT FUEL INJECTOR NO.6 CONNECTOR FOR POOR CONNECTION</b> <ul style="list-style-type: none"> <li>Turn the ignition switch off.</li> <li>Disconnect the fuel injector No.6 connector.</li> <li>Inspect for poor connection (such as damaged/pulled-out pins, corrosion).</li> <li>Are there malfunction?</li> </ul>	Yes	Repair or replace suspected part, then go to Step 8.
		No	Go to the next step.
4	<b>INSPECT PCM CONNECTOR FOR POOR CONNECTION</b> <ul style="list-style-type: none"> <li>Turn the ignition switch off.</li> <li>Disconnect the PCM connector.</li> <li>Inspect for poor connection (such as damaged/pulled-out pins, corrosion).</li> <li>Is there malfunction?</li> </ul>	Yes	Repair or replace suspected part, then go to Step 8.
		No	Go to the next step.
5	<b>INSPECT FUEL INJECTOR NO.6 POWER SUPPLY CIRCUIT FOR OPEN CIRCUIT</b> <ul style="list-style-type: none"> <li>Turn the ignition switch to the ON position (Engine off).</li> <li>Measure the voltage between fuel injector No.6 connector terminal B and body ground.</li> <li>Is the voltage <b>B+</b> ?</li> </ul>	Yes	Go to the next step.
		No	Repair or replace suspected part, then go to Step 8.
6	<b>INSPECT FUEL INJECTOR NO.6 SIGNAL CIRCUIT FOR OPEN CIRCUIT</b> <ul style="list-style-type: none"> <li>Inspect continuity between fuel injector No.6 terminal A (wiring harness-side) and PCM terminal 2BD (wiring harness-side).</li> <li>Is there continuity?</li> </ul>	Yes	Go to the next step.
		No	Repair or replace suspected part, then go to Step 8.
7	<b>INSPECT FUEL INJECTOR NO.6</b>	Yes	Replace the fuel injector No.6, then go to the next step.

## 2007 Mazda CX-9 Grand Touring

2007 ENGINE PERFORMANCE On-Board Diagnostic (MZI-3.5) - CX-9

	<ul style="list-style-type: none"> <li>Inspect the fuel injector No.6.</li> </ul> <p>(see <b><u>FUEL INJECTOR INSPECTION [MZI-3.5]</u></b> .)</p> <ul style="list-style-type: none"> <li>Is there any malfunction?</li> </ul>	No	Go to the next step.
8	<p><b>VERIFY TROUBLESHOOTING OF DTC P0206 HAS BEEN COMPLETED</b></p> <ul style="list-style-type: none"> <li>Verify that all disconnected connectors reconnected.</li> <li>Clear DTC from memory using M-MDS.</li> <li>Start the engine.</li> <li>Perform the "KOE0/KOER self-test"</li> </ul> <p>(See <b><u>KOE0/KOER SELF TEST [MZI-3.5]</u></b>.)</p> <ul style="list-style-type: none"> <li>Is same DTC present?</li> </ul>	Yes	Replace the PCM, then go to the next step.
		No	Go to the next step.
9	<p><b>VERIFY AFTER REPAIR PROCEDURE</b></p> <ul style="list-style-type: none"> <li>Perform the "AFTER REPAIR PROCEDURE".</li> </ul> <p>(See <b><u>AFTER REPAIR PROCEDURE [MZI-3.5]</u></b>.)</p> <ul style="list-style-type: none"> <li>Are any DTCs present?</li> </ul>	Yes	Go to the applicable DTC inspection. (See <b><u>DTC TABLE [MZI-3.5]</u></b> .)
		No	Troubleshooting completed.

### DTC P0222 [MZI-3.5]

#### DTC P0222 (MZI-3.5) DETECTION CONDITION AND POSSIBLE CAUSES

<b>DTC P0222</b>	<b>TP sensor No.2 circuit low input</b>
<b>DETECTION CONDITION</b>	<ul style="list-style-type: none"> <li>The TP sensor No.2 circuit was flagged as a concern by the PCM indicating a low voltage or open circuit.</li> </ul>
<b>POSSIBLE CAUSE</b>	<ul style="list-style-type: none"> <li>TP sensor No.2 malfunction</li> <li>Connector or terminal malfunction</li> <li>Open circuit between throttle body terminal C and PCM terminal 2AD</li> <li>Short to ground circuit between throttle body terminal C and PCM terminal 2AD</li> <li>Open circuit between throttle body terminal E and PCM terminal 2AH</li> </ul>

## 2007 Mazda CX-9 Grand Touring

2007 ENGINE PERFORMANCE On-Board Diagnostic (MZI-3.5) - CX-9

TP SENSOR NO.2 (THROTTLE BODY)

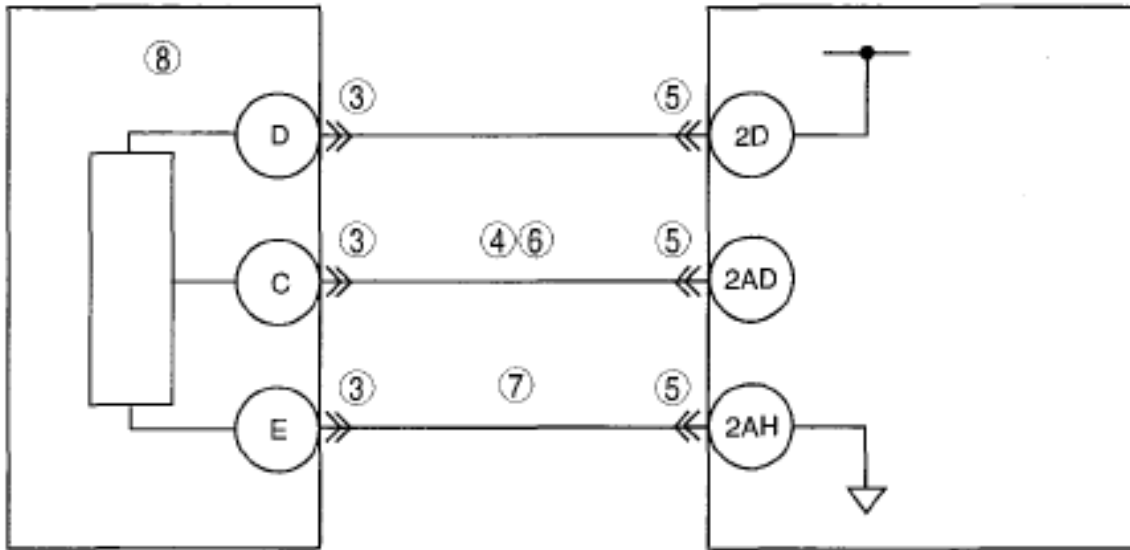

PCM  
WIRING HARNESS-SIDE CONNECTOR

THROTTLE BODY  
WIRING HARNESS-SIDE CONNECTOR

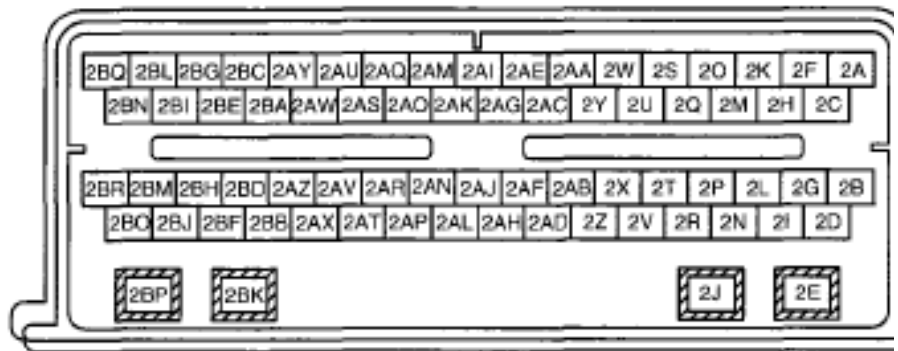
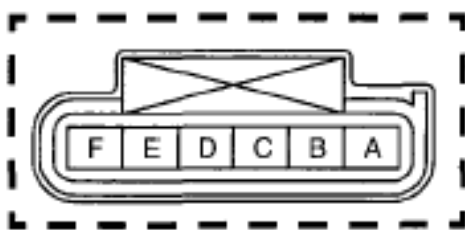

### DIAGNOSTIC PROCEDURE

#### DTC P0222 (MZI-3.5) DIAGNOSTIC PROCEDURE

STEP	INSPECTION		ACTION
1	<b>VERIFY FREEZE FRAME DATA HAS BEEN RECORDED</b>  • Has FREEZE FRAME DATA been recorded?	Yes	Go to the next step.
		No	Record FREEZE FRAME DATA on the repair order, then go to the next step.
2	<b>VERIFY RELATED REPAIR</b>	Yes	Perform repair or diagnosis according to

## 2007 Mazda CX-9 Grand Touring

2007 ENGINE PERFORMANCE On-Board Diagnostic (MZI-3.5) - CX-9

	<p><b>INFORMATION AVAILABILITY</b></p> <ul style="list-style-type: none"> <li>• Verify related Service Bulletins and/or on-line repair information availability.</li> <li>• Is any related Service Bulletins available?</li> </ul>		<p>the available Service Bulletins.</p> <ul style="list-style-type: none"> <li>• If the vehicle is not repaired, go to the next step.</li> </ul>
		No	Go to the next step.
3	<p><b>INSPECT TP SENSOR CONNECTOR FOR POOR CONNECTION</b></p> <ul style="list-style-type: none"> <li>• Turn the ignition switch off.</li> <li>• Disconnect the throttle body connector.</li> <li>• Inspect for poor connection (such as damaged/pulled-out pins, corrosion).</li> <li>• Are there any malfunction?</li> </ul>	Yes	Repair or replace suspected part, then go to Step 9.
		No	Go to the next step.
4	<p><b>INSPECT TP SENSOR CIRCUIT FOR SHORT TO GROUND</b></p> <ul style="list-style-type: none"> <li>• Turn the ignition switch to the ON position (Engine off).</li> <li>• Inspect for continuity between the following circuits: <ul style="list-style-type: none"> <li>○ TP sensor terminal D (wiring harness-side) and body ground</li> <li>○ TP sensor terminal C (wiring harness-side) and body ground</li> </ul> </li> <li>• Are there continuity?</li> </ul>	Yes	Repair or replace suspected part, then go to Step 9.
		No	Go to the next step.
5	<p><b>INSPECT PCM CONNECTOR FOR POOR CONNECTION</b></p> <ul style="list-style-type: none"> <li>• Turn the ignition switch off.</li> <li>• Disconnect the PCM connector.</li> <li>• Inspect for poor connection (such as damaged/pulled-out pins, corrosion).</li> <li>• Are there any malfunction?</li> </ul>	Yes	Repair or replace suspected part, then go to Step 9.
		No	Go to the next step.
6	<p><b>INSPECT TP SIGNAL CIRCUIT FOR OPEN CIRCUIT</b></p>	Yes	Go to the next step.

## 2007 Mazda CX-9 Grand Touring

2007 ENGINE PERFORMANCE On-Board Diagnostic (MZI-3.5) - CX-9

	<ul style="list-style-type: none"> <li>Inspect for continuity between throttle body connector terminal C (wiring harness-side) and PCM terminal 2AD (wiring harness-side).</li> <li>Is there continuity?</li> </ul>	No	Repair or replace suspected part, then go to Step 9.
7	<b>INSPECT TP GROUND CIRCUIT FOR OPEN CIRCUIT</b> <ul style="list-style-type: none"> <li>Turn the ignition switch off.</li> <li>Verify the continuity between TP sensor terminal E and body ground.</li> <li>Is the continuity?</li> </ul>	Yes	Go to the next step.
		No	Repair or replace suspected part, then go to Step 9.
8	<b>INSPECT TP SENSOR NO.2</b> <ul style="list-style-type: none"> <li>Inspect the TP sensor No.2.</li> </ul> <p>(see <b><u>THROTTLE POSITION (TP) SENSOR INSPECTION [MZI-3.5].</u></b>)</p> <ul style="list-style-type: none"> <li>Is there any malfunction?</li> </ul>	Yes	Replace the throttle body, then go to the next step.
		No	Go to the next step.
9	<b>VERIFY TROUBLESHOOTING OF DTC P0222 HAS BEEN COMPLETED</b> <ul style="list-style-type: none"> <li>Make sure to reconnect all disconnected connectors.</li> <li>Clear the DTC from the PCM memory using the M-MDS.</li> <li>Start the engine.</li> <li>Perform the "KOEO/KOER self-test".</li> </ul> <p>(See <b><u>KOEO/KOER SELF TEST [MZI-3.5].</u></b>)</p> <ul style="list-style-type: none"> <li>Is same DTC present?</li> </ul>	Yes	Replace the PCM, then go to the next step. (see <b><u>PCM REMOVAL/INSTALLATION [MZI-3.5].</u></b> )
		No	Go to the next step.
10	<b>VERIFY AFTER REPAIR PROCEDURE</b> <ul style="list-style-type: none"> <li>Perform the "AFTER REPAIR PROCEDURE".</li> </ul>	Yes	Go to the applicable DTC inspection. (See <b><u>DTC TABLE [MZI-3.5].</u></b> )

## 2007 Mazda CX-9 Grand Touring

2007 ENGINE PERFORMANCE On-Board Diagnostic (MZI-3.5) - CX-9

<p>(See <b><u>AFTER REPAIR PROCEDURE [MZI-3.5].</u></b>)</p> <ul style="list-style-type: none"><li>• Are any DTCs present?</li></ul>	No	Troubleshooting completed.
--	----	----------------------------

### DTC P0223 [MZI-3.5]

#### DTC P0223 (MZI-3.5) DETECTION CONDITION AND POSSIBLE CAUSES

<b>DTC P0223</b>	<b>TP sensor No.2 circuit high input</b>
<b>DETECTION CONDITION</b>	<ul style="list-style-type: none"><li>• The TP sensor No.2 circuit was flagged as a concern by the PCM indicating a high voltage.</li></ul>
<b>POSSIBLE CAUSE</b>	<ul style="list-style-type: none"><li>• TP sensor No.2 malfunction</li><li>• Connector or terminal malfunction</li><li>• Open circuit wiring harness between throttle body terminal C and PCM terminal 2</li><li>• TP sensor signal circuits are shorted each other</li></ul>

## 2007 Mazda CX-9 Grand Touring

2007 ENGINE PERFORMANCE On-Board Diagnostic (MZI-3.5) - CX-9

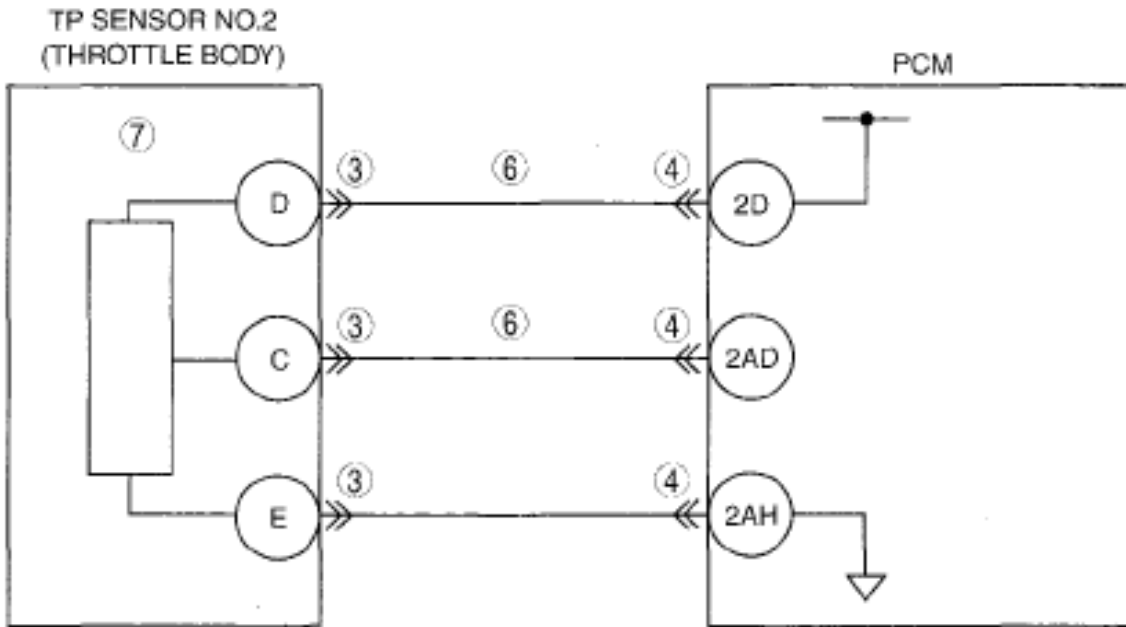

**THROTTLE BODY WIRING HARNESS-SIDE CONNECTOR**

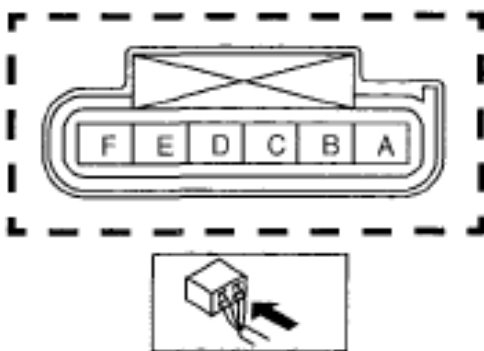

**PCM WIRING HARNESS-SIDE CONNECTOR**

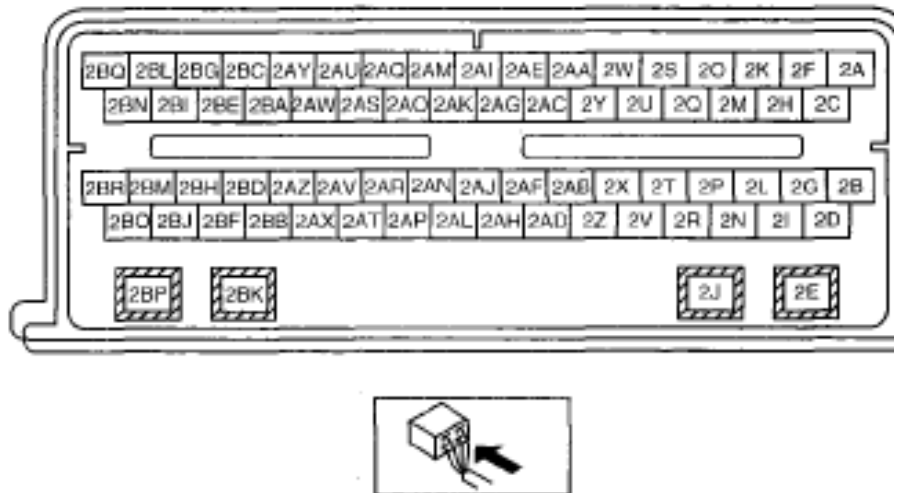

### DIAGNOSTIC PROCEDURE

#### DTC P0223 (MZI-3.5) DIAGNOSTIC PROCEDURE

STEP	INSPECTION		ACTION
1	<b>VERIFY FREEZE FRAME DATA HAS BEEN RECORDED</b>	Yes	Go to the next step.
		No	Record FREEZE FRAME DATA on the repair order, then go to the next step.
	<ul style="list-style-type: none"> <li>Has FREEZE FRAME DATA</li> </ul>		



## 2007 Mazda CX-9 Grand Touring

2007 ENGINE PERFORMANCE On-Board Diagnostic (MZI-3.5) - CX-9

	been recorded?		
2	<b>VERIFY RELATED REPAIR INFORMATION AVAILABILITY</b> <ul style="list-style-type: none"> <li>• Verify related Service Bulletins and/or on-line repair information availability.</li> <li>• Is any related Service Bulletins available?</li> </ul>	Yes	Perform repair or diagnosis according to the available Service Bulletins. <ul style="list-style-type: none"> <li>• If the vehicle is not repaired, go to the next step.</li> </ul>
		No	Go to the next step.
3	<b>INSPECT TP SENSOR CONNECTOR FOR POOR CONNECTION</b> <ul style="list-style-type: none"> <li>• Turn the ignition switch off.</li> <li>• Disconnect the throttle body connector.</li> <li>• Inspect for poor connection (such as damaged/pulled-out pins, corrosion).</li> <li>• Are there any malfunction?</li> </ul>	Yes	Repair or replace suspected part, then go to Step 8.
		No	Go to the next step.
4	<b>INSPECT PCM CONNECTOR FOR POOR CONNECTION</b> <ul style="list-style-type: none"> <li>• Turn the ignition switch off.</li> <li>• Disconnect the PCM connector.</li> <li>• Inspect for poor connection (such as damaged/pulled-out pins, corrosion).</li> <li>• Are there any malfunction?</li> </ul>	Yes	Repair or replace suspected part, then go to Step 8.
		No	Go to the next step.
5	<b>INSPECT TP SIGNAL CIRCUIT FOR OPEN CIRCUIT</b> <ul style="list-style-type: none"> <li>• Turn the ignition switch off.</li> <li>• Disconnect the PCM connector.</li> <li>• Disconnect the throttle body connector.</li> <li>• Inspect for continuity between the following terminals:                             <ul style="list-style-type: none"> <li>○ Throttle body terminal C and PCM terminal 2AD</li> <li>○ Throttle body terminal D and PCM terminal 2D</li> </ul> </li> <li>• Are there continuity?</li> </ul>	Yes	Go to the next step.
		No	Repair or replace suspected part, then go to Step 8.

## 2007 Mazda CX-9 Grand Touring

2007 ENGINE PERFORMANCE On-Board Diagnostic (MZI-3.5) - CX-9

6	<p><b>INSPECT TP SENSOR NO.2</b></p> <ul style="list-style-type: none"> <li>• Inspect the TP sensor No.2.</li> </ul> <p>(see <b><u>THROTTLE POSITION (TP) SENSOR INSPECTION [MZI-3.5].</u></b>)</p> <ul style="list-style-type: none"> <li>• Is there any malfunction?</li> </ul>	Yes	Replace the throttle body, then go to Step 8.
		No	Go to the next step.
7	<p><b>INSPECT TP SENSOR SIGNAL CIRCUITS FOR SHORT EACH OTHER</b></p> <ul style="list-style-type: none"> <li>• Disconnect the TP sensor and PCM connector.</li> <li>• Measure resistance between Throttle body connector terminal D and C.</li> <li>• Is the resistance more than 10 kilohms?</li> </ul>	Yes	Go to the next step.
		No	Repair or replace suspected part, then go to Step 8.
8	<p><b>VERIFY TROUBLESHOOTING OF DTC P0223 HAS BEEN COMPLETED</b></p> <ul style="list-style-type: none"> <li>• Make sure to reconnect all disconnected connectors.</li> <li>• Clear the DTC from the PCM memory using the M-MDS.</li> <li>• Start the engine.</li> <li>• Perform the "KOEO/KOER self-test".</li> </ul> <p>(See <b><u>KOEO/KOER SELF TEST [MZI-3.5].</u></b>)</p> <ul style="list-style-type: none"> <li>• Is same DTC present?</li> </ul>	Yes	Replace the PCM, then go to the next step. (see <b><u>PCM REMOVAL/INSTALLATION [MZI-3.5].</u></b> )
		No	Go to the next step.
9	<p><b>VERIFY AFTER REPAIR PROCEDURE</b></p> <ul style="list-style-type: none"> <li>• Perform the "AFTER REPAIR PROCEDURE".</li> </ul> <p>(See <b><u>AFTER REPAIR PROCEDURE [MZI-3.5].</u></b>)</p>	Yes	Go to the applicable DTC inspection. (See <b><u>DTC TABLE [MZI-3.5].</u></b> )
		No	Troubleshooting completed.

## 2007 Mazda CX-9 Grand Touring

2007 ENGINE PERFORMANCE On-Board Diagnostic (MZI-3.5) - CX-9

- Are any DTCs present?

### DTC P0230 [MZI-3.5]

#### DTC P0230 (MZI-3.5) DETECTION CONDITION AND POSSIBLE CAUSES

DTC P0230	FP primary circuit
<b>DETECTION CONDITION</b>	<ul style="list-style-type: none"><li>• The PCM monitors the fuel pump circuit output from the PCM. The test fails when fuel pump output is commanded ON (grounded) and excessive current draw is detected on the fuel pump circuit. The test also fails when the fuel pump output is commanded OFF and voltage is not detected on the fuel pump circuit. The PCM expects to detect vehicle power voltage coming through the fuel pump relay coil to the fuel pump circuit.</li></ul>
<b>POSSIBLE CAUSE</b>	<ul style="list-style-type: none"><li>• Fuel pump relay malfunction</li><li>• Connector or terminal malfunction</li><li>• Open circuit wiring harness between fuel pump relay terminal E and PCM terminal 1V</li><li>• Short to ground circuit between fuel pump relay terminal E and PCM terminal 1V</li><li>• Open circuit wiring harness between ignition switch and fuel pump relay terminal</li><li>• PCM malfunction</li></ul>

## 2007 Mazda CX-9 Grand Touring

2007 ENGINE PERFORMANCE On-Board Diagnostic (MZI-3.5) - CX-9

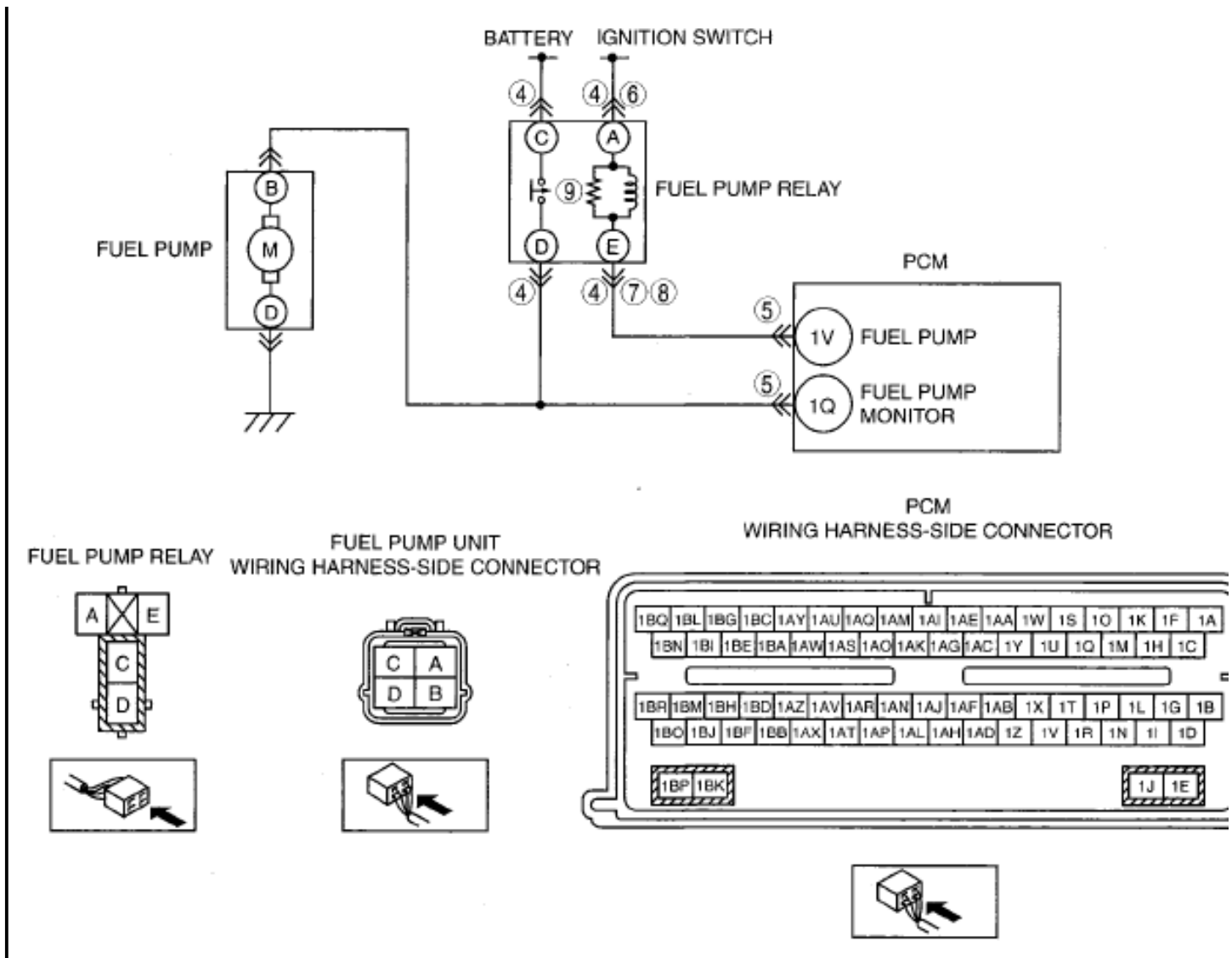

### DIAGNOSTIC PROCEDURE

#### DTC P0230 (MZI-3.5) DETECTION CONDITION AND POSSIBLE CAUSES

STEP	INSPECTION		ACTION
1	<b>VERIFY FREEZE FRAME DATA HAS BEEN RECORDED</b>	Yes	Go to the next step.
		No	Record FREEZE FRAME DATA on the repair order, then go to the next step.
2	<b>VERIFY RELATED REPAIR INFORMATION AVAILABILITY</b>	Yes	Perform repair or diagnosis according to available Service Bulletins.
	<ul style="list-style-type: none"> <li>Verify related Service Bulletins availability.</li> </ul>		<ul style="list-style-type: none"> <li>If vehicle is not repaired, go to the next step.</li> </ul>

## 2007 Mazda CX-9 Grand Touring

2007 ENGINE PERFORMANCE On-Board Diagnostic (MZI-3.5) - CX-9

	<ul style="list-style-type: none"> <li>• Is any related Service Bulletins available?</li> </ul>	No	Go to the next step.
3	<b>VERIFY RELATED PENDING CODE OR STORED DTC</b> <ul style="list-style-type: none"> <li>• Verify the related PENDING CODE or stored DTCs.</li> <li>• Are other DTCs present?</li> </ul>	Yes	Go to appropriate DTC inspection. (See <b>DTC TABLE [MZI-3.5]</b> .)
		No	Go to the next step.
4	<b>INSPECT FUEL PUMP RELAY CONNECTOR FOR POOR CONNECTION</b> <ul style="list-style-type: none"> <li>• Turn the ignition switch off.</li> <li>• Disconnect the fuel pump relay.</li> <li>• Inspect for poor connection (such as damaged/pulled-out pins, corrosion).</li> <li>• Are there malfunction?</li> </ul>	Yes	Repair or replace suspected part, then go to Step 10.
		No	Go to the next step.
5	<b>INSPECT PCM CONNECTOR FOR POOR CONNECTION</b> <ul style="list-style-type: none"> <li>• Turn the ignition switch off.</li> <li>• Disconnect PCM connector.</li> <li>• Inspect for poor connection (such as damaged/pulled-out pins, corrosion).</li> <li>• Are there malfunction?</li> </ul>	Yes	Repair or replace suspected part, then go to Step 10.
		No	Go to the next step.
6	<b>INSPECT FUEL PUMP RELAY POWER SUPPLY CIRCUIT FOR OPEN CIRCUIT</b> <ul style="list-style-type: none"> <li>• Turn the ignition switch to the ON position (Engine off).</li> <li>• Measure voltage between fuel pump relay connector terminal A (harness-side) and body ground.</li> <li>• Is voltage <b>B+</b> ?</li> </ul>	Yes	Go to the next step.
		No	Repair or replace suspected part, then go to Step 10.
7	<b>INSPECT FUEL PUMP CONTROL CIRCUIT FOR SHORT TO GROUND</b> <ul style="list-style-type: none"> <li>• Turn the ignition switch to the ON position (Engine off).</li> <li>• Inspect for continuity between fuel</li> </ul>	Yes	Repair or replace suspected part, then go to Step 10.

## 2007 Mazda CX-9 Grand Touring

2007 ENGINE PERFORMANCE On-Board Diagnostic (MZI-3.5) - CX-9

	<p>pump relay connector terminal E (harness-side) and body ground.</p> <ul style="list-style-type: none"> <li>• Is there continuity?</li> </ul>	No	Go to the next step.
8	<p><b>INSPECT FUEL PUMP CONTROL CIRCUIT FOR OPEN CIRCUIT</b></p> <ul style="list-style-type: none"> <li>• Turn the ignition switch off.</li> <li>• Inspect for continuity between fuel pump relay terminal E and PCM terminal 1V.</li> <li>• Is there continuity?</li> </ul>	Yes	Go to the next step.
		No	Repair or replace suspected part, then go to Step 10.
9	<p><b>INSPECT FUEL PUMP RELAY</b></p> <ul style="list-style-type: none"> <li>• Inspect the fuel pump relay.</li> </ul> <p>(see <b>RELAY INSPECTION</b> .)</p> <ul style="list-style-type: none"> <li>• Is there any malfunction?</li> </ul>	Yes	Replace the fuel pump relay, then go to the next step.
		No	Go to the next step.
10	<p><b>VERIFY TROUBLESHOOTING OF DTC P0230 HAS BEEN COMPLETED</b></p> <ul style="list-style-type: none"> <li>• Verify that all disconnected connectors reconnected.</li> <li>• Clear DTC from memory using M-MDS.</li> <li>• Start the engine.</li> <li>• Perform the "KOEO/KOER self-test"</li> </ul> <p>(See <b>KOEO/KOER SELF TEST [MZI-3.5]</b>.)</p> <ul style="list-style-type: none"> <li>• Is same DTC present?</li> </ul>	Yes	Replace the PCM, then go to the next step.
		No	Go to the next step.
11	<p><b>VERIFY AFTER REPAIR PROCEDURE</b></p> <ul style="list-style-type: none"> <li>• Perform the "AFTER REPAIR PROCEDURE".</li> </ul> <p>(See <b>AFTER REPAIR PROCEDURE [MZI-3.5]</b>.)</p> <ul style="list-style-type: none"> <li>• Are any DTCs present?</li> </ul>	Yes	Go to the applicable DTC inspection. (See <b>DTC TABLE [MZI-3.5]</b> .)
		No	Troubleshooting completed.

# 2007 Mazda CX-9 Grand Touring

2007 ENGINE PERFORMANCE On-Board Diagnostic (MZI-3.5) - CX-9

## DTC P0231 [MZI-3.5]

### DTC P0231 (MZI-3.5) DETECTION CONDITION AND POSSIBLE CAUSES

<b>DTC P0231</b>	<b>FP secondary circuit low</b>
<b>DETECTION CONDITION</b>	<ul style="list-style-type: none"> <li>The PCM monitors the fuel pump monitor circuit. The test fails if the PCM comm the fuel pump ON and B+ voltage is not detected on the FPM circuit.</li> </ul>
<b>POSSIBLE CAUSE</b>	<ul style="list-style-type: none"> <li>Fuel pump relay malfunction</li> <li>Connector or terminal malfunction</li> <li>Open circuit between battery and fuel pump relay terminal C</li> <li>Open circuit between fuel pump relay terminal D and PCM terminal 1Q</li> </ul>

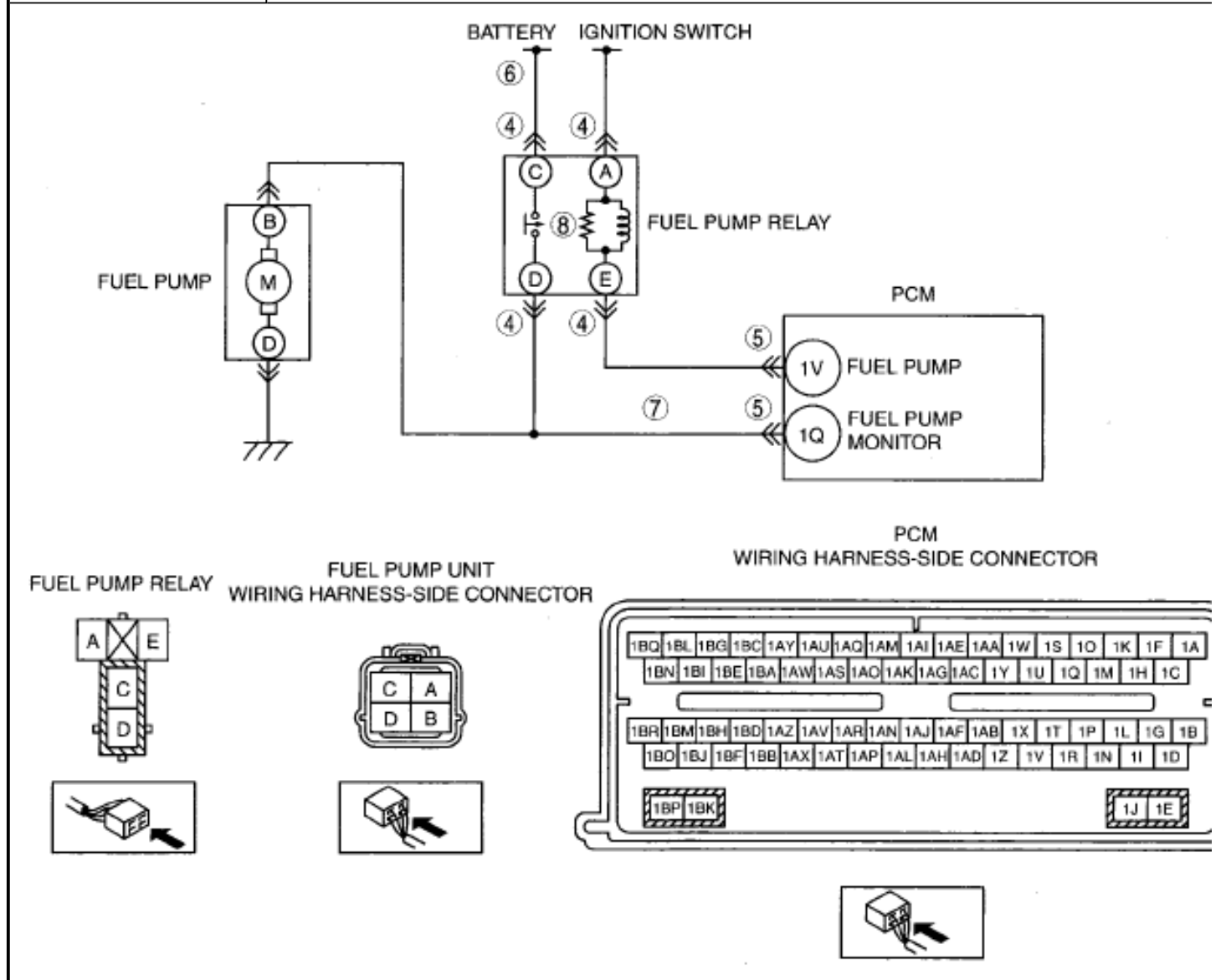

### DIAGNOSTIC PROCEDURE

## 2007 Mazda CX-9 Grand Touring

2007 ENGINE PERFORMANCE On-Board Diagnostic (MZI-3.5) - CX-9

### DTC P0231 (MZI-3.5) DETECTION CONDITION AND POSSIBLE CAUSES

STEP	INSPECTION		ACTION
1	<b>VERIFY FREEZE FRAME DATA HAS BEEN RECORDED</b> <ul style="list-style-type: none"> <li>• Has FREEZE FRAME DATA been recorded?</li> </ul>	Yes	Go to the next step.
		No	Record FREEZE FRAME DATA on the repair order, then go to the next step.
2	<b>VERIFY RELATED REPAIR INFORMATION AVAILABILITY</b> <ul style="list-style-type: none"> <li>• Verify related Service Bulletins availability.</li> <li>• Is any related Service Bulletins available?</li> </ul>	Yes	Perform repair or diagnosis according to available Service Bulletins. <ul style="list-style-type: none"> <li>• If vehicle is not repaired, go to the next step.</li> </ul>
		No	Go to the next step.
3	<b>VERIFY RELATED PENDING CODE OR STORED DTC</b> <ul style="list-style-type: none"> <li>• Verify the related PENDING CODE or stored DTCs.</li> <li>• Are other DTCs present?</li> </ul>	Yes	Go to appropriate DTC inspection. (See <b>DTC TABLE [MZI-3.5]</b> .)
		No	Go to the next step.
4	<b>INSPECT FUEL PUMP RELAY CONNECTOR FOR POOR CONNECTION</b> <ul style="list-style-type: none"> <li>• Turn the ignition switch off.</li> <li>• Disconnect the fuel pump relay.</li> <li>• Inspect for poor connection (such as damaged/pulled-out pins, corrosion).</li> <li>• Are there malfunction?</li> </ul>	Yes	Repair or replace suspected part, then go to Step 9.
		No	Go to the next step.
5	<b>INSPECT PCM CONNECTOR FOR POOR CONNECTION</b> <ul style="list-style-type: none"> <li>• Turn the ignition switch off.</li> <li>• Disconnect PCM connector.</li> <li>• Inspect for poor connection (such as damaged/pulled-out pins, corrosion).</li> <li>• Are there malfunction?</li> </ul>	Yes	Repair or replace suspected part, then go to Step 9.
		No	Go to the next step.
6	<b>INSPECT FUEL PUMP RELAY POWER SUPPLY CIRCUIT FOR OPEN CIRCUIT</b> <ul style="list-style-type: none"> <li>• Turn the ignition switch to the ON</li> </ul>	Yes	Go to the next step.
		No	Repair or replace suspected part, then go



## 2007 Mazda CX-9 Grand Touring

2007 ENGINE PERFORMANCE On-Board Diagnostic (MZI-3.5) - CX-9

	<p>position (Engine off).</p> <ul style="list-style-type: none"> <li>• Measure voltage between fuel pump relay connector terminal C (wiring harness-side) and body ground.</li> <li>• Is voltage <b>B+</b> ?</li> </ul>		to Step 9.
7	<p><b>INSPECT FUEL PUMP MONITOR CIRCUIT FOR OPEN CIRCUIT</b></p> <ul style="list-style-type: none"> <li>• Turn the ignition switch off.</li> <li>• Inspect continuity between fuel pump relay terminal D (wiring harness-side) and PCM terminal 1Q (wiring harness-side).</li> <li>• Is there continuity?</li> </ul>	Yes	Go to the next step.
		No	Repair or replace suspected part, then go to Step 9.
8	<p><b>INSPECT FUEL PUMP RELAY</b></p> <ul style="list-style-type: none"> <li>• Inspect the fuel pump relay.</li> </ul> <p>(see <b><u>RELAY INSPECTION</u></b> .)</p> <ul style="list-style-type: none"> <li>• Is there any malfunction?</li> </ul>	Yes	Replace the fuel pump relay, then go to the next step.
		No	Go to the next step.
9	<p><b>VERIFY TROUBLESHOOTING OF DTC P0231 HAS BEEN COMPLETED</b></p> <ul style="list-style-type: none"> <li>• Verify that all disconnected connectors reconnected.</li> <li>• Clear DTC from memory using M-MDS.</li> <li>• Start the engine.</li> <li>• Perform the "KOEO/KOER self-test"</li> </ul> <p>(See <b><u>KOEO/KOER SELF TEST [MZI-3.5]</u></b>.)</p> <ul style="list-style-type: none"> <li>• Is same DTC present?</li> </ul>	Yes	Replace the PCM, then go to the next step.
		No	Go to the next step.
10	<p><b>VERIFY AFTER REPAIR PROCEDURE</b></p> <ul style="list-style-type: none"> <li>• Perform the "AFTER REPAIR PROCEDURE".</li> </ul> <p>(See <b><u>AFTER REPAIR PROCEDURE [MZI-3.5]</u></b>.)</p>	Yes	Go to the applicable DTC inspection. (See <b><u>DTC TABLE [MZI-3.5]</u></b> .)
		No	Troubleshooting completed.

## 2007 Mazda CX-9 Grand Touring

2007 ENGINE PERFORMANCE On-Board Diagnostic (MZI-3.5) - CX-9

- Are any DTCs present?

### DTC P0232 [MZI-3.5]

#### DTC P0232 (MZI-3.5) DETECTION CONDITION AND POSSIBLE CAUSES

DTC P0232	FP secondary circuit high
<b>DETECTION CONDITION</b>	<ul style="list-style-type: none"><li>• The PCM monitors the fuel pump monitor circuit. This test fails when the PCM detects voltage on the fuel pump monitor circuit while the fuel pump is commanded OFF. The fuel pump monitor circuit is wired to a pull-up voltage inside the PCM. The fuel pump monitor circuit goes high if, with the key ON, engine OFF and the fuel pump commanded OFF, the fuel pump monitor/fuel pump power circuit loses its path to ground through the fuel pump. The fuel pump monitor circuit also goes high if the pump monitor/fuel pump power circuit is short to voltage.</li></ul>
<b>POSSIBLE CAUSE</b>	<ul style="list-style-type: none"><li>• Fuel pump relay malfunction</li><li>• Fuel pump malfunction</li><li>• Connector or terminal malfunction</li><li>• Open circuit between fuel pump terminal B and PCM terminal 1Q</li><li>• Fuel pump connector for poor connection</li><li>• Short to power supply between fuel pump terminal B and PCM terminal 1Q</li><li>• Short to power supply between fuel pump relay terminal D and PCM terminal 1Q</li></ul>

## 2007 Mazda CX-9 Grand Touring

2007 ENGINE PERFORMANCE On-Board Diagnostic (MZI-3.5) - CX-9

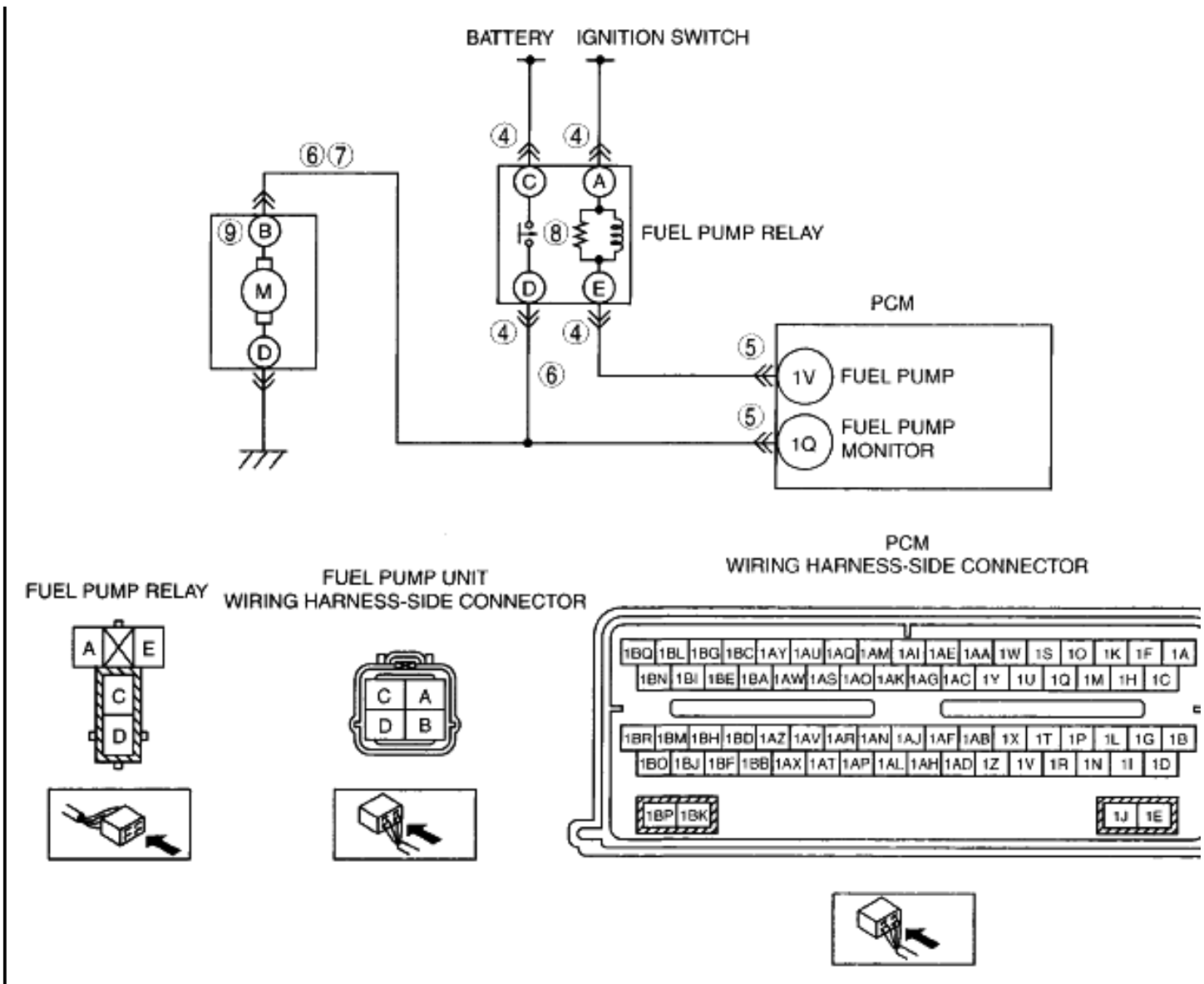

### DIAGNOSTIC PROCEDURE

#### DTC P0232 (MZI-3.5) DIAGNOSTIC PROCEDURE

STEP	INSPECTION		ACTION
1	<b>VERIFY FREEZE FRAME DATA HAS BEEN RECORDED</b>	Yes	Go to the next step.
		No	Record FREEZE FRAME DATA on the repair order, then go to the next step.
2	<b>VERIFY RELATED REPAIR INFORMATION AVAILABILITY</b>	Yes	Perform repair or diagnosis according to available Service Bulletins.
	• Verify related Service Bulletins		• If vehicle is not repaired, go to the

## 2007 Mazda CX-9 Grand Touring

2007 ENGINE PERFORMANCE On-Board Diagnostic (MZI-3.5) - CX-9

	availability.		next step.
	<ul style="list-style-type: none"> <li>Is any related Service Bulletins available?</li> </ul>	No	Go to the next step.
3	<p><b>VERIFY RELATED PENDING CODE OR STORED DTC</b></p> <ul style="list-style-type: none"> <li>Verify the related PENDING CODE or stored DTCs.</li> <li>Are other DTCs present?</li> </ul>	Yes	Go to appropriate DTC inspection. (See <b>DTC TABLE [MZI-3.5].</b> )
		No	Go to the next step.
4	<p><b>INSPECT FUEL PUMP RELAY CONNECTOR FOR POOR CONNECTION</b></p> <ul style="list-style-type: none"> <li>Turn the ignition switch off.</li> <li>Disconnect the fuel pump relay.</li> <li>Inspect for poor connection (such as damaged/pulled-out pins, corrosion).</li> <li>Are there malfunction?</li> </ul>	Yes	Repair or replace suspected part, then go to Step 10.
		No	Go to the next step.
5	<p><b>INSPECT PCM CONNECTOR FOR POOR CONNECTION</b></p> <ul style="list-style-type: none"> <li>Turn the ignition switch off.</li> <li>Disconnect PCM connector.</li> <li>Inspect for poor connection (such as damaged/pulled-out pins, corrosion).</li> <li>Are there malfunction?</li> </ul>	Yes	Repair or replace suspected part, then go to Step 10.
		No	Go to the next step.
6	<p><b>INSPECT FUEL PUMP MONITOR CIRCUIT FOR SHORT TO POWER SUPPLY</b></p> <ul style="list-style-type: none"> <li>Turn the ignition switch to the ON position (Engine off).</li> <li>Measure voltage between the following terminals:                             <ul style="list-style-type: none"> <li>Fuel pump relay terminal D (wiring harness-side) and body ground</li> <li>fuel pump terminal B (wiring harness-side) and body ground</li> </ul> </li> <li>Is voltage <b>B+</b> ?</li> </ul>	Yes	Repair or replace suspected part, then go to Step 10.
		No	Go to the next step.

## 2007 Mazda CX-9 Grand Touring

2007 ENGINE PERFORMANCE On-Board Diagnostic (MZI-3.5) - CX-9

7	<b>INSPECT FUEL PUMP MONITOR CIRCUIT FOR OPEN CIRCUIT</b> <ul style="list-style-type: none"> <li>• Turn the ignition switch off.</li> <li>• Inspect continuity between fuel pump terminal B (wiring harness-side) and PCM terminal 1Q (wiring harness-side).</li> <li>• Is there continuity?</li> </ul>	Yes	Go to the next step.
		No	Repair or replace suspected part, then go to Step 10.
8	<b>INSPECT FUEL PUMP RELAY</b> <ul style="list-style-type: none"> <li>• Inspect the fuel pump relay.</li> </ul> <p style="text-align: center;">(see <b><u>RELAY INSPECTION</u></b> .)</p> <ul style="list-style-type: none"> <li>• Is there any malfunction?</li> </ul>	Yes	Replace the fuel pump relay, then go to Step 10.
		No	Go to the next step.
9	<b>INSPECT FUEL PUMP</b> <ul style="list-style-type: none"> <li>• Inspect the fuel pump.</li> </ul> <p style="text-align: center;">(see <b><u>FUEL PUMP UNIT INSPECTION [MZI-3.5]</u></b> .)</p> <ul style="list-style-type: none"> <li>• Is there any malfunction?</li> </ul>	Yes	Replace the fuel pump unit, then go to the next step.
		No	Go to the next step.
10	<b>VERIFY TROUBLESHOOTING OF DTC P0232 HAS BEEN COMPLETED</b> <ul style="list-style-type: none"> <li>• Verify that all disconnected connectors reconnected.</li> <li>• Clear DTC from memory using M-MDS.</li> <li>• Start the engine.</li> <li>• Perform the "KOEO/KOER self-test"</li> </ul> <p style="text-align: center;">(See <b><u>KOEO/KOER SELF TEST [MZI-3.5]</u></b>.)</p> <ul style="list-style-type: none"> <li>• Is same DTC present?</li> </ul>	Yes	Replace the PCM, then go to the next step.
		No	Go to the next step.
11	<b>VERIFY AFTER REPAIR PROCEDURE</b> <ul style="list-style-type: none"> <li>• Perform the "AFTER REPAIR PROCEDURE".</li> </ul>	Yes	Go to the applicable DTC inspection. (See <b><u>DTC TABLE [MZI-3.5]</u></b> .)

## 2007 Mazda CX-9 Grand Touring

2007 ENGINE PERFORMANCE On-Board Diagnostic (MZI-3.5) - CX-9

(See <b><u>AFTER REPAIR PROCEDURE [MZI-3.5]</u></b> .)  • Are any DTCs present?	No	Troubleshooting completed.
---	----	----------------------------

### DTC P0297 [MZI-3.5]

#### DTC P0297 (MZI-3.5) DETECTION CONDITION AND POSSIBLE CAUSES

<b>DTC P0297</b>	<b>Vehicle over speed condition</b>
<b>DETECTION CONDITION</b>	<ul style="list-style-type: none"> <li>• P0297 indicates that the vehicle has been operated in a manner which caused the engine or vehicle to exceed a calibration limit.</li> </ul>
<b>POSSIBLE CAUSE</b>	<ul style="list-style-type: none"> <li>• Wheel slippage (water, ice, mud and snow).</li> <li>• Excessive engine rpm in neutral.</li> <li>• Vehicle drive at a high rate of speed.</li> </ul>

#### DIAGNOSTIC PROCEDURE

#### DTC P0297 (MZI-3.5) DIAGNOSTIC PROCEDURE

STEP	INSPECTION		ACTION
1	<b>VERIFY FREEZE FRAME DATA HAS BEEN RECORDED</b>  <ul style="list-style-type: none"> <li>• Has FREEZE FRAME DATA been recorded?</li> </ul>	Yes	Go to the next step.
		No	Record FREEZE FRAME DATA on the repair order, then go to the next step.
2	<b>VERIFY RELATED REPAIR INFORMATION AVAILABILITY</b>  <ul style="list-style-type: none"> <li>• Verify related Service Bulletins and/or on-line repair information availability.</li> <li>• Is any related Service Bulletins available?</li> </ul>	Yes	Perform repair or diagnosis according to the available Service Bulletins.  <ul style="list-style-type: none"> <li>• If the vehicle is not repaired, go to the next step.</li> </ul>
		No	Go to the next step.
3	<b>INSPECT VEHICLE OPERATION</b>  <ul style="list-style-type: none"> <li>• Check for:                             <ul style="list-style-type: none"> <li>○ Water, ice, mud and snow causing wheel slippage.</li> <li>○ Excessive engine speed in N (Neutral).</li> <li>○ Check whether the vehicle way driven at a high rate of speed.</li> </ul> </li> <li>• Was the vehicle driven under any</li> </ul>	Yes	Vehicle is normal. Then go to the next step.
		No	Clear DTCs and refer to " <b><u>DIAGNOSTIC INDEX</u></b> " if customer had any drive ability concerns. (see <b><u>QUICK DIAGNOSTIC CHART [MZI-3.5]</u></b> .)

## 2007 Mazda CX-9 Grand Touring

2007 ENGINE PERFORMANCE On-Board Diagnostic (MZI-3.5) - CX-9

	of the above conditions?		
4	<b>VERIFY TROUBLESHOOTING OF DTC P0297 HAS BEEN COMPLETED</b> <ul style="list-style-type: none"> <li>• Verify that all disconnected connectors are reconnected.</li> <li>• Turn the ignition switch to the ON position (Engine off).</li> <li>• Clear the DTC from the PCM memory using the M-MDS.</li> <li>• Start the engine and run it at idle.</li> <li>• Retrieve DTCs using the M-MDS.</li> <li>• Is the PENDING CODE for this DTC present?</li> </ul>	Yes	Replace PCM, then go to the next step. (see <b>PCM REMOVAL/INSTALLATION [MZI-3.5]</b> .)
		No	Go to the next step.
5	<b>VERIFY AFTER REPAIR PROCEDURE</b> <ul style="list-style-type: none"> <li>• Perform "AFTER REPAIR PROCEDURE".</li> </ul> <p style="text-align: center;">(See <b>AFTER REPAIR PROCEDURE [MZI-3.5]</b>.)</p> <ul style="list-style-type: none"> <li>• Are any DTC present?</li> </ul>	Yes	Go to the applicable DTC inspection. (See <b>DTC TABLE [MZI-3.5]</b> .)
		No	Troubleshooting completed.

### DTC P0300 [MZI-3.5]

#### DTC P0300 (MZI-3.5) DETECTION CONDITION AND POSSIBLE CAUSES

<b>DTC P0300</b>	<b>Random misfire detected</b>
<b>DETECTION CONDITION</b>	<ul style="list-style-type: none"> <li>• The PCM monitors the crankshaft position sensor input signal interval time. The PCM calculates the change of the interval time for each cylinder. If the change of interval time exceeds the pre-programmed criteria, the PCM detects a misfire in the corresponding cylinder. When the engine is running, the PCM counts the number of misfires that occurred at 200 crankshaft revolutions and 1,000 crankshaft revolutions and calculates the misfire ratio for each crankshaft revolution. If the ratio exceeds the pre-programmed criteria, the PCM determines that a misfire, which can damage the catalytic converter or affect emission performance, has occurred.</li> </ul>
	<ul style="list-style-type: none"> <li>• CMP sensor malfunction</li> <li>• CKP sensor malfunction</li> <li>• Ignition coil malfunction</li> <li>• Ignition system malfunction</li> </ul>

## 2007 Mazda CX-9 Grand Touring

2007 ENGINE PERFORMANCE On-Board Diagnostic (MZI-3.5) - CX-9

<b>POSSIBLE CAUSE</b>	<ul style="list-style-type: none"> <li>• MAF sensor contamination</li> <li>• Excess air suction in intake air system (between MAF/IAT sensor and dynamic chamber)</li> <li>• Vacuum hoses damages or improper connection</li> <li>• Fuel pump malfunction</li> <li>• Fuel pressure regulator malfunction</li> <li>• Fuel line clogged</li> <li>• Fuel filter clogged</li> <li>• Fuel runout</li> <li>• Poor quality fuel</li> <li>• Fuel leakage in fuel line</li> <li>• Insufficient compression</li> <li>• Variable valve timing control system improper operation</li> <li>• Purge solenoid valve malfunction</li> <li>• PCV valve malfunction</li> <li>• Related connector and terminal malfunction</li> <li>• Related wiring harness malfunction</li> </ul>
-----------------------	--

### DIAGNOSTIC PROCEDURE

#### DTC P0300 (MZI-3.5) DIAGNOSTIC PROCEDURE

STEP	INSPECTION		ACTION
1	<b>VERIFY FREEZE FRAME DATA HAS BEEN RECORDED</b> <ul style="list-style-type: none"> <li>• Has FREEZE FRAME DATA been recorded?</li> </ul>	Yes	Go to the next step.
		No	Record FREEZE FRAME DATA on the repair order, then go to the next step.
2	<b>VERIFY RELATED REPAIR INFORMATION AVAILABILITY</b> <ul style="list-style-type: none"> <li>• Verify related Service Bulletins and/or on-line repair information availability.</li> <li>• Is any related Service Bulletins available?</li> </ul>	Yes	Perform repair or diagnosis according to the available Service Bulletins. <ul style="list-style-type: none"> <li>• If the vehicle is not repaired, go to the next step.</li> </ul>
		No	Go to the next step.
3	<b>VERIFY RELATED PENDING CODE OR STORED DTCs</b> <ul style="list-style-type: none"> <li>• Turn the ignition switch off then to the ON position (Engine off).</li> <li>• Verify related pending code or</li> </ul>	Yes	Go to the appropriate DTC troubleshooting. (See <b><u>DTC TABLE [MZI-3.5]</u></b> .)
		No	Go to the next step.



## 2007 Mazda CX-9 Grand Touring

2007 ENGINE PERFORMANCE On-Board Diagnostic (MZI-3.5) - CX-9

	<p>stored DTCs.</p> <ul style="list-style-type: none"> <li>Are other DTCs present?</li> </ul>		
4	<p><b>VERIFY CURRENT INPUT SIGNAL STATUS (KEY TO ON/IDLE)</b></p> <ul style="list-style-type: none"> <li>Access APP1, APP2, APP3, ECT, IAT, MAF, RPM, TP_REL and VSS PIDs using the M-MDS.</li> </ul> <p>(see <b><u>PCM INSPECTION [MZI-3.5]</u></b> .)</p> <ul style="list-style-type: none"> <li>Is there any signal that is far out of specification when the ignition switch is in the ON position and engine runs at idle?</li> </ul>	Yes	<p>Inspect the suspected circuit or part or both according to inspection results. (see <b><u>PCM INSPECTION [MZI-3.5]</u></b> .) Then go to Step 18.</p>
		No	<p>Go to the next step.</p>
5	<p><b>VERIFY CURRENT INPUT SIGNAL STATUS UNDER TROUBLE CONDITION</b></p> <ul style="list-style-type: none"> <li>Inspect the same PIDs as in Step 4 when simulating the FREEZE FRAME DATA condition.</li> <li>Is there any signal which causes drastic changes?</li> </ul>	Yes	<p>Inspect the suspected circuit or part or both according to inspection results. (see <b><u>PCM INSPECTION [MZI-3.5]</u></b> .) Then go to Step 18.</p>
		No	<p>Go to the next step.</p>
6	<p><b>INSPECT CMP SENSOR</b></p> <ul style="list-style-type: none"> <li>Inspect the CMP sensor.</li> </ul> <p>(see <b><u>CAMSHAFT POSITION (CMP) SENSOR INSPECTION [MZI-3.5]</u></b> .)</p> <ul style="list-style-type: none"> <li>Is there any malfunction?</li> </ul>	Yes	<p>Inspect the installation condition for damage to the timing belt and gears, and repair malfunctioning parts.</p> <ul style="list-style-type: none"> <li>If it is normal, replace CMP sensor.</li> </ul> <p>(see <b><u>CAMSHAFT POSITION (CMP) SENSOR REMOVAL/INSTALLATION [MZI-3.5]</u></b> .)</p> <p>Then go to Step 18.</p>
		No	<p>Go to the next step.</p>
7	<p><b>VERIFY CKP SENSOR INSTALLATION CONDITION</b></p> <ul style="list-style-type: none"> <li>Inspect for CKP sensor looseness.</li> <li>Is the CKP sensor loose?</li> </ul>	Yes	<p>Retighten the CKP sensor, then go to Step 18. (see <b><u>CRANKSHAFT POSITION (CKP) SENSOR REMOVAL/INSTALLATION [MZI-3.5]</u></b> .)</p>

## 2007 Mazda CX-9 Grand Touring

2007 ENGINE PERFORMANCE On-Board Diagnostic (MZI-3.5) - CX-9

		No	Go to the next step.
8	<b>INSPECT IGNITION SYSTEM OPERATION</b> <ul style="list-style-type: none"> <li>• Perform the spark test.</li> </ul> <p>(see <b><u>ENGINE CONTROL SYSTEM OPERATION INSPECTION [MZI-3.5]</u></b> .)</p> <ul style="list-style-type: none"> <li>• Are the results of the spark test normal?</li> </ul>	Yes	Go to the next step.
		No	Repair or replace the malfunctioning part according to the spark test results, then go to Step 18.
9	<b>INSPECT MAF PID</b> <ul style="list-style-type: none"> <li>• Start the engine.</li> <li>• Access the MAF PID using the M-MDS.</li> <li>• Verify that the MAF PID changes quickly according to the engine speed when the engine is raced.</li> <li>• Is the MAF PID response normal?</li> </ul>	Yes	Go to the next step.
		No	Replace the MAF/IAT sensor, then go to Step 18. (see <b><u>INTAKE-AIR SYSTEM REMOVAL/INSTALLATION [MZI-3.5]</u></b> .)
10	<b>INSPECT FOR EXCESSIVE AIR SUCTION IN INTAKE AIR SYSTEM</b> <ul style="list-style-type: none"> <li>• Inspect for air leakage at the following:                             <ul style="list-style-type: none"> <li>○ Between the MAF/IAT sensor and the throttle body</li> <li>○ Between the throttle body and the dynamic chamber</li> </ul> </li> <li>• Is there any malfunction?</li> </ul>	Yes	Repair or replace the suspected part, then go to Step 18.
		No	Go to the next step.
11	<b>INSPECT FUEL LINE PRESSURE</b> <ul style="list-style-type: none"> <li>• Turn the ignition switch off.</li> <li>• Inspect the fuel line pressure.</li> </ul> <p>(see <b><u>FUEL LINE PRESSURE INSPECTION [MZI-3.5]</u></b> .)</p> <ul style="list-style-type: none"> <li>• Is there any malfunction?</li> </ul>	Yes	If the fuel line pressure is too low, go to the next step. If the fuel line pressure is excessively high, check as follows: <ul style="list-style-type: none"> <li>• Fuel pump maximum pressure</li> <li>• Fuel return line for clogging                             <ul style="list-style-type: none"> <li>○ If all of the above are normal, replace the pressure regulator.</li> </ul> </li> </ul> <p style="text-align: center;">(see <b><u>PRESSURE REGULATOR</u></b>)</p>

## 2007 Mazda CX-9 Grand Touring

2007 ENGINE PERFORMANCE On-Board Diagnostic (MZI-3.5) - CX-9

		<b><u>INSPECTION [MZI-3.5] .)</u></b>	
			Then go to Step 18.
		No	Go to Step 18.
12	<b>INSPECT FUEL LINE FROM FUEL PUMP TO FUEL DELIVERY PIPE</b> <ul style="list-style-type: none"> <li>• Visually inspect the fuel line for any leakage.</li> <li>• Is any fuel leakage found?</li> </ul>	Yes	Replace suspected fuel line, then go to Step 18.
		No	Inspect the low-pressure side fuel filter for the following: <ul style="list-style-type: none"> <li>• Foreign material or staining inside the fuel filter Perform the following actions as a result:</li> <li>• If foreign material or staining is found inside the fuel filter (low-pressure side), clean the fuel tank and filter.</li> <li>• If normal, replace the fuel pump unit.</li> </ul> <p style="text-align: center;">(see <b><u>FUEL PUMP UNIT REMOVAL/INSTALLATION [MZI-3.5] .)</u></b>)</p>
			Then, go to Step 18.
13	<b>INSPECT ENGINE COMPRESSION</b> <ul style="list-style-type: none"> <li>• Inspect the engine compression.</li> </ul> <p style="text-align: center;">(see <b><u>COMPRESSION INSPECTION [MZI-3.5] .)</u></b>)</p> <ul style="list-style-type: none"> <li>• Is it normal?</li> </ul>	Yes	Go to the next step.
		No	Perform an engine overhaul for repairs, then go to Step 18.
14	<b>INSPECT VARIABLE VALVE TIMING CONTROL SYSTEM OPERATION</b> <ul style="list-style-type: none"> <li>• Inspect the variable valve timing control system operation.</li> </ul> <p style="text-align: center;">(see <b><u>ENGINE CONTROL SYSTEM OPERATION INSPECTION [MZI-3.5] .)</u></b>)</p> <ul style="list-style-type: none"> <li>• Does the variable timing control</li> </ul>	Yes	Go to the next step.
		No	Repair or replace the malfunctioning part according to the variable valve timing control system inspection results, then go to Step 18.

## 2007 Mazda CX-9 Grand Touring

2007 ENGINE PERFORMANCE On-Board Diagnostic (MZI-3.5) - CX-9

	system work properly?		
15	<b>INSPECT OPERATION OF PURGE SOLENOID VALVE</b> <ul style="list-style-type: none"> <li>• Inspect the purge control system operation.</li> </ul> <p>(see <b><u>ENGINE CONTROL SYSTEM OPERATION INSPECTION [MZI-3.5]</u></b> .)</p> <ul style="list-style-type: none"> <li>• Does the purge control system work properly?</li> </ul>	Yes	Go to the next step.
		No	Repair or replace the malfunctioning part according to the purge control system inspection results, then go to Step 18.
16	<b>INSPECT PCV VALVE OPERATION</b> <ul style="list-style-type: none"> <li>• Turn the ignition switch off.</li> <li>• Remove the PCV valve and check the valve operation.</li> </ul> <p>(see <b><u>POSITIVE CRANKCASE VENTILATION (PCV) VALVE INSPECTION [MZI-3.5]</u></b> .)</p> <ul style="list-style-type: none"> <li>• Is the PCV valve operation normal?</li> </ul>	Yes	Replace the PCV valve, then go to Step 18.
		No	Go to the next step.
17	<b>INSPECT SEALING OF ENGINE COOLANT PASSAGE</b> <p><b>WARNING:</b></p> <ul style="list-style-type: none"> <li>• <b>Never remove the cooling system cap or loosen the radiator drain plug while the engine is running, or when the engine and radiator are hot. Scalding engine coolant and steam may shoot out and cause serious injury. It may also damage the engine and cooling system.</b></li> <li>• Turn off the engine and wait until it is cool. Even then, be very careful when removing the cap. Wrap a thick cloth around it and slowly turn it counterclockwise to the first</li> </ul>	Yes	Air penetrates due to poor sealing of the head gasket or other areas between the combustion chamber and the engine coolant passage. Repair or replace malfunctioning parts, then go to the next step.

## 2007 Mazda CX-9 Grand Touring

2007 ENGINE PERFORMANCE On-Board Diagnostic (MZI-3.5) - CX-9

	<p><b>stop. Step back while the pressure escapes</b></p> <ul style="list-style-type: none"> <li>• <b>When you are sure all the pressure is gone, press down on the cap using the cloth, turn it, and remove it.</b></li> <li>• Remove the radiator cap.</li> <li>• Implement the procedure to bleed air from the engine coolant, then run the engine at idle</li> <li>• Are there any small bubbles which make the engine coolant white at the filling opening?</li> </ul> <p><b>NOTE:</b></p> <ul style="list-style-type: none"> <li>• <b>Large bubbles are normal since they are remaining air coming from the engine coolant passage.</b></li> </ul>	No	Go to the next step.
18	<p><b>VERIFY TROUBLESHOOTING OF DTC P0300 HAS BEEN COMPLETED</b></p> <ul style="list-style-type: none"> <li>• Verify that all disconnected connectors are reconnected.</li> <li>• Clear the DTC from the PCM memory using the M-MDS.</li> <li>• Perform the KOER SELF TEST using the M-MDS.</li> </ul> <p>(See <b><u>KOEO/KOER SELF TEST [MZI-3.5].</u></b>)</p> <ul style="list-style-type: none"> <li>• Is the PENDING CODE for this DTC present?</li> </ul>	Yes	Replace the PCM, then go to the next step. (see <b><u>PCM REMOVAL/INSTALLATION [MZI-3.5] .</u></b> )
		No	Go to the next step.
19	<p><b>VERIFY AFTER REPAIR PROCEDURE</b></p> <ul style="list-style-type: none"> <li>• Perform the "AFTER REPAIR PROCEDURE".</li> </ul> <p>(See <b><u>AFTER REPAIR PROCEDURE [MZI-3.5].</u></b>)</p>	Yes	Go to the applicable DTC inspection. (See <b><u>DTC TABLE [MZI-3.5].</u></b> )
		No	Troubleshooting completed.

## 2007 Mazda CX-9 Grand Touring

2007 ENGINE PERFORMANCE On-Board Diagnostic (MZI-3.5) - CX-9

- |  |  |  |
|--|--|--|
|  | <ul style="list-style-type: none"> <li>• Are any DTC present?</li> </ul> |  |
|--|--|--|

### DTC P0301, P0302, P0303, P0304, P0305, P0306, P0316 [MZI-3.5]

#### DTC P0301, P0302, P0303, P0304, P0305, P0306, P0316 (MZI-3.5) DETECTION CONDITION AND POSSIBLE CAUSES

<b>DTC P0301</b>	<b>P0301: Cylinder No.1 misfire detected</b>
<b>DTC P0302</b>	<b>P0302: Cylinder No.2 misfire detected</b>
<b>DTC P0303</b>	<b>P0303: Cylinder No.3 misfire detected</b>
<b>DTC P0304</b>	<b>P0304: Cylinder No.4 misfire detected</b>
<b>DTC P0305</b>	<b>P0305: Cylinder No.5 misfire detected</b>
<b>DTC P0306</b>	<b>P0306: Cylinder No.6 misfire detected</b>
<b>DTC P0316</b>	<b>P0316: Misfire detected on startup (first 1000 revolutions)</b>
<b>DETECTION CONDITION</b>	<ul style="list-style-type: none"> <li>• The PCM monitors the crankshaft position sensor input signal interval time. The PCM calculates the change of the interval time for each cylinder. If the change of interval time exceeds the pre-programmed criteria, the PCM detects a misfire in the corresponding cylinder, when the engine is running, the PCM counts the number of misfires that occurred at 200 crankshaft revolutions and 1,000 crankshaft revolutions and calculates the misfire ratio for each crankshaft revolution. If the ratio exceeds the pre-programmed criteria, the PCM determines that a misfire, which can damage the catalytic converter or affect emission performance, has occurred.</li> </ul>
<b>POSSIBLE CAUSE</b>	<ul style="list-style-type: none"> <li>• Spark plug malfunction</li> <li>• Ignition system malfunction</li> <li>• Ignition coil malfunction</li> <li>• Fuel injector malfunction</li> <li>• Air suction in intake air system (between dynamic chamber and cylinder head)</li> <li>• Inadequate engine compression due to engine internal malfunction</li> <li>• Related connector or terminal malfunction</li> <li>• Related wiring harness malfunction</li> </ul>

#### DIAGNOSTIC PROCEDURE

#### DTC P0301, P0302, P0303, P0304, P0305, P0306, P0316 (MZI-3.5) DIAGNOSTIC PROCEDURE

STEP	INSPECTION		ACTION
1	<b>VERIFY FREEZE FRAME DATA HAS BEEN RECORDED</b> <ul style="list-style-type: none"> <li>• Has FREEZE FRAME DATA been recorded?</li> </ul>	Yes	Go to the next step.
		No	Record FREEZE FRAME DATA on the repair order, then go to the next step.
2	<b>VERIFY RELATED REPAIR</b>	Yes	Perform repair or diagnosis according to

## 2007 Mazda CX-9 Grand Touring

2007 ENGINE PERFORMANCE On-Board Diagnostic (MZI-3.5) - CX-9

	<p><b>INFORMATION AVAILABILITY</b></p> <ul style="list-style-type: none"> <li>• Verify related Service Bulletins and/or on-line repair information availability.</li> <li>• Is any related Service Bulletins available?</li> </ul>		<p>the available Service Bulletins.</p> <ul style="list-style-type: none"> <li>• If the vehicle is not repaired, go to the next step.</li> </ul>
		No	Go to the next step.
3	<p><b>VERIFY RELATED PENDING CODE OR STORED DTCs</b></p> <ul style="list-style-type: none"> <li>• Turn the ignition switch off then to the ON position (Engine off).</li> <li>• Verify related pending code or stored DTCs.</li> <li>• Are other DTCs present?</li> </ul>	Yes	Go to the appropriate DTC troubleshooting. (See <b><u>DTC TABLE [MZI-3.5]</u></b> .)
		No	Go to the next step.
4	<p><b>VERIFY CURRENT INPUT SIGNAL STATUS (KEY TO ON/IDLE)</b></p> <ul style="list-style-type: none"> <li>• Access APP1, APP2, APP3, ECT, IAT, MAF, RPM TP_REL and VSS PIDs using the M-MDS.</li> </ul> <p>(see <b><u>PCM INSPECTION [MZI-3.5]</u></b> .)</p> <ul style="list-style-type: none"> <li>• Is there any signal that is far out of specification when the ignition switch is in the ON position and the engine runs at idle?</li> </ul>	Yes	Inspect the suspected circuit or part or both according to inspection results. Then go to Step 13. (see <b><u>PCM INSPECTION [MZI-3.5]</u></b> .)
		No	Go to the next step.
5	<p><b>VERIFY CURRENT INPUT SIGNAL STATUS UNDER TROUBLE CONDITION</b></p> <ul style="list-style-type: none"> <li>• Inspect the same PIDs as in Step 4 when simulating the FREEZE FRAME DATA condition.</li> <li>• Is there any signal which causes drastic changes?</li> </ul>	Yes	Inspect the suspected circuit or part or both according inspection results. Then go to Step 13. (see <b><u>PCM INSPECTION [MZI-3.5]</u></b> .)
		No	Go to the next step.
6	<p><b>INSPECT SPARK PLUG CONDITION</b></p> <ul style="list-style-type: none"> <li>• Turn the ignition switch off.</li> <li>• Remove the spark plug from the suspected cylinder.</li> <li>• Check the sparkplug condition:</li> </ul>	Yes	<ul style="list-style-type: none"> <li>• If the spark plug is wet, fuel flooding is suspected. Go to Step 9.</li> <li>• If the spark plug has a crack, excess wear or improper gap, replace the malfunctioning spark plug. Then go to Step 13.</li> </ul>

## 2007 Mazda CX-9 Grand Touring

2007 ENGINE PERFORMANCE On-Board Diagnostic (MZI-3.5) - CX-9

	<ul style="list-style-type: none"> <li>○ Cracks</li> <li>○ Excess wear</li> <li>○ Gap</li> <li>○ Wet</li> </ul> <ul style="list-style-type: none"> <li>● Is any problem found on the spark plug?</li> </ul>		(see <b><u>SPARK PLUG REMOVAL/INSTALLATION [MZI-3.5]</u></b> .)
		No	Go to the next step.
7	<p><b>INSPECT IGNITION SYSTEM OPERATION FOR SUSPECTED CYLINDER</b></p> <ul style="list-style-type: none"> <li>● Perform the spark test for the suspected cylinder.</li> </ul> <p>(see <b><u>ENGINE CONTROL SYSTEM OPERATION INSPECTION [MZI-3.5]</u></b> .)</p> <ul style="list-style-type: none"> <li>● Are the results of the spark test normal?</li> </ul>	Yes	Go to the next step.
		No	Replace or replace the malfunctioning part according to the spark test results, then go to Step 13.
8	<p><b>INSPECT FUEL INJECTOR WIRING HARNESS</b></p> <ul style="list-style-type: none"> <li>● Remove the intake air system parts.</li> <li>● Disconnect the fuel injector connector on the suspected cylinder.</li> <li>● Connect the noid light to the fuel injector connector terminals.</li> <li>● Verify the light dimness during cranking.</li> <li>● Does the noid light illuminate?</li> </ul>	Yes	Go to the next step.
		No	Inspect the fuel injector wiring harnesses. Repair or replace if necessary, then go to Step 13.
9	<p><b>INSPECT FUEL INJECTOR OPERATION</b></p> <ul style="list-style-type: none"> <li>● Remove fuel injector from the suspected cylinder.</li> </ul> <p>(see <b><u>FUEL INJECTOR REMOVAL/INSTALLATION [MZI-3.5]</u></b> .)</p> <ul style="list-style-type: none"> <li>● Swap the fuel injector with one from another cylinder.</li> <li>● Start the engine and run it at idle.</li> </ul>	Yes	Replace fuel injector, then go to Step 13. (see <b><u>FUEL INJECTOR REMOVAL/INSTALLATION [MZI-3.5]</u></b> .)
		No	Go to the next step.



## 2007 Mazda CX-9 Grand Touring

2007 ENGINE PERFORMANCE On-Board Diagnostic (MZI-3.5) - CX-9

	<ul style="list-style-type: none"> <li>• Is there the misfire DTC for the cylinder which has a suspected fuel injector?</li> </ul>		
10	<p><b>INSPECT FOR AIR SUCTION AT INTAKE AIR SYSTEM</b></p> <ul style="list-style-type: none"> <li>• Inspect for air leakage at the following:                             <ul style="list-style-type: none"> <li>○ Around the connection of the dynamic chamber and the intake manifold</li> <li>○ Around the connection of the intake manifold and the cylinder head</li> </ul> </li> <li>• Is air leakage found?</li> </ul>	Yes	Repair or replace the suspected part, then go to Step 13.
		No	Go to the next step.
11	<p><b>INSPECT SEALING OF ENGINE COOLANT PASSAGE</b></p> <p><b>WARNING:</b></p> <ul style="list-style-type: none"> <li>• <b>Never remove the cooling system cap or loosen the radiator drain plug while the engine is running, or when the engine and radiator are hot. Scalding engine coolant and steam may shoot out and cause serious injury. It may also damage the engine and cooling system.</b></li> <li>• <b>Turn off the engine and wait until it is cool. Even then, be very careful when removing the cap. Wrap a thick cloth around it and slowly turn it counterclockwise to the first stop. Step back while the pressure escapes.</b></li> <li>• <b>When you are sure all the pressure is gone, press down on the cap using the cloth, turn it, and remove it.</b></li> <li>• Remove the radiator cap.</li> <li>• Implement the procedure to bleed air from the engine coolant, then run the engine at idle.</li> <li>• Are there any small bubbles which make the engine coolant white at</li> </ul>	Yes	Air penetrates due to poor sealing of the head gasket or other areas between the combustion chamber and the engine coolant passage. Repair or replace malfunctioning parts, then go to Step 13.

## 2007 Mazda CX-9 Grand Touring

2007 ENGINE PERFORMANCE On-Board Diagnostic (MZI-3.5) - CX-9

	<p>filling opening?</p> <p><b>NOTE:</b></p> <ul style="list-style-type: none"> <li>• <b>Large bubbles are normal since they are remaining air coming from the engine coolant passage.</b></li> </ul>	No	Go to the next step.
12	<p><b>INSPECT ENGINE COMPRESSION</b></p> <ul style="list-style-type: none"> <li>• Inspect the engine compression.</li> </ul> <p>(see <b>COMPRESSION INSPECTION [MZI-3.5]</b> .)</p> <ul style="list-style-type: none"> <li>• Is the engine compression normal?</li> </ul>	Yes	Go to the next step.
		No	Overhaul the engine, then go to the next step.
13	<p><b>VERIFY TROUBLESHOOTING OF MISFIRE DTC HAS BEEN COMPLETED</b></p> <ul style="list-style-type: none"> <li>• Verify that all disconnected connectors are reconnected.</li> <li>• Turn the ignition switch to the ON position (Engine off).</li> <li>• Clear the DTC from the PCM memory using the M-MDS.</li> <li>• Start the engine and run it at idle.</li> <li>• Retrieve DTCs using the M-MDS.</li> <li>• Is the PENDING CODE for this DTC present?</li> </ul>	Yes	Replace the PCM, then go to the next step. (see <b>PCM REMOVAL/INSTALLATION [MZI-3.5]</b> .)
		No	Go to the next step.
14	<p><b>VERIFY AFTER REPAIR PROCEDURE</b></p> <ul style="list-style-type: none"> <li>• Perform the "AFTER REPAIR PROCEDURE".</li> </ul> <p>(See <b>AFTER REPAIR PROCEDURE [MZI-3.5]</b>.)</p> <ul style="list-style-type: none"> <li>• Are any DTC present?</li> </ul>	Yes	Go to the applicable DTC inspection. (See <b>DTC TABLE [MZI-3.5]</b> .)
		No	Troubleshooting completed.

### DTC P0315 [MZI-3.5]

#### DTC P0315 (MZI-3.5) DETECTION CONDITION AND POSSIBLE CAUSES

DTC P0315	CKP system variation not learned
-----------	----------------------------------

## 2007 Mazda CX-9 Grand Touring

2007 ENGINE PERFORMANCE On-Board Diagnostic (MZI-3.5) - CX-9

<b>DETECTION CONDITION</b>	<ul style="list-style-type: none"> <li>The PCM is unable to learn and correct for mechanical inaccuracies in the crankshaft pulse wheel tooth spacing. This DTC disables the misfire monitor.</li> </ul>
<b>POSSIBLE CAUSE</b>	<ul style="list-style-type: none"> <li>Crankshaft pulse wheel teeth malfunction</li> <li>CKP sensor malfunction</li> </ul>

### DIAGNOSTIC PROCEDURE

#### DTC P0315 (MZI-3.5) DIAGNOSTIC PROCEDURE

STEP	INSPECTION		ACTION
1	<b>VERIFY FREEZE FRAME DATA HAS BEEN RECORDED</b> <ul style="list-style-type: none"> <li>Has FREEZE FRAME DATA been recorded?</li> </ul>	Yes	Go to the next step.
		No	Record FREEZE FRAME DATA on the repair order, then go to the next step.
2	<b>VERIFY RELATED REPAIR INFORMATION AVAILABILITY</b> <ul style="list-style-type: none"> <li>Verify related Service Bulletins and/or on-line repair information availability.</li> <li>Is any related Service Bulletins available?</li> </ul>	Yes	Perform repair or diagnosis according to the available Service Bulletins. <ul style="list-style-type: none"> <li>If the vehicle is not repaired, go to the next step.</li> </ul>
		No	Go to the next step.
3	<b>VERIFY RELATED PENDING CODE OR STORED DTCs</b> <ul style="list-style-type: none"> <li>Turn the ignition switch off then to the ON position (Engine off).</li> <li>Verify related pending code or stored DTCs.</li> <li>Are other DTCs present?</li> </ul>	Yes	Go to the appropriate DTC troubleshooting. (See <b><u>DTC TABLE [MZI-3.5]</u></b> .)
		No	Go to the next step.
4	<b>INSPECT PHYSICAL CONDITION OF CRANKSHAFT PULSE WHEEL</b> <p><b>NOTE:</b></p> <ul style="list-style-type: none"> <li>DTC P0315 is set when the PCM is unable to learn and correct for the mechanical variations in the crankshaft pulse wheel tooth spacing (the allowable correction tolerances are exceeded).</li> </ul>	Yes	Go to the next step.
		No	Repair if necessary. Then go to Step 6.
	<ul style="list-style-type: none"> <li>Inspect the crankshaft pulse wheel</li> </ul>		

## 2007 Mazda CX-9 Grand Touring

2007 ENGINE PERFORMANCE On-Board Diagnostic (MZI-3.5) - CX-9

	<p>for damaged teeth.</p> <ul style="list-style-type: none"> <li>Inspect the crankshaft pulse wheel for wobble.</li> <li>Check for a loose crankshaft pulse wheel.</li> <li>Check the CKP sensor for damage.</li> <li>Are the CKP sensor and crankshaft pulse wheel normal?</li> </ul>		
5	<p><b>INSPECT DAMPER AND PULLEY ASSEMBLY</b></p> <p><b>NOTE:</b></p> <ul style="list-style-type: none"> <li><b>This step is for engines that have damper mounted pulse rings. Remove the front cover if necessary to observe the crank pulley.</b></li> <li>Observe the crank pulley for wobble.</li> <li>Examine the EI pulse ring fastened to the harmonic dampener.</li> <li>Does the crank pulley wobble or is the pulse ring loose or damaged?</li> </ul>	Yes	Disconnect the negative battery terminal for 5 min to allow the PCM to learn the new profile. Install a new pulley or damper assembly. Then go to the next step.
		No	Go to the next step.
6	<p><b>VERIFY TROUBLESHOOTING OF DTC P0315 HAS BEEN COMPLETED</b></p> <ul style="list-style-type: none"> <li>Verify that all disconnected connectors are reconnected.</li> <li>Turn the ignition switch to the ON position (Engine off).</li> <li>Clear the DTC from the PCM memory using the M-MDS.</li> <li>Start the engine and run it at idle.</li> <li>Retrieve DTCs using the M-MDS.</li> <li>Is the PENDING CODE for this DTC present?</li> </ul>	Yes	Replace the PCM, then go to the next step. (see <b><u>PCM REMOVAL/INSTALLATION [MZI-3.5]</u></b> .)
		No	Go to the next step.
7	<p><b>VERIFY AFTER REPAIR PROCEDURE</b></p> <ul style="list-style-type: none"> <li>Perform the "AFTER REPAIR</li> </ul>	Yes	Go to the applicable DTC inspection. (See <b><u>DTC TABLE [MZI-3.5]</u></b> .)

## 2007 Mazda CX-9 Grand Touring

2007 ENGINE PERFORMANCE On-Board Diagnostic (MZI-3.5) - CX-9

	PROCEDURE".  (See <b><u>AFTER REPAIR PROCEDURE [MZI-3.5].</u></b> )  • Are any DTC present?	No	Troubleshooting completed.
--	---	----	----------------------------

### DTC P0320 [MZI-3.5]

#### DTC P0320 (MZI-3.5) DETECTION CONDITION AND POSSIBLE CAUSES

<b>DTC P0320</b>	<b>Ignition/distributor engine speed input circuit</b>
<b>DETECTION CONDITION</b>	<ul style="list-style-type: none"><li>• The ignition engine speed sensor input signal to the PCM is continuously monitor</li><li>• The test fails when the signal indicates that 2 successive erratic PIP pulses occur</li></ul>
<b>POSSIBLE CAUSE</b>	<ul style="list-style-type: none"><li>• Loose wires/connectors.</li><li>• Arcing secondary ignition components (coil, wires or plugs).</li><li>• On-board transmitter (2-way radio).</li></ul>

## 2007 Mazda CX-9 Grand Touring

2007 ENGINE PERFORMANCE On-Board Diagnostic (MZI-3.5) - CX-9

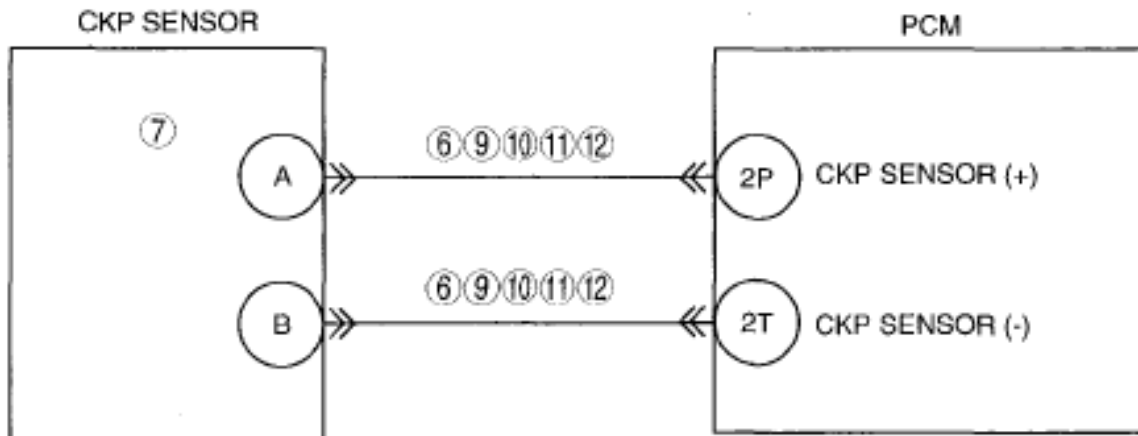

CKP SENSOR  
WIRING HARNESS-SIDE CONNECTOR

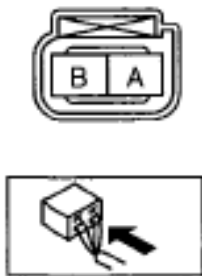

PCM  
WIRING HARNESS-SIDE CONNECTOR

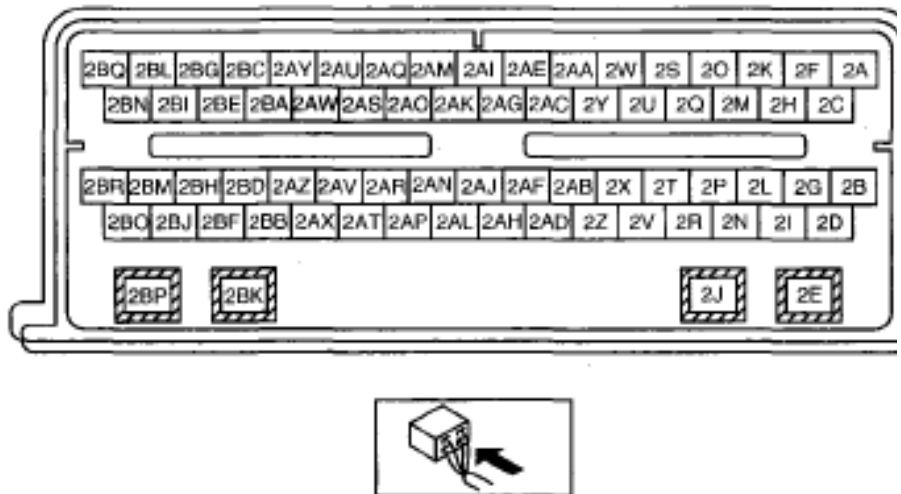

### DIAGNOSTIC PROCEDURE

#### DTC P0320 (MZI-3.5) DIAGNOSTIC PROCEDURE

STEP	INSPECTION		ACTION
1	<b>VERIFY FREEZE FRAME DATA HAS BEEN RECORDED</b> <ul style="list-style-type: none"> <li>Has FREEZE FRAME DATA been recorded?</li> </ul>	Yes	Go to the next step.
		No	Record FREEZE FRAME DATA on the repair order, then go to the next step.
2	<b>VERIFY RELATED REPAIR INFORMATION AVAILABILITY</b> <ul style="list-style-type: none"> <li>Verify related Service Bulletins</li> </ul>	Yes	Perform repair or diagnosis according to the available Service Bulletins. <ul style="list-style-type: none"> <li>If the vehicle is not repaired, go to</li> </ul>

## 2007 Mazda CX-9 Grand Touring

2007 ENGINE PERFORMANCE On-Board Diagnostic (MZI-3.5) - CX-9

	and/or on-line repair information availability.		the next step.
	<ul style="list-style-type: none"> <li>Is any related Service Bulletins available?</li> </ul>	No	Go to the next step.
3	<p><b>VERIFY RELATED PENDING CODE OR STORED DTCs</b></p> <ul style="list-style-type: none"> <li>Turn the ignition switch off then to the ON position (Engine off).</li> <li>Verify related pending code or stored DTCs.</li> <li>Are other DTCs present?</li> </ul>	Yes	Go to the appropriate DTC troubleshooting. (See <b><u>DTC TABLE [MZI-3.5]</u></b> .)
		No	Go to the next step.
4	<p><b>INSPECT CKP SENSOR SIGNAL SENT TO PCM</b></p> <p><b>NOTE:</b></p> <ul style="list-style-type: none"> <li>The battery should be fully charged and the starting system should be functioning properly.</li> <li>Disable the inertia switch.</li> <li>Turn the ignition switch to the ON position [(Engine off).</li> <li>Access the PCM and monitor the RPM PID.</li> <li>Crank the engine.</li> <li>Is the engine speed more than 150 rpm?</li> </ul>	Yes	Go to Step 13.
		No	Go to the next step.
5	<p><b>INSPECT TIMING COVER, CKP SENSOR AND EXTERNAL TRIGGER WHEEL (OUTSIDE TIMING COVER) FOR OBVIOUS PHYSICAL DAMAGE</b></p> <ul style="list-style-type: none"> <li>Visually check the timing cover, CKP sensor and external trigger wheel (outside the timing cover) for obvious physical damage.</li> <li>Do any parts appear physically damaged?</li> </ul>	Yes	Repair if necessary. Then go to Step 13.
		No	Go to Step.
6	<p><b>INSPECT FOR PROPER CKP BIAS VOLTAGES IN PCM</b></p> <ul style="list-style-type: none"> <li>Disconnect the CKP sensor</li> </ul>	Yes	Go to the next step.

## 2007 Mazda CX-9 Grand Touring

2007 ENGINE PERFORMANCE On-Board Diagnostic (MZI-3.5) - CX-9

	<p>connector.</p> <ul style="list-style-type: none"> <li>• Turn the ignition switch to the ON position [(Engine off).</li> <li>• Measure the voltage between: <ul style="list-style-type: none"> <li>○ CKP sensor terminal A on the wiring harness side and battery negative</li> <li>○ CKP sensor terminal B on the wiring harness side and battery negative</li> </ul> </li> <li>• Are the voltages between 1-3 V?</li> </ul>	No	Go to Step 8.
7	<p><b>INSPECT CKP SENSOR RESISTANCE</b></p> <ul style="list-style-type: none"> <li>• Turn the ignition switch off.</li> <li>• Measure the resistance between CKP sensor terminal A and B on the component side.</li> <li>• Is the resistance between 0.25-1 kilohms?</li> </ul>	Yes	Go to the next step.
		No	Replace the CKP sensor. Then go to Step 13.
8	<p><b>INSPECT CKP WIRING HARNESS SHIELD CIRCUIT FOR SHORT TO GROUND</b></p> <p><b>NOTE:</b></p> <ul style="list-style-type: none"> <li>• <b>The wiring harness shield protects the CKP signal from electrical noise and is grounded at one end, typically near the PCM.</b></li> </ul> <p><b>NOTE:</b></p> <ul style="list-style-type: none"> <li>• <b>Perform the following resistance measurement between the CKP shield and the ground.</b></li> <li>• Measure the resistance between: <ul style="list-style-type: none"> <li>○ CKP_SHLD assembly connector wiring harness side and ground</li> </ul> </li> <li>• Is the resistance less than 5 ohms?</li> </ul>	Yes	Go to the next step.
		No	Repair the short circuit. Check for a poor ground. Then go to Step 13.
9	<p><b>INSPECT FOR SHORT BETWEEN CKP (+) AND CKP (-) IN WIRING HARNESS</b></p>	Yes	Go to the next step.



## 2007 Mazda CX-9 Grand Touring

2007 ENGINE PERFORMANCE On-Board Diagnostic (MZI-3.5) - CX-9

	<ul style="list-style-type: none"> <li>• Turn the ignition switch off.</li> <li>• Disconnect the PCM connector.</li> <li>• Measure the resistance between:             <ul style="list-style-type: none"> <li>○ CKP sensor terminal A and B on the wiring harness side</li> </ul> </li> <li>• Is the resistance more than 10 kilohms?</li> </ul>	No	Repair or replace suspected part, Then go to Step 13.
10	<b>INSPECT CKP CIRCUIT(S) FOR OPEN CIRCUIT IN WIRING HARNESS</b> <ul style="list-style-type: none"> <li>• Measure the resistance between:             <ul style="list-style-type: none"> <li>○ CKP sensor connector A on the wiring harness side and PCM terminal 2P</li> <li>○ CKP sensor connector B on the wiring harness side and PCM terminal 2T</li> </ul> </li> <li>• Are the resistances less than 5 ohms?</li> </ul>	Yes	Go to the next step.
		No	Repair or replace suspected part, Then go to Step 13.
11	<b>INSPECT CKP CIRCUIT(S) FOR SHORT TO GROUND IN WIRING HARNESS</b> <ul style="list-style-type: none"> <li>• Measure the resistance between:             <ul style="list-style-type: none"> <li>○ CKP sensor connector A on the wiring harness side and battery negative</li> <li>○ CKP sensor connector B on the wiring harness side and battery negative</li> </ul> </li> <li>• Are the resistances more than 10 kilohms?</li> </ul>	Yes	Go to the next step.
		No	Repair or replace suspected part, Then go to Step 13.
12	<b>INSPECT CKP CIRCUIT FOR SHORT TO VOLTAGE IN WIRING HARNESS</b> <ul style="list-style-type: none"> <li>• Turn the ignition switch to the ON position (Engine off).</li> <li>• Measure the voltage between:             <ul style="list-style-type: none"> <li>○ CKP sensor connector A on the wiring harness side and battery negative</li> </ul> </li> </ul>	Yes	Repair or replace suspected part, Then go to Step 13.
		No	Go to the next step.

## 2007 Mazda CX-9 Grand Touring

2007 ENGINE PERFORMANCE On-Board Diagnostic (MZI-3.5) - CX-9

	<ul style="list-style-type: none"> <li>○ CKP sensor connector B on the wiring harness side and battery negative</li> <li>● Are any voltage present?</li> </ul>		
13	<p><b>VERIFY TROUBLESHOOTING OF DTC P0320 HAS BEEN COMPLETED</b></p> <ul style="list-style-type: none"> <li>● Verify that all disconnected connectors are reconnected.</li> <li>● Turn the ignition switch to the ON position (Engine off).</li> <li>● Clear the DTC from the PCM memory using the M-MDS.</li> <li>● Start the engine and run it at idle.</li> <li>● Retrieve DTCs using the M-MDS.</li> <li>● Is the PENDING CODE for this DTC present?</li> </ul>	Yes	Replace the PCM, then go to the next step. (see <b>PCM REMOVAL/INSTALLATION [MZI-3.5]</b> .)
		No	Go to the next step.
14	<p><b>VERIFY AFTER REPAIR PROCEDURE</b></p> <ul style="list-style-type: none"> <li>● Perform the "AFTER REPAIR PROCEDURE".</li> </ul> <p>(See <b>AFTER REPAIR PROCEDURE [MZI-3.5]</b>.)</p> <ul style="list-style-type: none"> <li>● Are any DTCs present?</li> </ul>	Yes	Go to the applicable DTC inspection. (See <b>DTC TABLE [MZI-3.5]</b> .)
		No	Troubleshooting completed.

### DTC P0325 [MZI-3.5]

#### DTC P0325 (MZI-3.5) DETECTION CONDITION AND POSSIBLE CAUSES

DTC P0325	KS circuit (RH)
<b>DETECTION CONDITION</b>	<ul style="list-style-type: none"> <li>● The KS detects vibrations upon increase and decrease in engine RPM. The KS generates a voltage based on this vibration. A DTC is set if the voltage goes outside calibrated level.</li> </ul>
<b>POSSIBLE CAUSE</b>	<ul style="list-style-type: none"> <li>● Open circuit wiring harness between KS terminal C and PCM terminal 2L</li> <li>● Short to power supply in wiring harness between KS terminal C and PCM terminal 2L</li> <li>● Short to ground circuit between KS terminal C and PCM terminal 2L</li> <li>● Open circuit wiring harness between KS terminal D and PCM terminal 2G</li> <li>● Short to power supply in wiring harness between KS terminal D and PCM terminal 2G</li> <li>● Short to ground circuit between KS terminal D and PCM terminal 2G</li> </ul>

## 2007 Mazda CX-9 Grand Touring

2007 ENGINE PERFORMANCE On-Board Diagnostic (MZI-3.5) - CX-9

- Connector or terminal malfunction
- KS malfunction

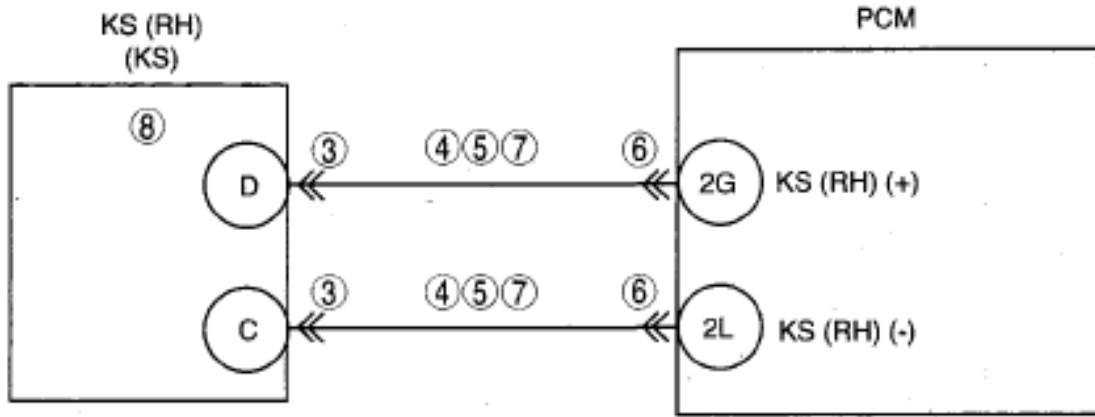

KS  
WIRING HARNESS-SIDE CONNECTOR

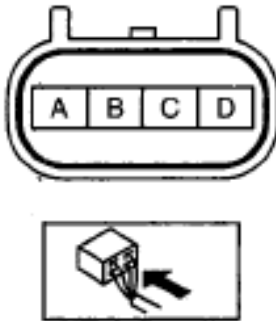

PCM  
WIRING HARNESS-SIDE CONNECTOR

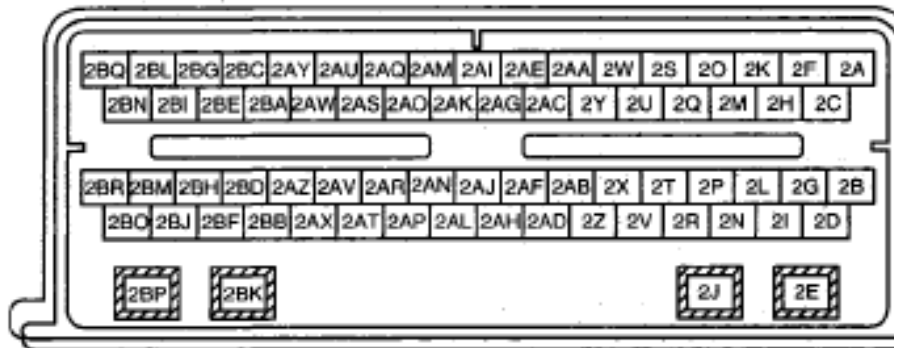

### DIAGNOSTIC PROCEDURE

#### DTC P0325 (MZI-3.5) DIAGNOSTIC PROCEDURE

STEP	INSPECTION		ACTION
1	<b>VERIFY FREEZE FRAME DATA HAS BEEN RECORDED</b> <ul style="list-style-type: none"> <li>• Has FREEZE FRAME DATA been recorded?</li> </ul>	Yes	Go to the next step.
		No	Record FREEZE FRAME DATA on the repair order, then go to the next step.
2	<b>VERIFY RELATED REPAIR INFORMATION AVAILABILITY</b>	Yes	Perform repair or diagnosis according to the available Service Bulletins.

## 2007 Mazda CX-9 Grand Touring

2007 ENGINE PERFORMANCE On-Board Diagnostic (MZI-3.5) - CX-9

	<ul style="list-style-type: none"> <li>• Verify related Service Bulletins and/or on-line repair information availability.</li> <li>• Is any related Service Bulletins available?</li> </ul>		<ul style="list-style-type: none"> <li>• If the vehicle is not repaired, go to the next step.</li> </ul>
		No	Go to the next step.
3	<b>INSPECT KS CONNECTOR FOR POOR CONNECTION</b> <ul style="list-style-type: none"> <li>• Turn the ignition switch off.</li> <li>• Disconnect the KS connector.</li> <li>• Inspect for poor connection (such as damaged/pulled-out pins, corrosion).</li> <li>• Are there any malfunction?</li> </ul>	Yes	Repair or replace suspected part, then go to Step 9.
		No	Go to the next step.
4	<b>INSPECT KS (RH) SIGNAL CIRCUIT FOR SHORT TO POWER SUPPLY</b> <ul style="list-style-type: none"> <li>• Turn the ignition switch to the ON position (Engine off).</li> <li>• Measure the voltage between the following terminals:                             <ul style="list-style-type: none"> <li>○ KS terminal C and body ground.</li> <li>○ KS terminal D and body ground.</li> </ul> </li> <li>• Are the voltage B+?</li> </ul>	Yes	Repair or replace suspected part, then go to Step 9.
		No	Go to the next step.
5	<b>INSPECT KS (RH) CIRCUIT FOR SHORT TO GROUND</b> <ul style="list-style-type: none"> <li>• Turn the ignition switch to the ON position (Engine off).</li> <li>• Inspect for continuity between the following terminals:                             <ul style="list-style-type: none"> <li>○ KS terminal C and body ground.</li> <li>○ KS terminal D and body ground.</li> </ul> </li> <li>• Are there continuity?</li> </ul>	Yes	Repair or replace suspected part, then go to Step 9.
		No	Go to the next step.
6	<b>INSPECT PCM CONNECTOR FOR POOR CONNECTION</b> <ul style="list-style-type: none"> <li>• Turn the ignition switch off.</li> </ul>	Yes	Repair or replace suspected part, then go to Step 9.

## 2007 Mazda CX-9 Grand Touring

2007 ENGINE PERFORMANCE On-Board Diagnostic (MZI-3.5) - CX-9

	<ul style="list-style-type: none"> <li>• Disconnect the PCM sensor connector.</li> <li>• Inspect for poor connection (such as damaged/pulled-out pins, corrosion).</li> <li>• Are there any malfunction?</li> </ul>	No	Go to the next step.
7	<b>INSPECT KS (RH) CIRCUIT FOR OPEN CIRCUIT</b> <ul style="list-style-type: none"> <li>• Turn the ignition switch off.</li> <li>• Inspect for continuity between the following terminals: <ul style="list-style-type: none"> <li>○ KS terminal C and PCM terminal 2L</li> <li>○ KS terminal D and PCM terminal 2G</li> </ul> </li> <li>• Is there continuity?</li> </ul>	Yes	Go to the next step.
		No	Repair or replace suspected part, then go to Step 9.
8	<b>INSPECT THE KS (RH)</b> <ul style="list-style-type: none"> <li>• Inspect the KS (RH).</li> </ul> <p>(see <b><u>KNOCK SENSOR (KS) INSPECTION [MZI-3.5].</u></b>)</p> <ul style="list-style-type: none"> <li>• Is there malfunction?</li> </ul>	Yes	Replace the KS, then go to the next step. (see <b><u>KNOCK SENSOR (KS) REMOVAL/INSTALLATION [MZI-3.5].</u></b> )
		No	Go to the next step.
9	<b>VERIFY TROUBLESHOOTING OF DTC P0325 HAS BEEN COMPLETED</b> <ul style="list-style-type: none"> <li>• Verify that all disconnected connectors reconnected.</li> <li>• Clear the DTC from the PCM memory using the M-MDS.</li> <li>• Perform the "KOEO or KOER self-test" using the M-MDS.</li> </ul> <p>(See <b><u>KOEO/KOER SELF TEST [MZI-3.5].</u></b>)</p> <ul style="list-style-type: none"> <li>• Is the PENDING CODE for the DTC present?</li> </ul>	Yes	Replace the PCM, then go to the next step. (see <b><u>PCM REMOVAL/INSTALLATION [MZI-3.5].</u></b> )
		No	Go to the next step.
10	<b>VERIFY AFTER REPAIR PROCEDURE</b>	Yes	Go to the applicable DTC inspection. (See <b><u>DTC TABLE [MZI-3.5].</u></b> )

## 2007 Mazda CX-9 Grand Touring

2007 ENGINE PERFORMANCE On-Board Diagnostic (MZI-3.5) - CX-9

	<ul style="list-style-type: none"><li>• Perform the "AFTER REPAIR PROCEDURE".</li></ul> <p>(See <b><u>AFTER REPAIR PROCEDURE [MZI-3.5]</u></b>.)</p> <ul style="list-style-type: none"><li>• Are any DTC present?</li></ul>	No	Troubleshooting completed.
--	---	----	----------------------------

### DTC P0330 [MZI-3.5]

#### DTC P0330 (MZI-3.5) DETECTION CONDITION AND POSSIBLE CAUSES

DTC P0330	KS circuit (LH)
<b>DETECTION CONDITION</b>	<ul style="list-style-type: none"><li>• The KS detects vibrations upon increase and decrease in engine RPM. The KS generates a voltage based on this vibration. A DTC is set if the voltage goes outside calibrated level.</li></ul>
<b>POSSIBLE CAUSE</b>	<ul style="list-style-type: none"><li>• Open circuit wiring harness between KS terminal A and PCM terminal 2Q</li><li>• Short to power supply in wiring harness between KS terminal A and PCM terminal 2Q</li><li>• Short to ground circuit between KS terminal A and PCM terminal 2Q</li><li>• Open circuit wiring harness between KS terminal B and PCM terminal 2M</li><li>• Short to power supply in wiring harness between KS terminal B and PCM terminal 2M</li><li>• Short to ground circuit between KS terminal B and PCM terminal 2M</li><li>• Connector or terminal malfunction</li><li>• KS malfunction</li></ul>

## 2007 Mazda CX-9 Grand Touring

2007 ENGINE PERFORMANCE On-Board Diagnostic (MZI-3.5) - CX-9

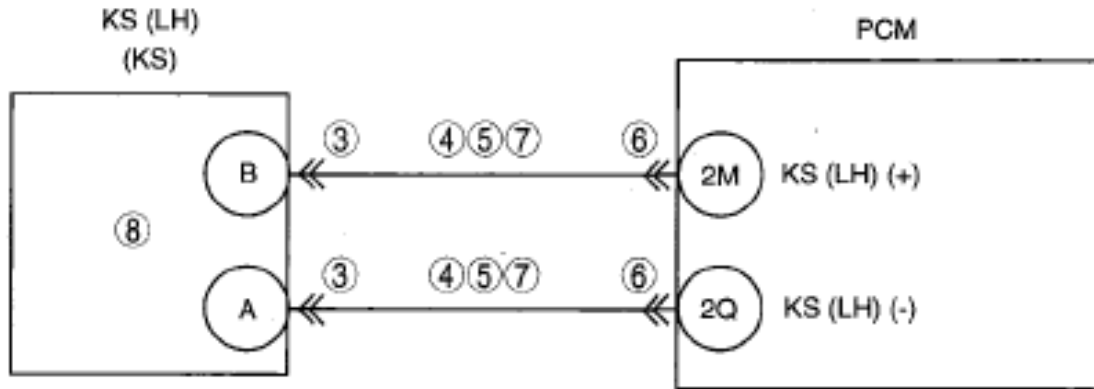

KS  
WIRING HARNESS-SIDE CONNECTOR

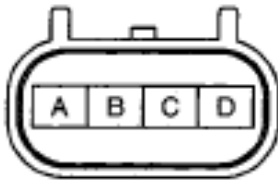

PCM  
WIRING HARNESS-SIDE CONNECTOR

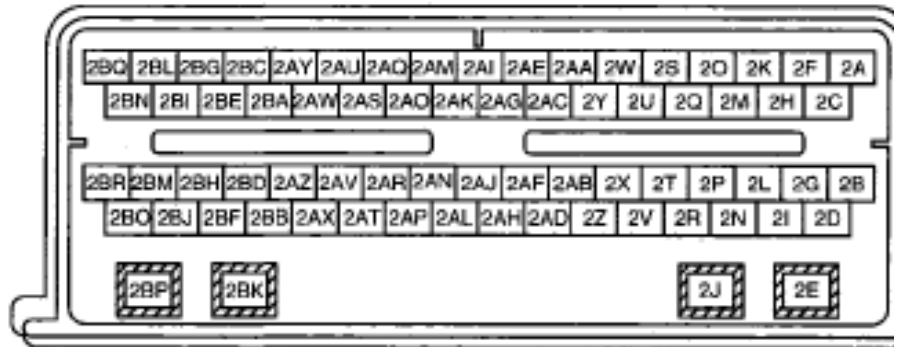

### DIAGNOSTIC PROCEDURE

#### DTC P0330 (MZI-3.5) DIAGNOSTIC PROCEDURE

STEP	INSPECTION		ACTION
1	<b>VERIFY FREEZE FRAME DATA HAS BEEN RECORDED</b>  • Has FREEZE FRAME DATA been recorded?	Yes	Go to the next step.
		No	Record FREEZE FRAME DATA on the repair order, then go to the next step.
2	<b>VERIFY RELATED REPAIR INFORMATION AVAILABILITY</b>  • Verify related Service Bulletins	Yes	Perform repair or diagnosis according to the available Service Bulletins.  • If the vehicle is not repaired, go to

## 2007 Mazda CX-9 Grand Touring

2007 ENGINE PERFORMANCE On-Board Diagnostic (MZI-3.5) - CX-9

	and/or on-line repair information availability.		the next step.
	<ul style="list-style-type: none"> <li>• Is any related Service Bulletins available?</li> </ul>	No	Go to the next step.
3	<p><b>INSPECT KS CONNECTOR FOR POOR CONNECTION</b></p> <ul style="list-style-type: none"> <li>• Turn the ignition switch off.</li> <li>• Disconnect the KS connector.</li> <li>• Inspect for poor connection (such as damaged/pulled-out pins, corrosion).</li> <li>• Are there any malfunction?</li> </ul>	Yes	Repair or replace suspected part, then go to Step 9.
		No	Go to the next step.
4	<p><b>INSPECT KS (LH) SIGNAL CIRCUIT FOR SHORT TO POWER SUPPLY</b></p> <ul style="list-style-type: none"> <li>• Turn the ignition switch to the ON position (Engine off).</li> <li>• Measure the voltage between the following terminals:                             <ul style="list-style-type: none"> <li>○ KS terminal A and body ground.</li> <li>○ KS terminal B and body ground.</li> </ul> </li> <li>• Are there voltage B+?</li> </ul>	Yes	Repair or replace suspected part, then go to Step 9.
		No	Go to the next step.
5	<p><b>INSPECT KS (LH) CIRCUIT FOR SHORT TO GROUND</b></p> <ul style="list-style-type: none"> <li>• Turn the ignition switch to the ON position (Engine off).</li> <li>• Inspect for continuity between the following terminals:                             <ul style="list-style-type: none"> <li>○ KS terminal A and body ground.</li> <li>○ KS terminal B and body ground.</li> </ul> </li> <li>• Are there continuity?</li> </ul>	Yes	Repair or replace suspected part, then go to Step 9.
		No	Go to the next step.
6	<p><b>INSPECT PCM CONNECTOR FOR POOR CONNECTION</b></p> <ul style="list-style-type: none"> <li>• Turn the ignition switch off.</li> <li>• Disconnect the PCM sensor</li> </ul>	Yes	Repair or replace suspected part, then go to Step 9.



## 2007 Mazda CX-9 Grand Touring

2007 ENGINE PERFORMANCE On-Board Diagnostic (MZI-3.5) - CX-9

	<p>connector.</p> <ul style="list-style-type: none"> <li>Inspect for poor connection (such as damaged/pulled-out pins, corrosion).</li> <li>Are there any malfunction?</li> </ul>	No	Go to the next step.
7	<p><b>INSPECT KS (LH) CIRCUIT FOR OPEN CIRCUIT</b></p> <ul style="list-style-type: none"> <li>Turn the ignition switch off.</li> <li>Inspect for continuity between the following terminals: <ul style="list-style-type: none"> <li>KS terminal A and PCM terminal 2Q</li> <li>KS terminal B and PCM terminal 2M</li> </ul> </li> <li>Are there continuity?</li> </ul>	Yes	Go to the next step.
		No	Repair or replace suspected part, then go to Step 9.
8	<p><b>INSPECT THE KS (LH)</b></p> <ul style="list-style-type: none"> <li>Inspect the KS (LH).</li> </ul> <p>(see <b><u>KNOCK SENSOR (KS) INSPECTION [MZI-3.5].</u></b>)</p> <ul style="list-style-type: none"> <li>Is there malfunction?</li> </ul>	Yes	Replace the KS, then go to the next step. (see <b><u>KNOCK SENSOR (KS) REMOVAL/INSTALLATION [MZI-3.5].</u></b> )
		No	Go to the next step.
9	<p><b>VERIFY TROUBLESHOOTING OF DTC P0330 HAS BEEN COMPLETED</b></p> <ul style="list-style-type: none"> <li>Verify that all disconnected connectors reconnected.</li> <li>Clear the DTC from the PCM memory using the M-MDS.</li> <li>Perform the "KOEO or KOER self-test" using the M-MDS.</li> </ul> <p>(See <b><u>KOEO/KOER SELF TEST [MZI-3.5].</u></b>)</p> <ul style="list-style-type: none"> <li>Is the PENDING CODE for the DTC present?</li> </ul>	Yes	Replace the PCM, then go to the next step. (see <b><u>PCM REMOVAL/INSTALLATION [MZI-3.5].</u></b> )
		No	Go to the next step.
10	<p><b>VERIFY AFTER REPAIR PROCEDURE</b></p> <ul style="list-style-type: none"> <li>Perform the "AFTER REPAIR</li> </ul>	Yes	Go to the applicable DTC inspection. (See <b><u>DTC TABLE [MZI-3.5].</u></b> )

## 2007 Mazda CX-9 Grand Touring

2007 ENGINE PERFORMANCE On-Board Diagnostic (MZI-3.5) - CX-9

<p>PROCEDURE".</p> <p>(See <b><u>AFTER REPAIR PROCEDURE [MZI-3.5].</u></b>)</p> <ul style="list-style-type: none"> <li>• Are any DTC present?</li> </ul>	No	Troubleshooting completed.
--	----	----------------------------

### DTC P0340 [MZI-3.5]

#### DTC P0340 (MZI-3.5) DETECTION CONDITION AND POSSIBLE CAUSES

<b>DTC P0340</b>	<b>CMP sensor (RH) circuit</b>
<b>DETECTION CONDITION</b>	<ul style="list-style-type: none"> <li>• The test fails when the PCM can no longer detect the signal from the CMP sensor (RH).</li> </ul>
<b>POSSIBLE CAUSE</b>	<ul style="list-style-type: none"> <li>• Connector or terminal malfunction</li> <li>• CMP sensor (RH) malfunction</li> <li>• Short to ground circuit between CMP sensor (RH) terminal A and PCM terminal 1</li> <li>• Short to power supply between CMP sensor (RH) terminal A and PCM terminal 2</li> <li>• Open circuit between CMP sensor (RH) terminal A and PCM terminal 2X</li> <li>• Open circuit between CMP sensor (RH) terminal B and PCM terminal 2C</li> <li>• PCM malfunction</li> </ul>

## 2007 Mazda CX-9 Grand Touring

2007 ENGINE PERFORMANCE On-Board Diagnostic (MZI-3.5) - CX-9

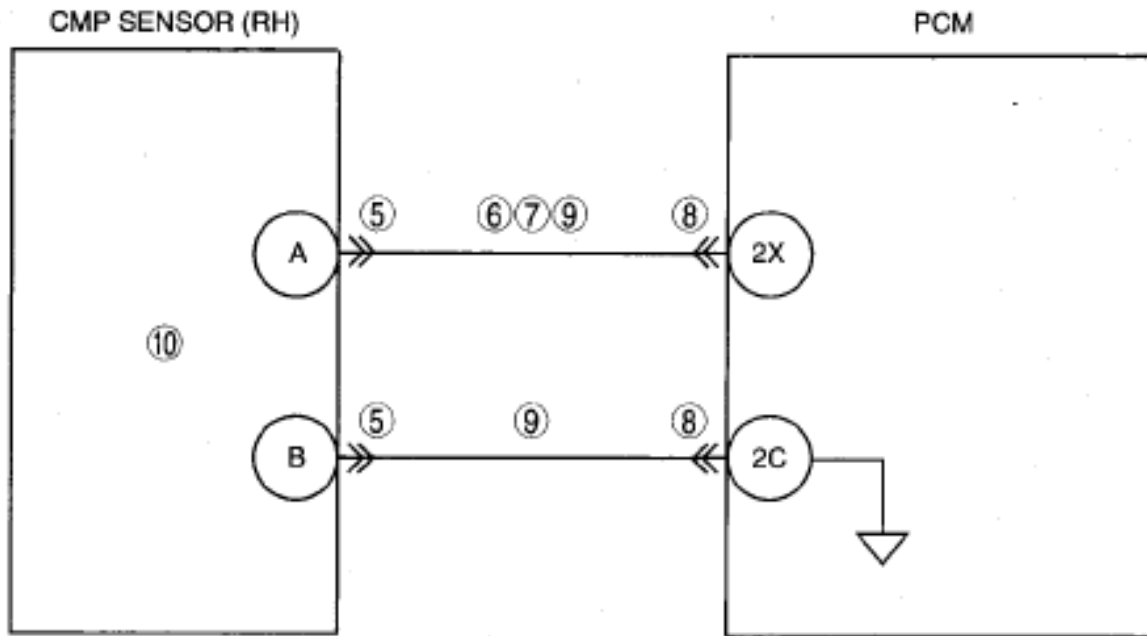

PCM  
WIRING HARNESS-SIDE CONNECTOR

CMP SENSOR (RH)  
WIRING HARNESS-SIDE CONNECTOR

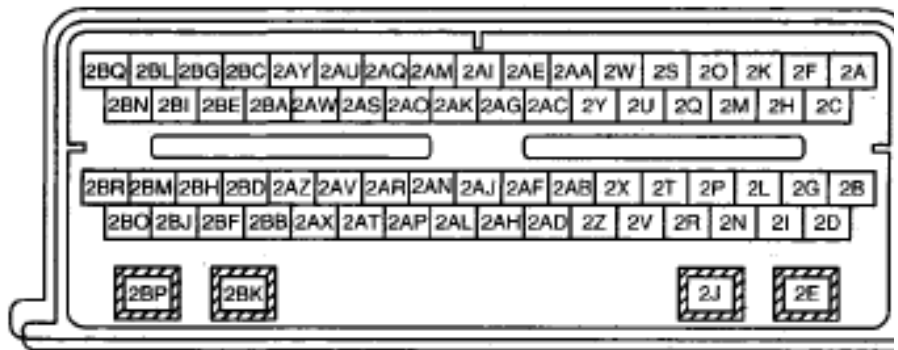
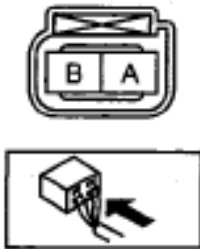

### DIAGNOSTIC PROCEDURE

#### DTC P0340 (MZI-3.5) DIAGNOSTIC PROCEDURE

STEP	INSPECTION		ACTION
1	<b>VERIFY FREEZE FRAME DATA HAS BEEN RECORDED</b>	Yes	Go to the next step.
		No	Record FREEZE FRAME DATA on the repair order, then go to the next step.
	<ul style="list-style-type: none"> <li>Has FREEZE FRAME DATA</li> </ul>		

## 2007 Mazda CX-9 Grand Touring

2007 ENGINE PERFORMANCE On-Board Diagnostic (MZI-3.5) - CX-9

	been recorded?		
2	<b>VERIFY RELATED REPAIR INFORMATION AVAILABILITY</b> <ul style="list-style-type: none"> <li>• Verify related Service Bulletins and/or on-line repair information availability.</li> <li>• Is any related Service Bulletins available?</li> </ul>	Yes	Perform repair or diagnosis according to the available Service Bulletins. <ul style="list-style-type: none"> <li>• If the vehicle is not repaired, go to the next step.</li> </ul>
		No	Go to the next step.
3	<b>CLEAR AND ATTEMPT TO RETRIEVE THE DTC</b> <p><b>NOTE:</b></p> <ul style="list-style-type: none"> <li>• If DTCs <b>P0340, P0344, P0345 or P0349</b> are present, <b>ignition, alternator noise, radio frequency interference and CKP concerns should be considered.</b></li> <li>• Clear the DTC from the PCM memory using the M-MDS.</li> <li>• Turn the ignition switch to the ON position (Engine running).</li> <li>• Increase engine speed to <b>more than 1,500 rpm for 10s.</b> Repeat this <b>3 times.</b></li> <li>• Retrieve the continuous memory DTCs.</li> <li>• The same DTC present?</li> </ul>	Yes	Go to the next step.
		No	Perform the "INTERMITTENT CONCERN TROUBLESHOOTING". Then go to Step 11.
4	<b>CHECK THE GENERATOR FOR EXCESSIVE ELECTRICAL NOISE</b> <p><b>NOTE:</b></p> <ul style="list-style-type: none"> <li>• If the generator/regulator is electrically noisy, the noise decreases when the terminal B is disconnected.</li> <li>• Turn the ignition switch to the ON position (Engine running).</li> <li>• Monitor the generator for an audible electric noise.</li> <li>• Turn the ignition switch off.</li> <li>• Generator/regulator terminal B</li> </ul>	Yes	Go to the next step.
		No	<ul style="list-style-type: none"> <li>• Inspect the charging system, then go to Step 11.                             <ul style="list-style-type: none"> <li>○ Drive belt damaged and misinstallation</li> <li>○ Generator pulley or generator misinstallation</li> </ul> </li> </ul>

## 2007 Mazda CX-9 Grand Touring

2007 ENGINE PERFORMANCE On-Board Diagnostic (MZI-3.5) - CX-9

	<p>disconnected.</p> <ul style="list-style-type: none"> <li>• Turn the ignition switch to the ON position (Engine running).</li> <li>• With the engine running, determine if the generator is still noisy.</li> <li>• Does the noise remain constant when the terminal B is disconnected?</li> </ul>		
5	<p><b>INSPECT CMP SENSOR (RH) CONNECTOR FOR POOR CONNECTION</b></p> <ul style="list-style-type: none"> <li>• Turn the ignition switch off.</li> <li>• Disconnect the CMP sensor (RH) connector.</li> <li>• Inspect for poor connection (such as damaged/pulled-out pins, corrosion).</li> <li>• Are there any malfunction?</li> </ul>	Yes	Repair or replace suspected part, then go to Step 11.
		No	Go to the next step.
6	<p><b>INSPECT CMP SENSOR SIGNAL CIRCUIT FOR SHORT TO POWER SUPPLY</b></p> <ul style="list-style-type: none"> <li>• Turn the ignition switch to the ON position (Engine off).</li> <li>• Measure voltage between CMP sensor (RH) terminal A (wiring harness-side) and body ground.</li> <li>• Is the voltage <b>B+</b> ?</li> </ul>	Yes	Repair or replace suspected part, then go to Step 11.
		No	Go to the next step.
7	<p><b>INSPECT CMP SENSOR (RH) SIGNAL CIRCUIT FOR SHORT TO GROUND</b></p> <ul style="list-style-type: none"> <li>• Turn the ignition switch off.</li> <li>• Check continuity between CMP sensor (RH) terminal A and body ground.</li> <li>• Is there continuity?</li> </ul>	Yes	Repair or replace suspected part, then go to Step 11.
		No	Go to the next step.
8	<p><b>INSPECT PCM CONNECTOR FOR POOR CONNECTION</b></p> <ul style="list-style-type: none"> <li>• Turn the ignition switch off.</li> </ul>	Yes	Repair or replace suspected part, then go to Step 11.

## 2007 Mazda CX-9 Grand Touring

2007 ENGINE PERFORMANCE On-Board Diagnostic (MZI-3.5) - CX-9

	<ul style="list-style-type: none"> <li>• Disconnect PCM connector.</li> <li>• Check for poor connection (such as damaged, pulled-out pins, and corrosion).</li> <li>• Are there any malfunction?</li> </ul>	No	Go to the next step.
9	<b>INSPECT CMP SENSOR (RH) CIRCUIT FOR OPEN CIRCUIT</b> <ul style="list-style-type: none"> <li>• Turn the ignition switch off.</li> <li>• Check continuity between the following circuits:                             <ul style="list-style-type: none"> <li>○ CMP sensor (RH) terminal A and PCM terminal 2X</li> <li>○ CMP sensor (RH) terminal B and PCM terminal 2C</li> </ul> </li> <li>• Is there continuity?</li> </ul>	Yes	Go to the next step.
		No	Repair or replace suspected part, then go to Step 11.
10	<b>INSPECT CMP SENSOR (RH)</b> <ul style="list-style-type: none"> <li>• Inspect CMP sensor (RH).</li> </ul> <p>(see <b><u>CAMSHAFT POSITION (CMP) SENSOR INSPECTION [MZI-3.5].</u></b>)</p> <ul style="list-style-type: none"> <li>• Is there any malfunction?</li> </ul>	Yes	Replace CMP sensor (RH), then go to the next step. (see <b><u>CAMSHAFT POSITION (CMP) SENSOR REMOVAL/INSTALLATION [MZI-3.5].</u></b> )
		No	Go to the next step.
11	<b>VERIFY TROUBLESHOOTING OF DTC P0340 COMPLETED</b> <ul style="list-style-type: none"> <li>• Verify that all disconnected connectors reconnected.</li> <li>• Turn ignition switch to the ON position (Engine off).</li> <li>• Clear the DTC from the PCM memory using the M-MDS.</li> <li>• Start the engine.</li> <li>• Access the MAF PID using the M-MDS.</li> <li>• Is same DTC present?</li> </ul>	Yes	Replace the PCM, then go to the next step. (see <b><u>PCM REMOVAL/INSTALLATION [MZI-3.5].</u></b> )
		No	Go to the next step.
12	<b>VERIFY AFTER REPAIR PROCEDURE</b> <ul style="list-style-type: none"> <li>• Perform the "AFTER REPAIR PROCEDURE".</li> </ul>	Yes	Go to the applicable DTC inspection. (See <b><u>DTC TABLE [MZI-3.5].</u></b> )

## 2007 Mazda CX-9 Grand Touring

2007 ENGINE PERFORMANCE On-Board Diagnostic (MZI-3.5) - CX-9

<p>(See <b>AFTER REPAIR PROCEDURE [MZI-3.5].</b>)</p> <ul style="list-style-type: none"><li>• Are any DTC present?</li></ul>	No	Troubleshooting completed.
--	----	----------------------------

### DTC P0344 [MZI-3.5]

#### DTC P0344 (MZI-3.5) DETECTION CONDITION AND POSSIBLE CAUSES

<b>DTC P0344</b>	<b>CMP sensor (RH) circuit intermittent</b>
<b>DETECTION CONDITION</b>	<ul style="list-style-type: none"><li>• The test fails when the PCM detects an intermittent signal from the CMP sensor.</li></ul>
<b>POSSIBLE CAUSE</b>	<ul style="list-style-type: none"><li>• Connector or terminal malfunction</li><li>• CMP sensor (RH) malfunction</li><li>• Sensor shielding malfunction</li><li>• Short to ground circuit between CMP sensor (RH) terminal A and PCM terminal 2</li><li>• Short to power supply between CMP sensor (RH) terminal A and PCM terminal 2</li><li>• Open circuit between CMP sensor (RH) terminal A and PCM terminal 2X</li><li>• Open circuit between CMP sensor (RH) terminal B and PCM terminal 2C</li></ul>

## 2007 Mazda CX-9 Grand Touring

2007 ENGINE PERFORMANCE On-Board Diagnostic (MZI-3.5) - CX-9

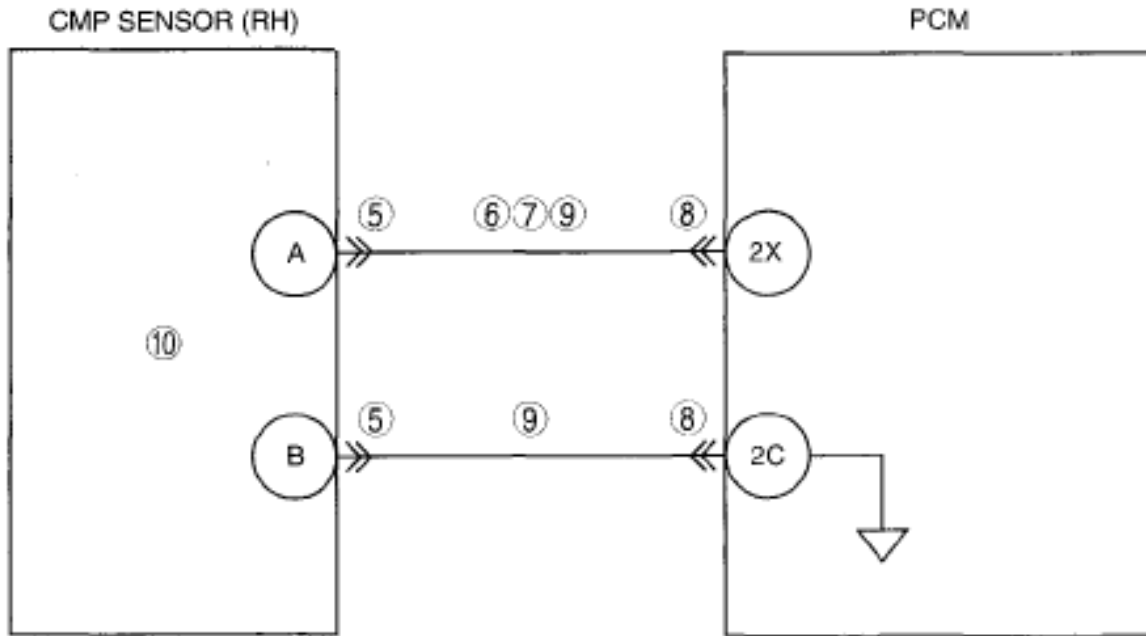

PCM  
WIRING HARNESS-SIDE CONNECTOR

CMP SENSOR (RH)  
WIRING HARNESS-SIDE CONNECTOR

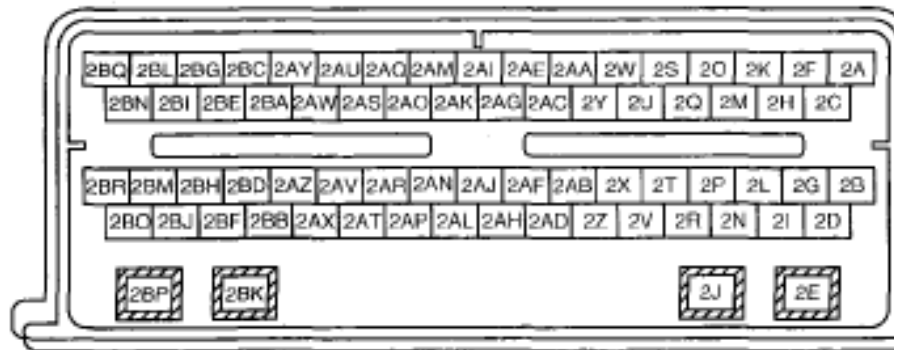

### DIAGNOSTIC PROCEDURE

#### DTC P0344 (MZI-3.5) DIAGNOSTIC PROCEDURE

STEP	INSPECTION	ACTION	
1	<b>VERIFY FREEZE FRAME DATA HAS BEEN RECORDED</b>	Yes	Go to the next step.
		No	Record FREEZE FRAME DATA on the repair order, then go to the next step.
	<ul style="list-style-type: none"> <li>Has FREEZE FRAME DATA</li> </ul>		



## 2007 Mazda CX-9 Grand Touring

2007 ENGINE PERFORMANCE On-Board Diagnostic (MZI-3.5) - CX-9

	been recorded?		
2	<b>VERIFY RELATED REPAIR INFORMATION AVAILABILITY</b> <ul style="list-style-type: none"> <li>• Verify related Service Bulletins and/or on-line repair information availability.</li> <li>• Is any related Service Bulletins available?</li> </ul>	Yes	Perform repair or diagnosis according to the available Service Bulletins. <ul style="list-style-type: none"> <li>• If the vehicle is not repaired, go to the next step.</li> </ul>
		No	Go to the next step.
3	<b>CLEAR AND ATTEMPT TO RETRIEVE THE DTC</b> <p><b>NOTE:</b></p> <ul style="list-style-type: none"> <li>• If DTCs P0340, P0344, P0345 or P0349 are present, ignition, alternator noise, radio frequency interference and CKP concerns should be considered.</li> <li>• Clear the DTC from the PCM memory using the M-MDS.</li> <li>• Turn the ignition switch to the ON position (Engine running).</li> <li>• Increase engine speed to <b>more than 1,500 rpm for 10s</b>. Repeat this <b>3 times</b>.</li> <li>• Retrieve the continuous memory DTCs.</li> <li>• The same DTC present?</li> </ul>	Yes	Go to the next step.
		No	Perform the "INTERMITTENT CONCERN TROUBLESHOOTING". Then go to Step 11.
4	<b>CHECK THE GENERATOR FOR EXCESSIVE ELECTRICAL NOISE</b> <p><b>NOTE:</b></p> <ul style="list-style-type: none"> <li>• If the generator/regulator is electrically noisy, the noise decreases when the terminal B is disconnected.</li> <li>• Turn the ignition switch to the ON position (Engine running).</li> <li>• Monitor the generator for an audible electric noise.</li> <li>• Turn the ignition switch off.</li> <li>• Generator/regulator terminal B</li> </ul>	Yes	Go to the next step.
		No	<ul style="list-style-type: none"> <li>• Inspect the charging system, then go to Step 11.                             <ul style="list-style-type: none"> <li>○ Drive belt damaged and misinstallation</li> <li>○ Generator pulley or generator misinstallation</li> </ul> </li> </ul>

## 2007 Mazda CX-9 Grand Touring

2007 ENGINE PERFORMANCE On-Board Diagnostic (MZI-3.5) - CX-9

	<p>disconnected.</p> <ul style="list-style-type: none"> <li>• Turn the ignition switch to the ON position (Engine running).</li> <li>• With the engine running, determine if the generator is still noisy.</li> <li>• Does the noise remain constant when the terminal B is disconnected?</li> </ul>		
5	<p><b>INSPECT CMP SENSOR (RH) CONNECTOR FOR POOR CONNECTION</b></p> <ul style="list-style-type: none"> <li>• Turn the ignition switch off.</li> <li>• Disconnect the CMP sensor (RH) connector.</li> <li>• Inspect for poor connection (such as damaged/pulled-out pins, corrosion).</li> <li>• Are there any malfunction?</li> </ul>	Yes	Repair or replace suspected part, then go to Step 11.
		No	Go to the next step.
6	<p><b>INSPECT CMP SENSOR SIGNAL CIRCUIT FOR SHORT TO POWER SUPPLY</b></p> <ul style="list-style-type: none"> <li>• Turn the ignition switch to the ON position (Engine off).</li> <li>• Measure voltage between CMP sensor (RH) terminal A (wiring harness-side) and body ground.</li> <li>• Is the voltage <b>B+</b> ?</li> </ul>	Yes	Repair or replace suspected part, then go to Step 11.
		No	Go to the next step.
7	<p><b>INSPECT CMP SENSOR (RH) SIGNAL CIRCUIT FOR SHORT TO GROUND</b></p> <ul style="list-style-type: none"> <li>• Turn the ignition switch off.</li> <li>• Check continuity between CMP sensor (RH) terminal A and body ground.</li> <li>• Is there continuity?</li> </ul>	Yes	Repair or replace suspected part, then go to Step 11.
		No	Go to the next step.
8	<p><b>INSPECT PCM CONNECTOR FOR POOR CONNECTION</b></p> <ul style="list-style-type: none"> <li>• Turn the ignition switch off.</li> </ul>	Yes	Repair or replace suspected part, then go to Step 11.

## 2007 Mazda CX-9 Grand Touring

2007 ENGINE PERFORMANCE On-Board Diagnostic (MZI-3.5) - CX-9

	<ul style="list-style-type: none"> <li>• Disconnect PCM connector.</li> <li>• Check for poor connection (such as damaged, pulled-out pins, and corrosion).</li> <li>• Are there any malfunction?</li> </ul>	No	Go to the next step.
9	<b>INSPECT CMP SENSOR (RH) CIRCUIT FOR OPEN CIRCUIT</b> <ul style="list-style-type: none"> <li>• Turn the ignition switch off.</li> <li>• Check continuity between the following circuits:                             <ul style="list-style-type: none"> <li>○ CMP sensor (RH) terminal A and PCM terminal 2X</li> <li>○ CMP sensor (RH) terminal B and PCM terminal 2C</li> </ul> </li> <li>• Is there continuity?</li> </ul>	Yes	Go to the next step.
		No	Repair or replace suspected part, then go to Step 11.
10	<b>INSPECT CMP SENSOR (RH)</b> <ul style="list-style-type: none"> <li>• Inspect CMP sensor (RH).</li> </ul> <p>(see <b><u>CAMSHAFT POSITION (CMP) SENSOR INSPECTION [MZI-3.5].</u></b> )</p> <ul style="list-style-type: none"> <li>• Is there any malfunction?</li> </ul>	Yes	Replace CMP sensor (RH), then go to the next step. (see <b><u>CAMSHAFT POSITION (CMP) SENSOR REMOVAL/INSTALLATION [MZI-3.5].</u></b> )
		No	Go to the next step.
11	<b>VERIFY TROUBLESHOOTING OF DTC P0344 COMPLETED</b> <ul style="list-style-type: none"> <li>• Verify that all disconnected connectors reconnected.</li> <li>• Turn ignition switch to the ON position (Engine off).</li> <li>• Clear the DTC from the PCM memory using the M-MDS.</li> <li>• Start the engine.</li> <li>• Access the MAF PID using the M-MDS.</li> <li>• Is same DTC present?</li> </ul>	Yes	Replace the PCM, then go to the next step. (see <b><u>PCM REMOVAL/INSTALLATION [MZI-3.5].</u></b> )
		No	Go to the next step.
12	<b>VERIFY AFTER REPAIR PROCEDURE</b> <ul style="list-style-type: none"> <li>• Perform the "AFTER REPAIR PROCEDURE".</li> </ul>	Yes	Go to the applicable DTC inspection. (See <b><u>DTC TABLE [MZI-3.5].</u></b> )

## 2007 Mazda CX-9 Grand Touring

2007 ENGINE PERFORMANCE On-Board Diagnostic (MZI-3.5) - CX-9

(See **AFTER REPAIR  
PROCEDURE [MZI-3.5].**)

No Troubleshooting completed.

- Are any DTC present?

### DTC P0345 [MZI-3.5]

#### DTC P0345 (MZI-3.5) DETECTION CONDITION AND POSSIBLE CAUSES

DTC P0345	CMP sensor (LH) circuit
<b>DETECTION CONDITION</b>	<ul style="list-style-type: none"><li>• The test fails when the PCM can no longer detect the signal from the CMP sensor (LH).</li></ul>
<b>POSSIBLE CAUSE</b>	<ul style="list-style-type: none"><li>• Connector or terminal malfunction</li><li>• CMP sensor (LH) malfunction</li><li>• Short to ground circuit between CMP sensor (LH) terminal A and PCM terminal 2</li><li>• Short to power supply between CMP sensor (LH) terminal A and PCM terminal 2</li><li>• Open circuit between CMP sensor (LH) terminal A and PCM terminal 2AB</li><li>• Open circuit between CMP sensor (LH) terminal B and PCM terminal 2C</li><li>• PCM malfunction</li></ul>

## 2007 Mazda CX-9 Grand Touring

2007 ENGINE PERFORMANCE On-Board Diagnostic (MZI-3.5) - CX-9

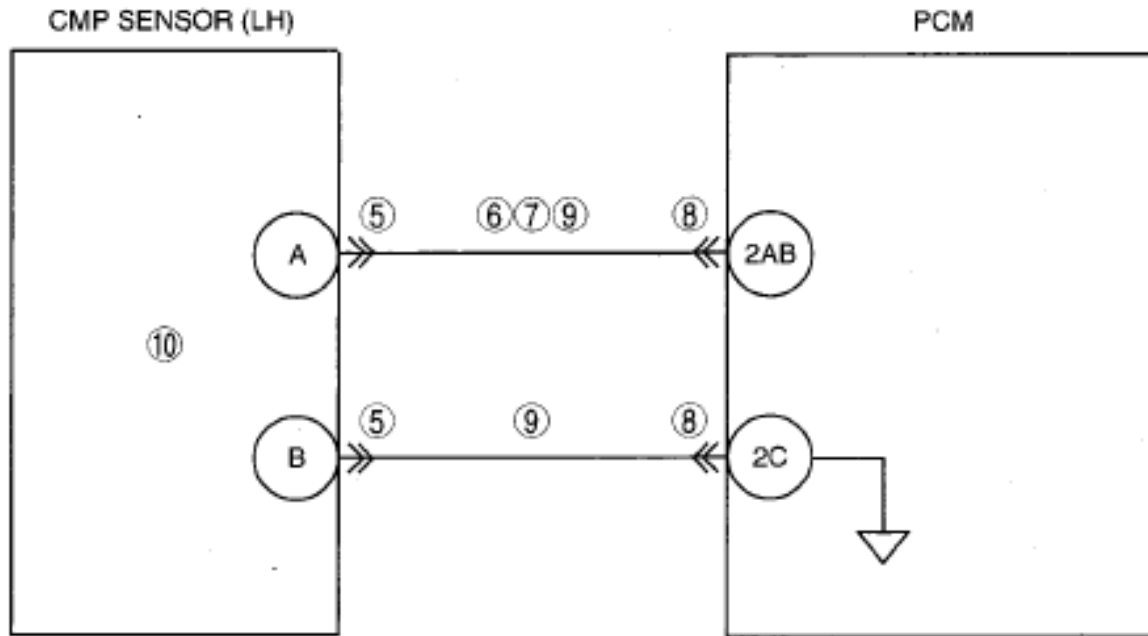

PCM  
WIRING HARNESS-SIDE CONNECTOR

CMP SENSOR (LH)  
WIRING HARNESS-SIDE CONNECTOR

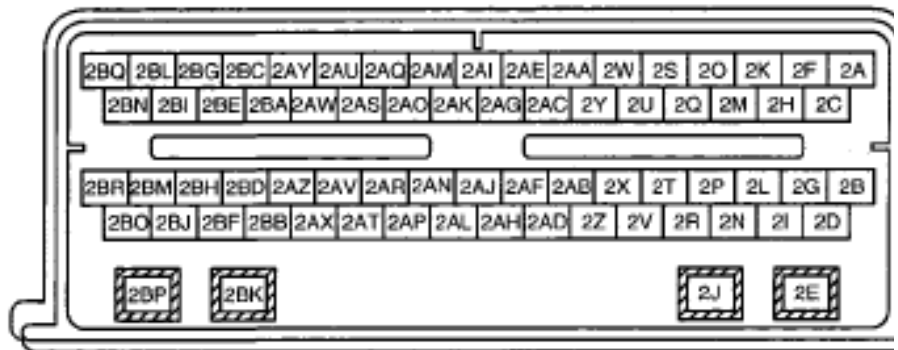
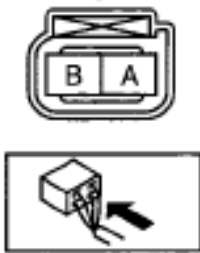

### DIAGNOSTIC PROCEDURE

#### DTC P0345 (MZI-3.5) DIAGNOSTIC PROCEDURE

STEP	INSPECTION	ACTION	
1	<b>VERIFY FREEZE FRAME DATA HAS BEEN RECORDED</b>  • Has FREEZE FRAME DATA	Yes	Go to the next step.
		No	Record FREEZE FRAME DATA on the repair order, then go to the next step.

## 2007 Mazda CX-9 Grand Touring

2007 ENGINE PERFORMANCE On-Board Diagnostic (MZI-3.5) - CX-9

	been recorded?		
2	<b>VERIFY RELATED REPAIR INFORMATION AVAILABILITY</b> <ul style="list-style-type: none"> <li>• Verify related Service Bulletins and/or on-line repair information availability.</li> <li>• Is any related Service Bulletins available?</li> </ul>	Yes	Perform repair or diagnosis according to the available Service Bulletins. <ul style="list-style-type: none"> <li>• If the vehicle is not repaired, go to the next step.</li> </ul>
		No	Go to the next step.
3	<b>CLEAR AND ATTEMPT TO RETRIEVE THE DTC</b> <p><b>NOTE:</b></p> <ul style="list-style-type: none"> <li>• If DTCs <b>P0340, P0344, P0345 or P0349</b> are present, <b>ignition, alternator noise, radio frequency interference and CKP concerns should be considered.</b></li> <li>• Clear the DTC from the PCM memory using the M-MDS.</li> <li>• Turn the ignition switch to the ON position (Engine running).</li> <li>• Increase engine speed to <b>more than 1,500 rpm for 10s.</b> Repeat this <b>3 times.</b></li> <li>• Retrieve the continuous memory DTCs.</li> <li>• The same DTC present?</li> </ul>	Yes	Go to the next step.
		No	Perform the "INTERMITTENT CONCERN TROUBLESHOOTING". Then go to Step 11.
4	<b>CHECK THE GENERATOR FOR EXCESSIVE ELECTRICAL NOISE</b> <p><b>NOTE:</b></p> <ul style="list-style-type: none"> <li>• If the generator/regulator is electrically noisy, the noise decreases when the terminal B is disconnected.</li> <li>• Turn the ignition switch to the ON position (Engine running).</li> <li>• Monitor the generator for an audible electric noise.</li> <li>• Turn the ignition switch off.</li> <li>• Generator/regulator terminal B</li> </ul>	Yes	Go to the next step.
		No	<ul style="list-style-type: none"> <li>• Inspect the charging system, then go to Step 11.                             <ul style="list-style-type: none"> <li>○ Drive belt damaged and misinstallation</li> <li>○ Generator pulley or generator misinstallation</li> </ul> </li> </ul>

## 2007 Mazda CX-9 Grand Touring

2007 ENGINE PERFORMANCE On-Board Diagnostic (MZI-3.5) - CX-9

	<p>disconnected.</p> <ul style="list-style-type: none"> <li>• Turn the ignition switch to the ON position (Engine running).</li> <li>• With the engine running, determine if the generator is still noisy.</li> <li>• Does the noise remain constant when the terminal B is disconnected?</li> </ul>		
5	<p><b>INSPECT CMP SENSOR (LH) CONNECTOR FOR POOR CONNECTION</b></p> <ul style="list-style-type: none"> <li>• Turn the ignition switch off.</li> <li>• Disconnect the CMP sensor (LH) connector.</li> <li>• Inspect for poor connection (such as damaged/pulled-out pins, corrosion).</li> <li>• Are there any malfunction?</li> </ul>	Yes	Repair or replace suspected part, then go to Step 11.
		No	Go to the next step.
6	<p><b>INSPECT CMP SENSOR SIGNAL CIRCUIT FOR SHORT TO POWER SUPPLY</b></p> <ul style="list-style-type: none"> <li>• Turn the ignition switch to the ON position (Engine off).</li> <li>• Measure voltage between CMP sensor (LH) terminal A (wiring harness-side) and body ground.</li> <li>• Is the voltage <b>B+</b> ?</li> </ul>	Yes	Repair or replace suspected part, then go to Step 11.
		No	Go to the next step.
7	<p><b>INSPECT CMP SENSOR (LH) SIGNAL CIRCUIT FOR SHORT TO GROUND</b></p> <ul style="list-style-type: none"> <li>• Turn the ignition switch off.</li> <li>• Check continuity between CMP sensor (LH) terminal A and body ground.</li> <li>• Is there continuity?</li> </ul>	Yes	Repair or replace suspected part, then go to Step 11.
		No	Go to the next step.
8	<p><b>INSPECT PCM CONNECTOR FOR POOR CONNECTION</b></p> <ul style="list-style-type: none"> <li>• Turn the ignition switch off.</li> </ul>	Yes	Repair or replace suspected part, then go to Step 11.

## 2007 Mazda CX-9 Grand Touring

2007 ENGINE PERFORMANCE On-Board Diagnostic (MZI-3.5) - CX-9

	<ul style="list-style-type: none"> <li>• Disconnect PCM connector.</li> <li>• Check for poor connection (such as damaged, pulled-out pins, and corrosion).</li> <li>• Are there any malfunction?</li> </ul>	No	Go to the next step.
9	<b>INSPECT CMP SENSOR (LH) CIRCUIT FOR OPEN CIRCUIT</b> <ul style="list-style-type: none"> <li>• Turn the ignition switch off.</li> <li>• Check continuity between the following circuits:                             <ul style="list-style-type: none"> <li>○ CMP sensor (LH) terminal A and PCM terminal 2AB</li> <li>○ CMP sensor (LH) terminal B and PCM terminal 2C</li> </ul> </li> <li>• Is there continuity?</li> </ul>	Yes	Go to the next step.
		No	Repair or replace suspected part, then go to Step 11.
10	<b>INSPECT CMP SENSOR (LH)</b> <ul style="list-style-type: none"> <li>• Inspect CMP sensor (LH).</li> </ul> <p>(see <b><u>CAMSHAFT POSITION (CMP) SENSOR INSPECTION [MZI-3.5].</u></b>)</p> <ul style="list-style-type: none"> <li>• Is there any malfunction?</li> </ul>	Yes	Replace CMP sensor (LH), then go to the next step. (see <b><u>CAMSHAFT POSITION (CMP) SENSOR REMOVAL/INSTALLATION [MZI-3.5].</u></b> )
		No	Go to the next step.
11	<b>VERIFY TROUBLESHOOTING OF DTC P0345 COMPLETED</b> <ul style="list-style-type: none"> <li>• Verify that all disconnected connectors reconnected.</li> <li>• Turn ignition switch to the ON position (Engine off).</li> <li>• Clear the DTC from the PCM memory using the M-MDS.</li> <li>• Start the engine.</li> <li>• Access the MAF PID using the M-MDS.</li> <li>• Is same DTC present?</li> </ul>	Yes	Replace the PCM, then go to the next step. (see <b><u>PCM REMOVAL/INSTALLATION [MZI-3.5].</u></b> )
		No	Go to the next step.
12	<b>VERIFY AFTER REPAIR PROCEDURE</b> <ul style="list-style-type: none"> <li>• Perform the "AFTER REPAIR PROCEDURE".</li> </ul>	Yes	Go to the applicable DTC inspection. (See <b><u>DTC TABLE [MZI-3.5].</u></b> )



## 2007 Mazda CX-9 Grand Touring

2007 ENGINE PERFORMANCE On-Board Diagnostic (MZI-3.5) - CX-9

<p>(See <b>AFTER REPAIR PROCEDURE [MZI-3.5].</b>)</p> <ul style="list-style-type: none"><li>• Are any DTC present?</li></ul>	No	Troubleshooting completed.
--	----	----------------------------

### DTC P0349 [MZI-3.5]

#### DTC P0349 (MZI-3.5) DETECTION CONDITION AND POSSIBLE CAUSES

<b>DTC P0349</b>	<b>CMP sensor (LH) circuit intermittent</b>
<b>DETECTION CONDITION</b>	<ul style="list-style-type: none"><li>• The test fails when the PCM detects an intermittent signal from the CMP sensor (LH).</li></ul>
<b>POSSIBLE CAUSE</b>	<ul style="list-style-type: none"><li>• Connector or terminal malfunction</li><li>• CMP sensor (LH) malfunction</li><li>• Sensor shielding malfunction</li><li>• Short to ground circuit between CMP sensor (LH) terminal A and PCM terminal 2</li><li>• Short to power supply between CMP sensor (LH) terminal A and PCM terminal 2</li><li>• Open circuit between CMP sensor (LH) terminal A and PCM terminal 2AB</li><li>• Open circuit between CMP sensor (LH) terminal B and PCM terminal 2C</li></ul>

## 2007 Mazda CX-9 Grand Touring

2007 ENGINE PERFORMANCE On-Board Diagnostic (MZI-3.5) - CX-9

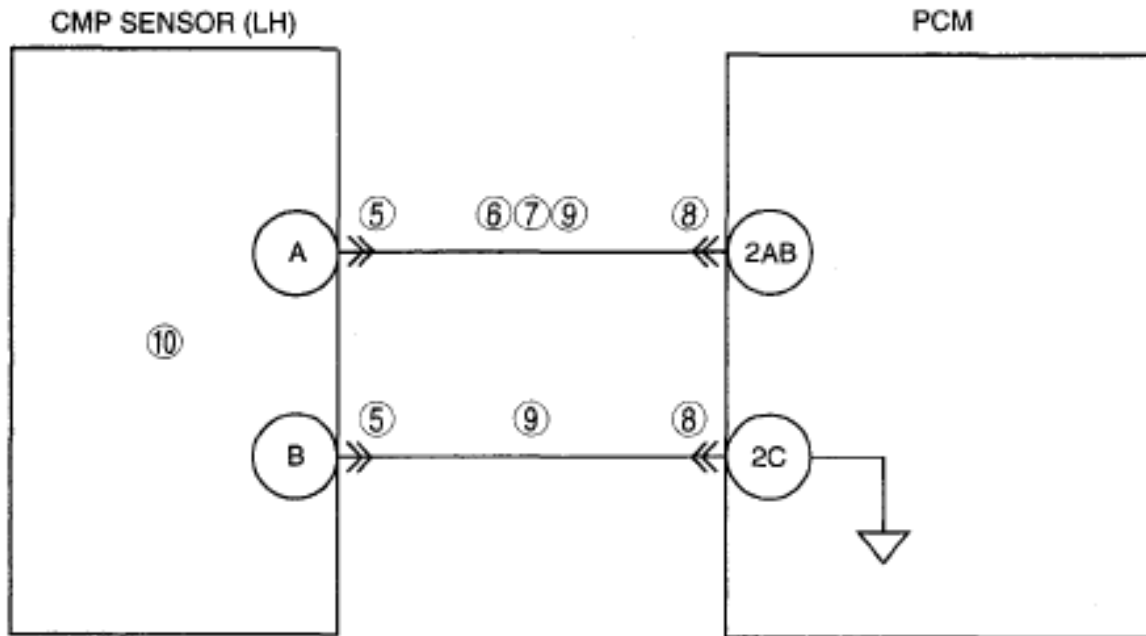

PCM  
WIRING HARNESS-SIDE CONNECTOR

CMP SENSOR (LH)  
WIRING HARNESS-SIDE CONNECTOR

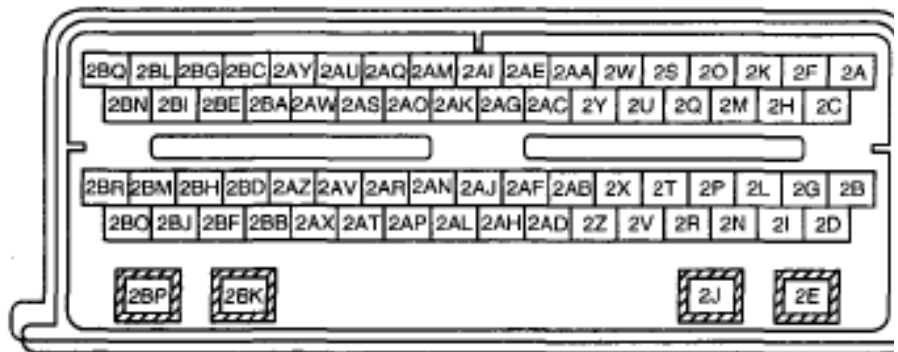
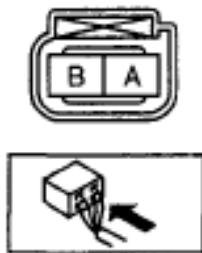

### DIAGNOSTIC PROCEDURE

#### DTC P0349 (MZI-3.5) DIAGNOSTIC PROCEDURE

STEP	INSPECTION		ACTION
1	<b>VERIFY FREEZE FRAME DATA HAS BEEN RECORDED</b>	Yes	Go to the next step.
		No	Record FREEZE FRAME DATA on the repair order, then go to the next step.
	<ul style="list-style-type: none"> <li>Has FREEZE FRAME DATA</li> </ul>		

## 2007 Mazda CX-9 Grand Touring

2007 ENGINE PERFORMANCE On-Board Diagnostic (MZI-3.5) - CX-9

	been recorded?		
2	<b>VERIFY RELATED REPAIR INFORMATION AVAILABILITY</b> <ul style="list-style-type: none"> <li>• Verify related Service Bulletins and/or on-line repair information availability.</li> <li>• Is any related Service Bulletins available?</li> </ul>	Yes	Perform repair or diagnosis according to the available Service Bulletins. <ul style="list-style-type: none"> <li>• If the vehicle is not repaired, go to the next step.</li> </ul>
		No	Go to the next step.
3	<b>CLEAR AND ATTEMPT TO RETRIEVE THE DTC</b> <p><b>NOTE:</b></p> <ul style="list-style-type: none"> <li>• If DTCs P0340, P0344, P0345 or P0349 are present, ignition, alternator noise, radio frequency interference and CKP concerns should be considered.</li> <li>• Clear the DTC from the PCM memory using the M-MDS.</li> <li>• Turn the ignition switch to the ON position (Engine running).</li> <li>• Increase engine speed to <b>more than 1,500 rpm</b> for <b>10s</b>. Repeat this <b>3 times</b>.</li> <li>• Retrieve the continuous memory DTCs.</li> <li>• The same DTC present?</li> </ul>	Yes	Go to the next step.
		No	Perform the "INTERMITTENT CONCERN TROUBLESHOOTING". Then go to Step 11.
4	<b>CHECK THE GENERATOR FOR EXCESSIVE ELECTRICAL NOISE</b> <p><b>NOTE:</b></p> <ul style="list-style-type: none"> <li>• If the generator/regulator is electrically noisy, the noise decreases when the terminal B is disconnected.</li> <li>• Turn the ignition switch to the ON position (Engine running).</li> <li>• Monitor the generator for an audible electric noise.</li> <li>• Turn the ignition switch off.</li> <li>• Generator/regulator terminal B</li> </ul>	Yes	Go to the next step.
		No	<ul style="list-style-type: none"> <li>• Inspect the charging system, then go to Step 11.                             <ul style="list-style-type: none"> <li>○ Drive belt damaged and misinstallation</li> <li>○ Generator pulley or generator misinstallation</li> </ul> </li> </ul>

## 2007 Mazda CX-9 Grand Touring

2007 ENGINE PERFORMANCE On-Board Diagnostic (MZI-3.5) - CX-9

	<p>disconnected.</p> <ul style="list-style-type: none"> <li>• Turn the ignition switch to the ON position (Engine running).</li> <li>• With the engine running, determine if the generator is still noisy.</li> <li>• Does the noise remain constant when the terminal B is disconnected?</li> </ul>		
5	<p><b>INSPECT CMP SENSOR (LH) CONNECTOR FOR POOR CONNECTION</b></p> <ul style="list-style-type: none"> <li>• Turn the ignition switch off.</li> <li>• Disconnect the CMP sensor (LH) connector.</li> <li>• Inspect for poor connection (such as damaged/pulled-out pins, corrosion).</li> <li>• Are there any malfunction?</li> </ul>	Yes	Repair or replace suspected part, then go to Step 11.
		No	Go to the next step.
6	<p><b>INSPECT CMP SENSOR SIGNAL CIRCUIT FOR SHORT TO POWER SUPPLY</b></p> <ul style="list-style-type: none"> <li>• Turn the ignition switch to the ON position (Engine off).</li> <li>• Measure voltage between CMP sensor (LH) terminal A (wiring harness-side) and body ground.</li> <li>• Is the voltage <b>B+</b> ?</li> </ul>	Yes	Repair or replace suspected part, then go to Step 11.
		No	Go to the next step.
7	<p><b>INSPECT CMP SENSOR (LH) SIGNAL CIRCUIT FOR SHORT TO GROUND</b></p> <ul style="list-style-type: none"> <li>• Turn the ignition switch off.</li> <li>• Check continuity between CMP sensor (LH) terminal A and body ground.</li> <li>• Is there continuity?</li> </ul>	Yes	Repair or replace suspected part, then go to Step 11.
		No	Go to the next step.
8	<p><b>INSPECT PCM CONNECTOR FOR POOR CONNECTION</b></p> <ul style="list-style-type: none"> <li>• Turn the ignition switch off.</li> </ul>	Yes	Repair or replace suspected part, then go to Step 11.

## 2007 Mazda CX-9 Grand Touring

2007 ENGINE PERFORMANCE On-Board Diagnostic (MZI-3.5) - CX-9

	<ul style="list-style-type: none"> <li>• Disconnect PCM connector.</li> <li>• Check for poor connection (such as damaged, pulled-out pins, and corrosion).</li> <li>• Are there any malfunction?</li> </ul>	No	Go to the next step.
9	<b>INSPECT CMP SENSOR (LH) CIRCUIT FOR OPEN CIRCUIT</b> <ul style="list-style-type: none"> <li>• Turn the ignition switch off.</li> <li>• Check continuity between the following circuits:                             <ul style="list-style-type: none"> <li>○ CMP sensor (LH) terminal A and PCM terminal 2AB</li> <li>○ CMP sensor (LH) terminal B and PCM terminal 2C</li> </ul> </li> <li>• Is there continuity?</li> </ul>	Yes	Go to the next step.
		No	Repair or replace suspected part, then go to Step 11.
10	<b>INSPECT CMP SENSOR (LH)</b> <ul style="list-style-type: none"> <li>• Inspect CMP sensor (LH).</li> </ul> <p>(see <b><u>CAMSHAFT POSITION (CMP) SENSOR INSPECTION [MZI-3.5].</u></b>)</p> <ul style="list-style-type: none"> <li>• Is there any malfunction?</li> </ul>	Yes	Replace CMP sensor (LH), then go to the next step. (see <b><u>CAMSHAFT POSITION (CMP) SENSOR REMOVAL/INSTALLATION [MZI-3.5].</u></b> )
		No	Go to the next step.
11	<b>VERIFY TROUBLESHOOTING OF DTC P0349 COMPLETED</b> <ul style="list-style-type: none"> <li>• Verify that all disconnected connectors reconnected.</li> <li>• Turn ignition switch to the ON position (Engine off).</li> <li>• Clear the DTC from the PCM memory using the M-MDS.</li> <li>• Start the engine.</li> <li>• Access the MAF PID using the M-MDS.</li> <li>• Is same DTC present?</li> </ul>	Yes	Replace the PCM, then go to the next step. (see <b><u>PCM REMOVAL/INSTALLATION [MZI-3.5].</u></b> )
		No	Go to the next step.
12	<b>VERIFY AFTER REPAIR PROCEDURE</b> <ul style="list-style-type: none"> <li>• Perform the "AFTER REPAIR PROCEDURE".</li> </ul>	Yes	Go to the applicable DTC inspection. (See <b><u>DTC TABLE [MZI-3.5].</u></b> )

## 2007 Mazda CX-9 Grand Touring

2007 ENGINE PERFORMANCE On-Board Diagnostic (MZI-3.5) - CX-9

<p>(See <b><u>AFTER REPAIR PROCEDURE [MZI-3.5].</u></b>)</p> <ul style="list-style-type: none"> <li>• Are any DTC present?</li> </ul>	No	Troubleshooting completed.
---	----	----------------------------

### DTC P0351, 0352, 0353, 0354, 0355, 0356 [MZI-3.5]

#### DTC P0351, 0352, 0353, 0354, 0355, 0356 (MZI-3.5) DETECTION CONDITION AND POSSIBLE CAUSES

<b>DTC P0351</b>	<b>P0351: Ignition coil No.1 primary/secondary circuit</b>
<b>DTC P0352</b>	<b>P0352: Ignition coil No.2 primary/secondary circuit</b>
<b>DTC P0353</b>	<b>P0353: Ignition coil No.3 primary/secondary circuit</b>
<b>DTC P0354</b>	<b>P0354: Ignition coil No.4 primary/secondary circuit</b>
<b>DTC P0355</b>	<b>P0355: Ignition coil No.5 primary/secondary circuit</b>
<b>DTC P0356</b>	<b>P0356: Ignition coil No.6 primary/secondary circuit</b>
<b>DETECTION CONDITION</b>	<ul style="list-style-type: none"> <li>• Each ignition primary circuit is continuously monitored. The test fails when the P does not receive a valid ignition diagnostic monitor pulse signal from the ignition module (integrated in the PCM).</li> </ul>
<b>POSSIBLE CAUSE</b>	<ul style="list-style-type: none"> <li>• Connector or terminal malfunction</li> <li>• Open circuit between ignition coil No.1 terminal C and PCM terminal 2A</li> <li>• Open circuit between ignition coil No.2 terminal C and PCM terminal 2F</li> <li>• Open circuit between ignition coil No.3 terminal C and PCM terminal 2K</li> <li>• Open circuit between ignition coil No.4 terminal C and PCM terminal 2W</li> <li>• Open circuit between ignition coil No.5 terminal C and PCM terminal 2AA</li> <li>• Open circuit between ignition coil No.6 terminal C and PCM terminal 2AE</li> <li>• Short to power supply between ignition coil No.1 terminal C and PCM terminal 2</li> <li>• Short to power supply between ignition coil No.2 terminal C and PCM terminal 2</li> <li>• Short to power supply between ignition coil No.3 terminal C and PCM terminal 2</li> <li>• Short to power supply between ignition coil No.4 terminal C and PCM terminal 2</li> <li>• Short to power supply between ignition coil No.5 terminal C and PCM terminal 2</li> <li>• Short to power supply between ignition coil No.6 terminal C and PCM terminal 2</li> <li>• Short to ground circuit between ignition coil No.1 terminal C and PCM terminal 2</li> <li>• Short to ground circuit between ignition coil No.2 terminal C and PCM terminal 2</li> <li>• Short to ground circuit between ignition coil No.3 terminal C and PCM terminal 2</li> <li>• Short to ground circuit between ignition coil No.4 terminal C and PCM terminal 2</li> <li>• Short to ground circuit between ignition coil No.5 terminal C and PCM terminal 2</li> <li>• Short to ground circuit between ignition coil No.6 terminal C and PCM terminal 2</li> <li>• Open circuit between ignition coil terminal A and main relay No.2 terminal D</li> <li>• Ignition coil malfunction</li> </ul>

# 2007 Mazda CX-9 Grand Touring

2007 ENGINE PERFORMANCE On-Board Diagnostic (MZI-3.5) - CX-9

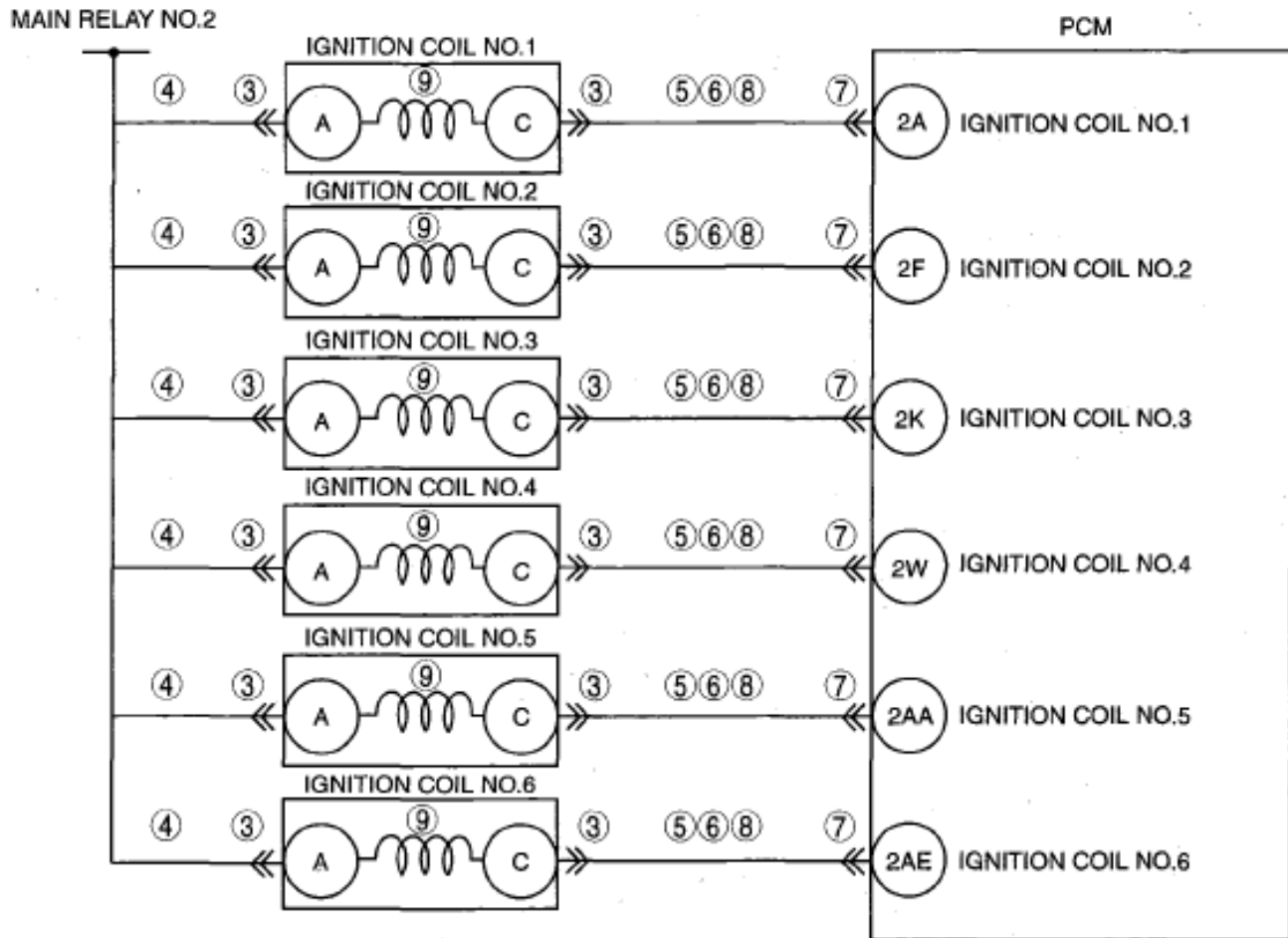

IGNITION COIL NO.1—NO.6  
MAIN RELAY NO.2 WIRING HARNESS-SIDE CONNECTOR

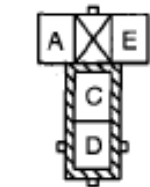

PCM  
WIRING HARNESS-SIDE CONNECTOR

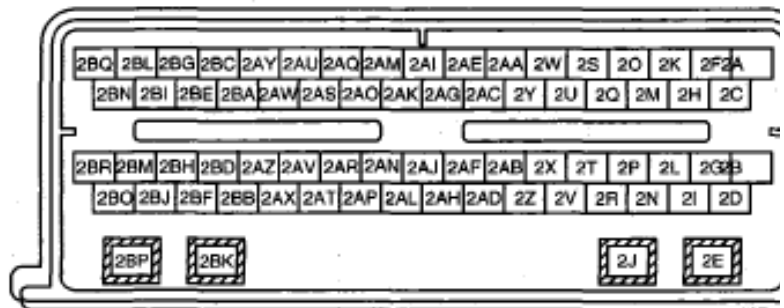

## DIAGNOSTIC PROCEDURE

DTC P0351, 0352, 0353, 0354, 0355, 0356 (MZI-3.5) DIAGNOSTIC PROCEDURE

## 2007 Mazda CX-9 Grand Touring

2007 ENGINE PERFORMANCE On-Board Diagnostic (MZI-3.5) - CX-9

STEP	INSPECTION	ACTION	
1	<b>VERIFY FREEZE FRAME DATA HAS BEEN RECORDED</b> <ul style="list-style-type: none"> <li>• Has FREEZE FRAME DATA been recorded?</li> </ul>	Yes	Go to the next step.
		No	Record FREEZE FRAME DATA on the repair order, then go to the next step.
2	<b>VERIFY RELATED REPAIR INFORMATION AVAILABILITY</b> <ul style="list-style-type: none"> <li>• Verify related Service Bulletins and/or on-line repair information availability.</li> <li>• Is any related Service Bulletins available?</li> </ul>	Yes	Perform repair or diagnosis according to the available Service Bulletins. <ul style="list-style-type: none"> <li>• If the vehicle is not repaired, go to the next step.</li> </ul>
		No	Go to the next step.
3	<b>INSPECT IGNITION COIL CONNECTOR FOR POOR CONNECTION</b> <ul style="list-style-type: none"> <li>• Turn the ignition switch off.</li> <li>• Disconnect the ignition coil connector.</li> <li>• Inspect for poor connection (such as damaged/pulled-out pins, corrosion).</li> <li>• Are there any malfunction?</li> </ul>	Yes	Repair or replace suspected part, then go to Step 10.
		No	Go to the next step.
4	<b>INSPECT IGNITION COIL POWER SUPPLY CIRCUIT FOR OPEN CIRCUIT</b> <ul style="list-style-type: none"> <li>• Disconnect the ignition coil connector.</li> <li>• Turn the ignition switch to the ON position (Engine off).</li> <li>• Measure the voltage between ignition coil terminal A (wiring harness-side) and body ground.</li> <li>• Is the voltage <b>B+</b> ?</li> </ul>	Yes	Go to the next step.
		No	Repair or replace suspected part, then go to Step 10.
5	<b>INSPECT IGNITION COIL SIGNAL CIRCUIT FOR SHORT TO POWER SUPPLY</b> <ul style="list-style-type: none"> <li>• Turn the ignition switch to the ON position (Engine off).</li> <li>• Measure the voltage between</li> </ul>	Yes	Repair or replace suspected part, then go to Step 10.



## 2007 Mazda CX-9 Grand Touring

2007 ENGINE PERFORMANCE On-Board Diagnostic (MZI-3.5) - CX-9

	<p>ignition coil terminal C (wiring harness-side) and body ground.</p> <ul style="list-style-type: none"> <li>• Is the voltage <b>B+</b> ?</li> </ul>	No	Go to the next step.
6	<p><b>INSPECT IGNITION COIL SIGNAL CIRCUIT FOR SHORT TO GROUND</b></p> <ul style="list-style-type: none"> <li>• Turn the ignition switch to the ON position (Engine off).</li> <li>• Inspect continuity between ignition coil terminal C (wiring harness-side) and body ground.</li> <li>• Is there continuity?</li> </ul>	Yes	Repair or replace suspected part, then go to Step 10.
		No	Go to the next step.
7	<p><b>INSPECT PCM CONNECTOR FOR POOR CONNECTION</b></p> <ul style="list-style-type: none"> <li>• Turn the ignition switch off.</li> <li>• Disconnect PCM connector.</li> <li>• Inspect for poor connection (such as damaged/pulled-out pins, corrosion).</li> <li>• Is there any malfunction?</li> </ul>	Yes	Repair or replace suspected part, then go to Step 10.
		No	Go to the next step.
8	<p><b>INSPECT IGNITION COIL SIGNAL CIRCUIT FOR OPEN CIRCUIT</b></p> <ul style="list-style-type: none"> <li>• Inspect continuity between the following circuits:                             <ul style="list-style-type: none"> <li>○ Ignition coil No.1 terminal C (wiring harness-side) and PCM terminal 2A (wiring harness-side)</li> <li>○ Ignition coil No.2 terminal C (wiring harness-side) and PCM terminal 2F (wiring harness-side)</li> <li>○ Ignition coil No.3 terminal C (wiring harness-side) and PCM terminal 2K (wiring harness-side)</li> <li>○ Ignition coil No.4 terminal C (wiring harness-side) and PCM terminal 2W (wiring harness-side)</li> <li>○ Ignition coil No.5 terminal</li> </ul> </li> </ul>	Yes	Go to the next step.
		No	Repair or replace suspected part, then go to Step 10.

## 2007 Mazda CX-9 Grand Touring

2007 ENGINE PERFORMANCE On-Board Diagnostic (MZI-3.5) - CX-9

	<p>C (wiring harness-side) and PCM terminal 2AA (wiring harness-side)</p> <ul style="list-style-type: none"> <li>○ Ignition coil No.6 terminal C (wiring harness-side) and PCM terminal 2AE (wiring harness-side)</li> </ul> <ul style="list-style-type: none"> <li>● Are there continuity?</li> </ul>		
9	<p><b>INSPECT IGNITION COIL</b></p> <ul style="list-style-type: none"> <li>● Inspect ignition coil.</li> </ul> <p>(see <b><u>IGNITION COIL INSPECTION [MZI-3.5]</u></b> .)</p> <ul style="list-style-type: none"> <li>● Are there ignition coil normal?</li> </ul>	Yes	Go to the next step.
		No	Replace the ignition coil, then go to the next step.
10	<p><b>VERIFY TROUBLESHOOTING OF DTC P0351, P0352, P0353, P0354, P0355 and P0356 COMPLETED</b></p> <ul style="list-style-type: none"> <li>● Verify that all disconnected connectors reconnected.</li> <li>● Clear the DTC from the PCM memory using the M-MDS.</li> <li>● Perform the "KOEO or KOER self-test" using the M-MDS.</li> </ul> <p>(See <b><u>KOEO/KOER SELF TEST [MZI-3.5]</u></b>.)</p> <ul style="list-style-type: none"> <li>● Is the PENDING CODE for the DTC present?</li> </ul>	Yes	Replace the PCM, then go to the next step. (see <b><u>PCM REMOVAL/INSTALLATION [MZI-3.5]</u></b> .)
		No	Go to the next step.
11	<p><b>VERIFY AFTER REPAIR PROCEDURE</b></p> <ul style="list-style-type: none"> <li>● Perform "AFTER REPAIR PROCEDURE".</li> </ul> <p>(See <b><u>AFTER REPAIR PROCEDURE [MZI-3.5]</u></b>.)</p> <ul style="list-style-type: none"> <li>● Are any DTCs present?</li> </ul>	Yes	Go to the applicable DTC inspection. (See <b><u>DTC TABLE [MZI-3.5]</u></b> .)
		No	Troubleshooting completed.

**DTC P0420, P0430 [MZI-3.5]**

## 2007 Mazda CX-9 Grand Touring

2007 ENGINE PERFORMANCE On-Board Diagnostic (MZI-3.5) - CX-9

### DTC P0420, P0430 (MZI-3.5) DETECTION CONDITION AND POSSIBLE CAUSES

<b>DTC P0420</b>	<b>P0420: Catalyst system efficiency below threshold (RH)</b>
<b>DTC P0430</b>	<b>P0430: Catalyst system efficiency below threshold (LH)</b>
<b>DETECTION CONDITION</b>	<ul style="list-style-type: none"> <li>• P0420 indicates right bank catalyst system efficiency is below the acceptable threshold.</li> <li>• P0430 indicates left bank catalyst system efficiency is below the acceptable threshold.</li> </ul>
<b>POSSIBLE CAUSE</b>	<ul style="list-style-type: none"> <li>• Use of leaded fuel.</li> <li>• Oil contamination</li> <li>• Cylinder misfiring.</li> <li>• Damaged HO2S.</li> <li>• Malfunctioning CHT sensor.</li> <li>• Downstream HO2S wires improperly connected.</li> <li>• Fuel pressure too high.</li> <li>• Damaged exhaust system pipe.</li> <li>• Damaged exhaust manifold.</li> <li>• Damaged muffler/tailpipe ass</li> </ul> <p><b>NOTE:</b></p> <ul style="list-style-type: none"> <li>• Internal deterioration of a catalytic converter is usually caused by abnormal engine operation front of the catalyst. Events that can produce higher than normal temperatures in the catalyst are particularly suspect, such as misfiring. Incorrect HO2S signal input (e.g., rich/lean signal when engine is operating under rich/lean conditions) can cause an abnormal temperature increase in the catalyst. CHT sensor DTCs can indicate that the thermostat is not operating correctly or that the engine coolant level is not filled to specification, producing above normal operating temperatures.</li> </ul>

### DIAGNOSTIC PROCEDURE

#### DTC P0420, P0430 (MZI-3.5) DIAGNOSTIC PROCEDURE

STEP	INSPECTION		ACTION
1	<b>VERIFY FREEZE FRAME DATA HAS BEEN RECORDED</b> <ul style="list-style-type: none"> <li>• Has FREEZE FRAME DATA been recorded?</li> </ul>	Yes	Go to the next step.
		No	Record FREEZE FRAME DATA on the repair order, then go to the next step.
2	<b>VERIFY RELATED REPAIR INFORMATION AVAILABILITY</b> <ul style="list-style-type: none"> <li>• Verify related Service Bulletins</li> </ul>	Yes	Perform repair or diagnosis according to the available Service Bulletins.
			<ul style="list-style-type: none"> <li>• If the vehicle is not repaired, go to</li> </ul>

## 2007 Mazda CX-9 Grand Touring

2007 ENGINE PERFORMANCE On-Board Diagnostic (MZI-3.5) - CX-9

	and/or on-line repair information availability.		the next step.
	<ul style="list-style-type: none"> <li>Is any related Service Bulletins available?</li> </ul>	No	Go to the next step.
3	<b>VERIFY RELATED PENDING CODE OR STORED DTCs</b> <ul style="list-style-type: none"> <li>Turn the ignition switch off then to the ON position (Engine off).</li> <li>Verify related pending code or stored DTCs.</li> <li>Is other DTCs present?</li> </ul>	Yes	Go to the appropriate DTC troubleshooting. (See <b><u>DTC TABLE [MZI-3.5].</u></b> )
		No	Go to the next step.
4	<b>INSPECT GAS LEAKAGE OF EXHAUST SYSTEM</b> <ul style="list-style-type: none"> <li>Visually inspect for exhaust gas leakage in exhaust system.</li> <li>Are there gas leakage?</li> </ul>	Yes	Repair or replace malfunctioning exhaust parts, then go to Step 7.
		No	Go to the next step.
5	<b>INSPECT INSTALLATION OF FRONT AND REAR HO2S</b> <ul style="list-style-type: none"> <li>Inspect for looseness of front and rear HO2Ss.</li> <li>Are they it normal?</li> </ul>	Yes	Go to the next step.
		No	Retighten sensor, then go to Step 7.
6	<b>INSPECT TWC</b> <ul style="list-style-type: none"> <li>Clear the DTC using the M-MDS.</li> <li>Cycle the ignition switch off then back to the ON position.</li> <li>Inspect the TWC.</li> <li>Is it normal?</li> </ul>	Yes	Go to the next step.
		No	Replace the TWC, then go to the next step.
7	<b>VERIFY TROUBLESHOOTING OF DTC P0420, P0430 HAS BEEN COMPLETED</b> <ul style="list-style-type: none"> <li>Verify that all disconnected connectors are reconnected.</li> <li>Turn the ignition switch to the ON position (Engine off).</li> <li>Clear the DTC from the PCM memory using the M-MDS.</li> <li>Start the engine and run it at idle.</li> <li>Retrieve DTCs using the M-MDS.</li> </ul>	Yes	Replace the PCM, then go to the next step. (see <b><u>PCM REMOVAL/INSTALLATION [MZI-3.5]</u></b> .)
		No	Go to the next step.

## 2007 Mazda CX-9 Grand Touring

2007 ENGINE PERFORMANCE On-Board Diagnostic (MZI-3.5) - CX-9

	<ul style="list-style-type: none"> <li>Is the PENDING CODE for this DTC present?</li> </ul>		
8	<b>VERIFY AFTER REPAIR PROCEDURE</b> <ul style="list-style-type: none"> <li>Perform the "AFTER REPAIR PROCEDURE".</li> </ul> <p>(See <b><u>AFTER REPAIR PROCEDURE [MZI-3.5].</u></b>)</p> <ul style="list-style-type: none"> <li>Are any DTC present?</li> </ul>	Yes	Go to the applicable DTC inspection. (See <b><u>DTC TABLE [MZI-3.5].</u></b> )
		No	Troubleshooting completed.

### DTC P0442, P0456 [MZI-3.5]

#### DTC P0442, P0456 (MZI-3.5) DETECTION CONDITION AND POSSIBLE CAUSES

<b>DTC P0442</b>	<b>P0442: Evaporative emission system leak detected (small leak)</b>
<b>DTC P0456</b>	<b>P0456: Evaporative emission system leak detected (very small leak)</b>
<b>DETECTION CONDITION</b>	<ul style="list-style-type: none"> <li>P0442 indicates that a leak has been detected as small as 1 mm (0.04in) in the EVAP vapor management valve solenoid system when there is less than 0.625 kPa (PID FTP_H2O displays "2.5") bleed-up over 15 s at 75% fuel fill. Bleed-up and evaluation time vary as a function of fuel fill level. The vapor generation limit is more than 0.625 kPa (PID FTP_H2O displays "2.5") over 120 s.</li> <li>P0456 indicates that a fuel vapor leak from an opening as small as 0.508 mm (0.020 in) has been detected by the EVAP running loss monitor test.</li> </ul>
<b>POSSIBLE CAUSE</b>	<ul style="list-style-type: none"> <li>After-market EVAP hardware (such as fuel-filler cap) nonconforming to required specifications.</li> <li>Small holes or cuts in fuel vapor hoses/tubes (P0442, P0456).</li> <li>CV solenoid stays partially open on closed command.</li> <li>Damaged, cross-threaded or loosely installed fuel-filler cap.</li> <li>EVAP system component seals leaking.</li> </ul>

### DIAGNOSTIC PROCEDURE

#### DTC P0442, P0456 (MZI-3.5) DIAGNOSTIC PROCEDURE

STEP	INSPECTION		ACTION
1	<b>VERIFY FREEZE FRAME DATA HAS BEEN RECORDED</b> <ul style="list-style-type: none"> <li>Has FREEZE FRAME DATA been recorded?</li> </ul>	Yes	Go to the next step.
		No	Record FREEZE FRAME DATA on the repair order, then go to the next step.
2	<b>VERIFY RELATED REPAIR</b>	Yes	Perform repair or diagnosis according to

## 2007 Mazda CX-9 Grand Touring

2007 ENGINE PERFORMANCE On-Board Diagnostic (MZI-3.5) - CX-9

	<p><b>INFORMATION AVAILABILITY</b></p> <ul style="list-style-type: none"> <li>• Verify related Service Bulletins and/or on-line repair information availability.</li> <li>• Is any related Service Bulletins available?</li> </ul>		<p>the available Service Bulletins.</p> <ul style="list-style-type: none"> <li>• If the vehicle is not repaired, go to the next step.</li> </ul>
		No	Go to the next step.
3	<p><b>VERIFY RELATED PENDING CODE OR STORED DTCs</b></p> <ul style="list-style-type: none"> <li>• Turn the ignition switch off then to the ON position (Engine off).</li> <li>• Verify related pending code or stored DTCs.</li> <li>• Is other DTCs present?</li> </ul>	Yes	Go to the appropriate DTC troubleshooting. (See <b><u>DTC TABLE [MZI-3.5]</u></b> .)
		No	Go to the next step.
4	<p><b>VISUALLY INSPECT COMPONENTS FOR SMALL LEAKS</b></p> <ul style="list-style-type: none"> <li>• Check for presence of fuel-filler cap. Do not tighten or check for correct installation at this time.</li> <li>• Verify that the CV solenoid valve is properly seated on the charcoal canister.</li> <li>• Visually inspect for cut or loose connections to the fuel vapor hoses/tubes in the following locations: <ul style="list-style-type: none"> <li>○ Charcoal canister to CV solenoid valve.</li> <li>○ Charcoal canister to evaporative emission valve component.</li> <li>○ Evaporative emission valve component to the fuel tank (if applicable).</li> </ul> </li> <li>• Check for fuel-filler pipe damage.</li> <li>• Is a concern with a hose, tube, connection, or valve visually evident?</li> </ul>	Yes	Repair or install a new component if necessary. Go to Step 13.
		No	Go to the next step.
5	<p><b>INSPECT FOR SMALL SYSTEM LEAKS FROM EVAP TEST PORT</b></p>	Yes	Go to the next step.

## 2007 Mazda CX-9 Grand Touring

2007 ENGINE PERFORMANCE On-Board Diagnostic (MZI-3.5) - CX-9

	<ul style="list-style-type: none"> <li>• Connect the EVAP system tester SST 218-0002 or equivalent to the EVAP test port.</li> <li>• Perform the EVAP System Leak Test.</li> </ul> <p>(see <b><u>ENGINE CONTROL SYSTEM OPERATION INSPECTION [MZI-3.5]</u></b> .)</p> <ul style="list-style-type: none"> <li>• Does the system pass the leak test?</li> </ul>	No	Replace a new component if necessary. Go to Step 7.
6	<b>INSPECT FOR SMALL LEAKS AT FUEL-FILLER CAP AND EVAPORATIVE TEST PORT</b> <ul style="list-style-type: none"> <li>• Turn the ignition switch to the ON position [(Engine off).</li> <li>• Close CV solenoid valve using the EVAPCV PID.</li> <li>• Using the EVAP system tester, check for leaks around the fuel-filler cap and the evaporative test port.</li> <li>• Is a leak detected?</li> </ul>	Yes	Repair or replace the component if necessary. Go to Step 11.
		No	Remove the Leak Tester. Install the fuel-filler cap. Go to Step 13.
7	<b>VISUALLY INSPECT FUEL-FILLER CAP</b> <ul style="list-style-type: none"> <li>• Visually inspect the fuel-filler cap for damage.</li> <li>• Is the fuel-filler cap damaged?</li> </ul>	Yes	Replace the fuel-filler cap, then go to the next step.
		No	Go to Step 12.
8	<b>INSPECT FOR SMALL LEAK WITH TESTER SET AT FILL POSITION</b> <ul style="list-style-type: none"> <li>• Turn the ignition switch to the ON position (Engine off).</li> <li>• Close CV solenoid valve using the EVAPCV PID from the output test mode.</li> <li>• Pressurize EVAP system to 3.48 kPa (PID FTP_H2O displays "14").</li> <li>• Does the pressure hold between 3.43 and 3.53 kPa (PID FTP_H2O</li> </ul>	Yes	Go to the next step.
		No	Go to step 10.

## 2007 Mazda CX-9 Grand Touring

2007 ENGINE PERFORMANCE On-Board Diagnostic (MZI-3.5) - CX-9

	displays "13.80" and "14.20")?		
9	<b>INSPECT FOR LEAKS IN COMPLETE EVAP SYSTEM</b> <ul style="list-style-type: none"> <li>• Verify CV solenoid valve is closed.</li> <li>• Verify system is pressurized to 3.48 kPa (14 in-H<sub>2</sub>O).</li> <li>• Using the ultrasonic leak detector, check the following EVAP system locations:                             <ul style="list-style-type: none"> <li>○ EVAP return tube to CV solenoid valve.</li> <li>○ CV solenoid valve to charcoal canister-CV solenoid valve component.</li> <li>○ Charcoal canister-CV solenoid valve component to fuel tank.</li> <li>○ fuel-filler cap and fuel-filler pipe.</li> </ul> </li> <li>• Is a leak detected?</li> </ul>	Yes	Repair or replace the component if necessary. Go to Step 12.
		No	Discontinue pressurizing the system. Go to the next step.
10	<b>INSPECT FOR SMALL LEAK FROM EVAP RETURN TUBE TO CHARCOAL CANISTER</b> <ul style="list-style-type: none"> <li>• Disconnect the fuel tank vapor tube at the fuel fuel vapor hose joint and plug the opening in the hose joint.</li> <li>• Turn the ignition switch to the ON position (Engine off).</li> <li>• Close CV solenoid valve using the EVAPCV PID from the output test mode.</li> <li>• Pressurize the EVAP system to 3.48 kPa (14in-H<sub>2</sub>O).</li> <li>• Using the ultrasonic leak detector, check the EVAP system from the intake manifold to the CV solenoid valve.</li> <li>• Is a leak detected?</li> </ul>	Yes	Repair or replace the component if necessary. Go to Step 12.
		No	Open the CV solenoid valve. Go to the next step.
11	<b>INSPECT FOR SMALL LEAK</b>	Yes	Repair or install a new component. Go to



## 2007 Mazda CX-9 Grand Touring

2007 ENGINE PERFORMANCE On-Board Diagnostic (MZI-3.5) - CX-9

	<p><b>BETWEEN FUEL TANK VAPOR TUBE AND FUEL TANK FILLER PIPE</b></p> <ul style="list-style-type: none"> <li>• Transfer the plug from the fuel vapor hose joint to the fuel tank vapor tube.</li> <li>• Pressurize EVAP system to 3.48 kPa (PID FTP_H2O displays "14").</li> <li>• Using the ultrasonic leak detector, check the fuel tank vapor tube to the fuel tank for leaks. Check the FTP sensor, fuel tank vapor tube and the fuel-filler pipe.</li> <li>• Is a leak detected?</li> </ul>		the next step.
		No	Reconnect the fuel vapor tube to the fuel vapor hose joint. Go to Step 12.
12	<p><b>EVAP SYSTEM LEAK TEST</b></p> <ul style="list-style-type: none"> <li>• Connect all disconnected connectors and hoses.</li> <li>• Perform the EVAP System Leak Test.</li> </ul> <p>(see <b><u>ENGINE CONTROL SYSTEM OPERATION INSPECTION [MZI-3.5]</u></b> .)</p> <ul style="list-style-type: none"> <li>• Are the test results normal?</li> </ul>	Yes	Go to the next step.
		No	Leakage still exists. Locate leak point and repair. Repeat this step.
13	<p><b>VERIFY TROUBLESHOOTING OF DTC P0442, P0456 HAS BEEN COMPLETED</b></p> <ul style="list-style-type: none"> <li>• Verify that all disconnected connectors are reconnected.</li> <li>• Turn the ignition switch to the ON position (Engine off).</li> <li>• Clear the DTC from the PCM memory using the M-MDS.</li> <li>• Start the engine and run it at idle.</li> <li>• Retrieve DTCs using the M-MDS.</li> <li>• Is the PENDING CODE for this DTC present?</li> </ul>	Yes	Replace the PCM, then go to the next step. (see <b><u>PCM REMOVAL/INSTALLATION [MZI-3.5]</u></b> .)
		No	Go to the next step.
14	<p><b>VERIFY AFTER REPAIR PROCEDURE</b></p>	Yes	Go to the applicable DTC inspection. (See <b><u>DTC TABLE [MZI-3.5]</u></b> .)

## 2007 Mazda CX-9 Grand Touring

2007 ENGINE PERFORMANCE On-Board Diagnostic (MZI-3.5) - CX-9

<ul style="list-style-type: none"> <li>• Perform the "AFTER REPAIR PROCEDURE".</li>   <li>(See <b><u>AFTER REPAIR PROCEDURE [MZI-3.5].</u></b>)</li>   <li>• Are any DTC present?</li> </ul>	No	Troubleshooting completed.
--	----	----------------------------

### DTC P0443 [MZI-3.5]

#### DTC P0443 (MZI-3.5) DETECTION CONDITION AND POSSIBLE CAUSES

DTC P0443	Purge solenoid valve circuit
<b>DETECTION CONDITION</b>	<ul style="list-style-type: none"> <li>• The PCM monitors the state of the purge solenoid valve circuit output driver. The fails when the signal moves outside the minimum or maximum limit for the commanded state.</li> </ul>
<b>POSSIBLE CAUSE</b>	<ul style="list-style-type: none"> <li>• Purge solenoid valve malfunction</li> <li>• Connector or terminal malfunction</li> <li>• Short to ground between purge solenoid valve terminal B and PCM terminal 1BC</li> <li>• Open circuit between main relay No.1 terminal D and purge solenoid valve terminal B</li> <li>• Short to power supply between purge solenoid valve terminal B and PCM terminal 1BC</li> <li>• Open circuit between purge solenoid valve terminal B and PCM terminal 1BC</li> <li>• PCM malfunction</li> </ul>

## 2007 Mazda CX-9 Grand Touring

2007 ENGINE PERFORMANCE On-Board Diagnostic (MZI-3.5) - CX-9

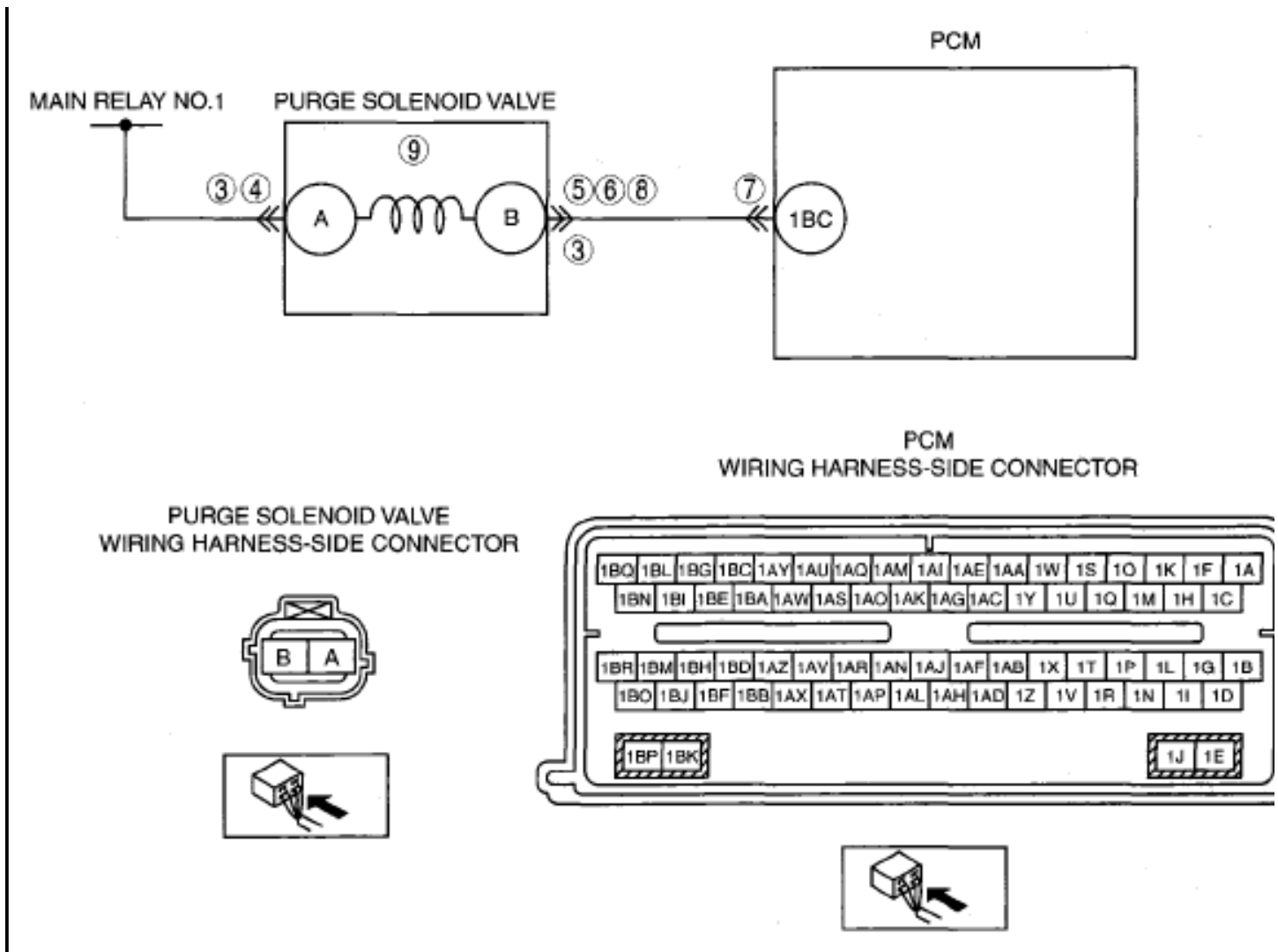

### DIAGNOSTIC PROCEDURE

#### DTC P0443 (MZI-3.5) DIAGNOSTIC PROCEDURE

STEP	INSPECTION		ACTION
1	<b>VERIFY FREEZE FRAME DATA HAS BEEN RECORDED</b>  • Has FREEZE FRAME DATA been recorded?	Yes	Go to the next step.
		No	Record FREEZE FRAME DATA on the repair order, then go to the next step.
2	<b>VERIFY RELATED REPAIR INFORMATION AVAILABILITY</b>  • Verify related Service Bulletins and/or on-line repair information availability.	Yes	Perform repair or diagnosis according to the available Service Bulletins.  • If the vehicle is not repaired, go to the next step.

## 2007 Mazda CX-9 Grand Touring

2007 ENGINE PERFORMANCE On-Board Diagnostic (MZI-3.5) - CX-9

	<ul style="list-style-type: none"> <li>• Is any related Service Bulletins available?</li> </ul>	No	Go to the next step.
3	<b>INSPECT PURGE SOLENOID VALVE CONNECTOR FOR POOR CONNECTION</b> <ul style="list-style-type: none"> <li>• Turn the ignition switch off.</li> <li>• Disconnect purge solenoid valve connector.</li> <li>• Inspect for poor connection (such as damaged/pulled-out pins, corrosion).</li> <li>• Are there any malfunction?</li> </ul>	Yes	Repair or replace suspected part, then go to Step 10.
		No	Go to the next step.
4	<b>INSPECT POWER SUPPLY CIRCUIT FOR OPEN CIRCUIT</b> <ul style="list-style-type: none"> <li>• Turn the ignition switch to the ON position (Engine off).</li> <li>• Measure voltage between purge solenoid valve terminal A and body ground.</li> <li>• Is voltage <b>B+</b> ?</li> </ul>	Yes	Go to the next step.
		No	Repair or replace suspected part, then go to Step 10.
5	<b>INSPECT PURGE SOLENOID VALVE CONTROL CIRCUIT FOR SHORT TO POWER SUPPLY</b> <ul style="list-style-type: none"> <li>• Turn the ignition switch to the ON position (Engine off).</li> <li>• Measure the voltage between purge solenoid valve control terminal B and body ground.</li> <li>• Is voltage <b>B+</b>?</li> </ul>	Yes	Repair or replace suspected part, then go to Step 10.
		No	Go to the next step.
6	<b>INSPECT PURGE SOLENOID VALVE CONTROL CIRCUIT FOR SHORT TO GROUND</b> <ul style="list-style-type: none"> <li>• Turn the ignition switch off.</li> <li>• Inspect for continuity between purge solenoid valve control terminal B and body ground.</li> <li>• Is there continuity?</li> </ul>	Yes	Repair or replace suspected part, then go to the Step 10.
		No	Go to the next step.
7	<b>INSPECT PCM CONNECTOR FOR POOR CONNECTION</b>	Yes	Repair or replace suspected part, then go to Step 10.

## 2007 Mazda CX-9 Grand Touring

2007 ENGINE PERFORMANCE On-Board Diagnostic (MZI-3.5) - CX-9

	<ul style="list-style-type: none"> <li>• Turn the ignition switch off.</li> <li>• Disconnect PCM connector.</li> <li>• Inspect for poor connection (such as damaged/pulled-out pins, corrosion).</li> <li>• Is there any malfunction?</li> </ul>	No	Go to the next step.
8	<b>INSPECT PURGE SOLENOID VALVE CONTROL CIRCUIT FOR OPEN CIRCUIT</b> <ul style="list-style-type: none"> <li>• Turn the ignition switch off.</li> <li>• Inspect continuity between purge solenoid valve terminal B and PCM terminal 1BC.</li> <li>• Is there continuity?</li> </ul>	Yes	Go to the next step.
		No	Repair or replace suspected part, then go to the Step 10.
9	<b>INSPECT PURGE SOLENOID VALVE</b> <ul style="list-style-type: none"> <li>• Inspect the purge solenoid valve.</li> </ul> <p>(see <b><u>PURGE SOLENOID VALVE INSPECTION [MZI-3.5]</u></b> .)</p> <ul style="list-style-type: none"> <li>• Is there any malfunction?</li> </ul>	Yes	Replace purge solenoid valve (see <b><u>PURGE SOLENOID VALVE REMOVAL/INSTALLATION [MZI-3.5]</u></b> .), then go to Step 10.
		No	Go to the next step.
10	<b>VERIFY TROUBLESHOOTING OF DTC P0443 COMPLETED</b> <ul style="list-style-type: none"> <li>• Make sure to reconnect all disconnected connectors.</li> <li>• Clear DTC from PCM memory using M-MDS.</li> <li>• Perform the "KOEO or KOER self-test" using the M-MDS.</li> </ul> <p>(See <b><u>KOEO/KOER SELF TEST [MZI-3.5]</u></b>.)</p> <ul style="list-style-type: none"> <li>• Is the PENDING CODE same DTC present?</li> </ul>	Yes	Replace PCM, then go to the next step. (see <b><u>PCM REMOVAL/INSTALLATION [MZI-3.5]</u></b> .)
		No	Go to the next step.
11	<b>VERIFY AFTER REPAIR PROCEDURE</b> <ul style="list-style-type: none"> <li>• Perform the "AFTER REPAIR</li> </ul>	Yes	Go to the applicable DTC inspection. (See <b><u>DTC TABLE [MZI-3.5]</u></b> .)

## 2007 Mazda CX-9 Grand Touring

2007 ENGINE PERFORMANCE On-Board Diagnostic (MZI-3.5) - CX-9

	PROCEDURE".  (See <b><u>AFTER REPAIR PROCEDURE [MZI-3.5].</u></b> )  • Are any DTCs present?	No	Troubleshooting completed.
--	--	----	----------------------------

### DTC P0446 [MZI-3.5]

#### DTC P0446 (MZI-3.5) DETECTION CONDITION AND POSSIBLE CAUSES

DTC P0446	CV solenoid valve control circuit
<b>DETECTION CONDITION</b>	<ul style="list-style-type: none"><li>• Monitors the CV solenoid valve circuit for an electrical failure. The test fails when the signal moves outside the minimum or maximum allowable calibrated parameters specified by the canister vent duty cycle by PCM command.</li></ul>
<b>POSSIBLE CAUSE</b>	<ul style="list-style-type: none"><li>• CV solenoid valve malfunction</li><li>• Connector or terminal malfunction</li><li>• Short to ground between CV solenoid valve terminal B and PCM terminal 1Z</li><li>• Open circuit between battery and CV solenoid valve terminal A</li><li>• Short to power supply between CV solenoid valve terminal B and PCM terminal 1Z</li><li>• Open circuit between CV solenoid valve terminal B and PCM terminal 1Z</li><li>• PCM malfunction</li></ul>

## 2007 Mazda CX-9 Grand Touring

2007 ENGINE PERFORMANCE On-Board Diagnostic (MZI-3.5) - CX-9

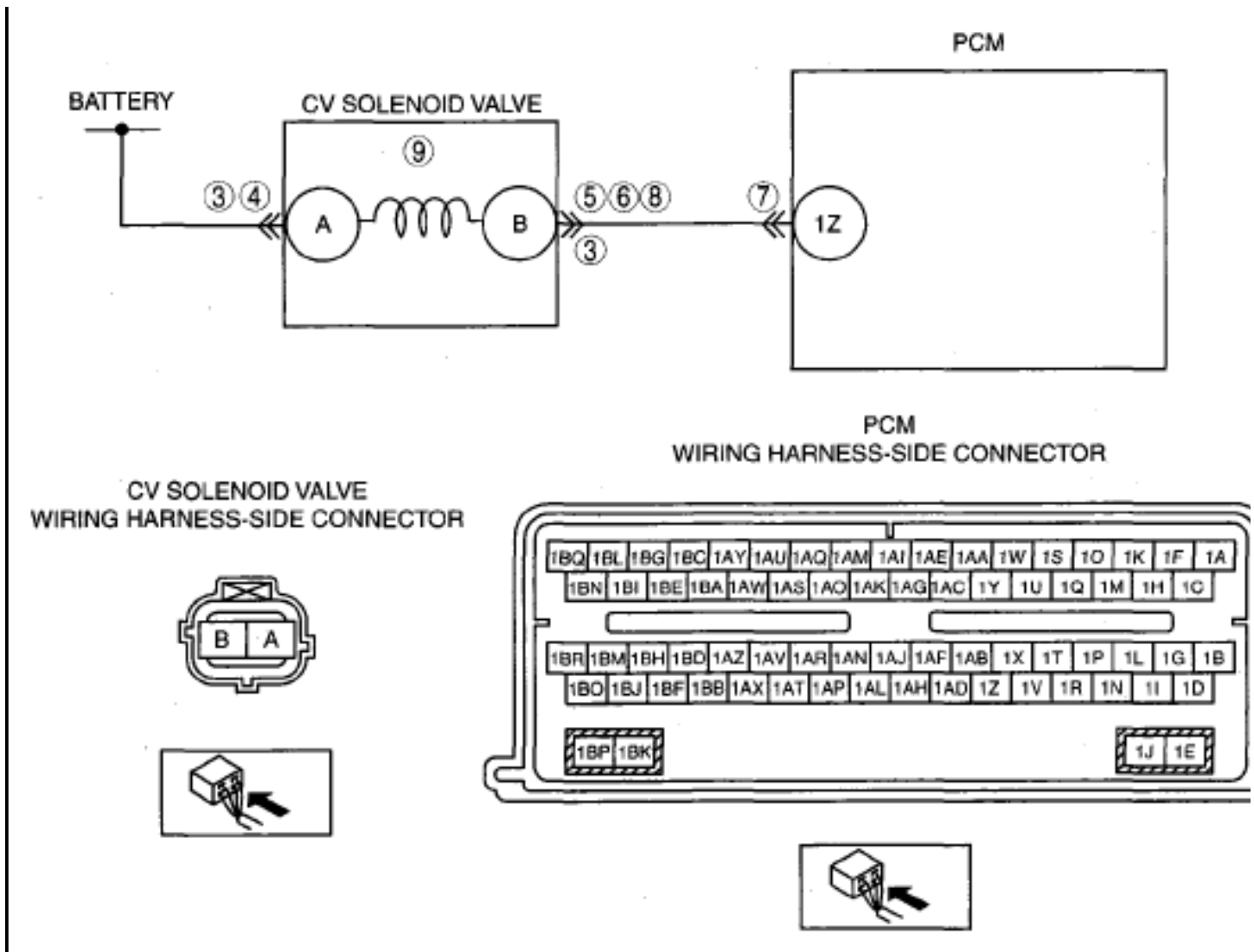

### DIAGNOSTIC PROCEDURE

#### DTC P0446 (MZI-3.5) DIAGNOSTIC PROCEDURE

STEP	INSPECTION		ACTION
1	<b>VERIFY FREEZE FRAME DATA HAS BEEN RECORDED</b>  • Has FREEZE FRAME DATA been recorded?	Yes	Go to the next step.
		No	Record FREEZE FRAME DATA on the repair order, then go to the next step.
2	<b>VERIFY RELATED REPAIR INFORMATION AVAILABILITY</b>  • Verify related Service Bulletins and/or on-line repair information availability.	Yes	Perform repair or diagnosis according to the available Service Bulletins.  • If the vehicle is not repaired, go to the next step.

## 2007 Mazda CX-9 Grand Touring

2007 ENGINE PERFORMANCE On-Board Diagnostic (MZI-3.5) - CX-9

	<ul style="list-style-type: none"> <li>• Is any related Service Bulletins available?</li> </ul>	No	Go to the next step.
3	<b>INSPECT CV SOLENOID VALVE CONNECTOR FOR POOR CONNECTION</b> <ul style="list-style-type: none"> <li>• Turn the ignition switch off.</li> <li>• Disconnect CV solenoid valve connector.</li> <li>• Inspect for poor connection (such as damaged/pulled-out pins, corrosion).</li> <li>• Are there any malfunction?</li> </ul>	Yes	Repair or replace suspected part, then go to Step 10.
		No	Go to the next step.
4	<b>INSPECT POWER SUPPLY CIRCUIT FOR OPEN CIRCUIT</b> <ul style="list-style-type: none"> <li>• Turn the ignition switch to the ON position (Engine off).</li> <li>• Measure voltage between CV solenoid valve terminal A and body ground.</li> <li>• Is voltage <b>B+</b> ?</li> </ul>	Yes	Go to the next step.
		No	Repair or replace suspected part, then go to Step 10.
5	<b>INSPECT CV SOLENOID VALVE CONTROL CIRCUIT FOR SHORT TO POWER SUPPLY</b> <ul style="list-style-type: none"> <li>• Turn the ignition switch to the ON position (Engine off).</li> <li>• Measure the voltage between CV solenoid valve control terminal B and body ground.</li> <li>• Is voltage <b>B+</b> ?</li> </ul>	Yes	Repair or replace suspected part, then go to Step 10.
		No	Go to the next step.
6	<b>INSPECT CV SOLENOID VALVE CONTROL CIRCUIT FOR SHORT TO GROUND</b> <ul style="list-style-type: none"> <li>• Turn the ignition switch off.</li> <li>• Inspect for continuity between CV solenoid valve control terminal B and body ground.</li> <li>• Is the continuity?</li> </ul>	Yes	Repair or replace suspected part, then go to the Step 10.
		No	Go to the next step.
7	<b>INSPECT PCM CONNECTOR FOR POOR CONNECTION</b>	Yes	Repair or replace suspected part, then go to Step 10.



## 2007 Mazda CX-9 Grand Touring

2007 ENGINE PERFORMANCE On-Board Diagnostic (MZI-3.5) - CX-9

	<ul style="list-style-type: none"> <li>• Turn the ignition switch off.</li> <li>• Disconnect PCM connector.</li> <li>• Inspect for poor connection (such as damaged/pulled-out pins, corrosion).</li> <li>• Is there any malfunction?</li> </ul>	No	Go to the next step.
8	<b>INSPECT CV SOLENOID VALVE CONTROL CIRCUIT FOR OPEN CIRCUIT</b> <ul style="list-style-type: none"> <li>• Turn the ignition switch off.</li> <li>• Inspect continuity between CV solenoid valve terminal B and PCM terminal 1Z.</li> <li>• Is there continuity?</li> </ul>	Yes	Go to the next step.
		No	Repair or replace suspected part, then go to the Step 10.
9	<b>INSPECT CV SOLENOID VALVE</b> <ul style="list-style-type: none"> <li>• Inspect the CV solenoid valve.</li> </ul> <p>(see <b><u>CHARCOAL CANISTER, CANISTER VENT (CV) SOLENOID VALVE, AIR FILTER COMPONENT REMOVAL/INSTALLATION [MZI-3.5].</u></b> )</p> <ul style="list-style-type: none"> <li>• Is there any malfunction?</li> </ul>	Yes	Replace CV solenoid valve (see <b><u>CHARCOAL CANISTER, CANISTER VENT (CV) SOLENOID VALVE, AIR FILTER COMPONENT REMOVAL/INSTALLATION [MZI-3.5].</u></b> ), then go to Step 10.
		No	Go to the next step.
10	<b>VERIFY TROUBLESHOOTING OF DTC P0446 COMPLETED</b> <ul style="list-style-type: none"> <li>• Make sure to reconnect all disconnected connectors.</li> <li>• Clear DTC from PCM memory using M-MDS.</li> <li>• Perform the "KOEO or KOER self-test" using the M-MDS.</li> </ul> <p>(See <b><u>KOEO/KOER SELF TEST [MZI-3.5].</u></b> )</p> <ul style="list-style-type: none"> <li>• Is the PENDING CODE same DTC present?</li> </ul>	Yes	Replace PCM, then go to the next step. (see <b><u>PCM REMOVAL/INSTALLATION [MZI-3.5].</u></b> )
		No	Go to the next step.
11	<b>VERIFY AFTER REPAIR PROCEDURE</b>	Yes	Go to the applicable DTC inspection. (See <b><u>DTC TABLE [MZI-3.5].</u></b> )

## 2007 Mazda CX-9 Grand Touring

2007 ENGINE PERFORMANCE On-Board Diagnostic (MZI-3.5) - CX-9

	<ul style="list-style-type: none"> <li>Perform the "AFTER REPAIR PROCEDURE".</li> </ul> <p>(See <b><u>AFTER REPAIR PROCEDURE [MZI-3.5]</u></b>.)</p> <ul style="list-style-type: none"> <li>Are any DTCs present?</li> </ul>	No	Troubleshooting completed.
--	--	----	----------------------------

### DTC P0451 [MZI-3.5]

#### DTC P0451 (MZI-3.5) DETECTION CONDITION AND POSSIBLE CAUSES

<b>DTC P0451</b>	<b>Fuel tank pressure sensor range/performance</b>
<b>DETECTION CONDITION</b>	<p><b>NOTE:</b></p> <ul style="list-style-type: none"> <li>For some vehicle applications, DTC P0451 is set for a fuel tank pressure sensor range (offset) concern. The DTC P0454 replaces the original P0451 for intermittent (noisy) sensor concerns. Until the phase in process is complete, noisy or offset fuel tank pressure sensor concerns may set DTC P0451.</li> <li>The fuel tank pressure changes more than 14 inches of water in 0.10 s. Fuel tank pressure sensor output is offset by +/- 1.7 inches of water.</li> </ul>
<b>POSSIBLE CAUSE</b>	<ul style="list-style-type: none"> <li>Intermittent open or short in the fuel tank pressure sensor or the fuel tank pressure sensor signal</li> <li>Fuel tank pressure sensor malfunction</li> <li>Connector or terminal malfunction</li> <li>PCM malfunction</li> </ul>

#### DIAGNOSTIC PROCEDURE

##### DTC P0451 (MZI-3.5) DIAGNOSTIC PROCEDURE

STEP	INSPECTION		ACTION
1	<b>VERIFY FREEZE FRAME DATA HAS BEEN RECORDED</b> <ul style="list-style-type: none"> <li>Has the FREEZE FRAME DATA been recorded?</li> </ul>	Yes	Go to the next step.
		No	Record FREEZE FRAME DATA on the repair order, then go to the next step.
2	<b>VERIFY RELATED REPAIR INFORMATION AVAILABILITY</b> <ul style="list-style-type: none"> <li>Verify related Service Bulletins and/or on-line repair information availability.</li> <li>Is any related repair information</li> </ul>	Yes	Perform the repair or diagnosis according to the available repair information. <ul style="list-style-type: none"> <li>If the vehicle is not repaired, go to the next step.</li> </ul>
		No	Go to the next step.

## 2007 Mazda CX-9 Grand Touring

2007 ENGINE PERFORMANCE On-Board Diagnostic (MZI-3.5) - CX-9

	available?		
3	<b>VERIFY RELATED PENDING CODE OR STORED DTCs</b> <ul style="list-style-type: none"> <li>• Turn the ignition switch off then to the ON position (Engine off).</li> <li>• Verify related pending code or stored DTCs.</li> <li>• Is other DTCs present?</li> </ul>	Yes	Go to the appropriate DTC troubleshooting. (See <b><u>DTC TABLE [MZI-3.5].</u></b> )
		No	Go to the next step.
4	<b>CLEAR AND ATTEMPT TO RETRIEVE THE DTC</b> <ul style="list-style-type: none"> <li>• Clear the DTC from the PCM memory using the M-MDS.</li> <li>• Turn the ignition switch to the ON position (Engine running).</li> <li>• Run the engine for <b>approx. 10 s .</b></li> <li>• Check for continuous memory DTCs.</li> <li>• Is the same DTC present?</li> </ul>	Yes	Go to the next step.
		No	DTC troubleshooting completed.
5	<b>INSPECT FUEL TANK PRESSURE AND PCM SENSOR CONNECTOR FOR POOR CONNECTION</b> <ul style="list-style-type: none"> <li>• Turn the ignition switch off.</li> <li>• Disconnect the MAF/IAT sensor connector.</li> <li>• Inspect for poor connection (such as damaged/pulled-out pins, corrosion).</li> <li>• Are there any malfunction?</li> </ul>	Yes	Repair or replace suspected part, then go to Step 8.
		No	Go to the next step.
6	<b>INSPECT THE FUEL TANK PRESSURE</b> <ul style="list-style-type: none"> <li>• Inspect the MAF sensor.</li> </ul> <p>(see <b><u>FUEL TANK PRESSURE SENSOR INSPECTION [MZI-3.5] .</u></b>)</p> <ul style="list-style-type: none"> <li>• Is there malfunction?</li> </ul>	Yes	Replace evaporative hose component, then go to Step 8. (see <b><u>FUEL TANK REMOVAL/INSTALLATION [MZI-3.5] .</u></b> )
		No	Go to the next step.
7	<b>INSPECT FOR CORRECT PCM OPERATION</b>	Yes	Go to the next step.

## 2007 Mazda CX-9 Grand Touring

2007 ENGINE PERFORMANCE On-Board Diagnostic (MZI-3.5) - CX-9

	<ul style="list-style-type: none"> <li>• Disconnect all the PCM connectors.</li> <li>• Visually inspect for: <ul style="list-style-type: none"> <li>○ Pushed out pins</li> <li>○ Corrosion</li> </ul> </li> <li>• Connect all the PCM connectors and verify that they seat correctly.</li> <li>• Retrieve DTCs using the M-MDS.</li> <li>• Is the PENDING CODE for this DTC present?</li> </ul>	No	The system is correctly. Go to the next step.
8	<p><b>VERIFY TROUBLESHOOTING OF DTC P0451 COMPLETED</b></p> <ul style="list-style-type: none"> <li>• Verify that all disconnected connectors are reconnected.</li> <li>• Clear the DTC from the PCM memory using the M-MDS.</li> <li>• Perform the "KOEO or KOER self-test" using the M-MDS.</li> </ul> <p>(See <b><u>KOEO/KOER SELF TEST [MZI-3.5]</u></b>.)</p> <ul style="list-style-type: none"> <li>• Start the engine and wait for <b>approx. 10s</b> .</li> <li>• Is the PENDING CODE for the DTC present?</li> </ul>	Yes	Replace the PCM, then go to the next step. (see <b><u>PCM REMOVAL/INSTALLATION [MZI-3.5]</u></b> .)
		No	Go to the next step.
9	<p><b>VERIFY AFTER REPAIR PROCEDURE</b></p> <ul style="list-style-type: none"> <li>• Perform the "AFTER REPAIR PROCEDURE".</li> </ul> <p>(See <b><u>AFTER REPAIR PROCEDURE [MZI-3.5]</u></b> )</p> <ul style="list-style-type: none"> <li>• Are any DTCs present?</li> </ul>	Yes	Go to the applicable DTC inspection. (See <b><u>DTC TABLE [MZI-3.5]</u></b> )
		No	DTC troubleshooting completed.

### DTC P0452 [MZI-3.5]

#### DTC P0452 (MZI-3.5) DETECTION CONDITION AND POSSIBLE CAUSES

<b>DTC P0452</b>	<b>Fuel tank pressure sensor low input</b>
	<ul style="list-style-type: none"> <li>• The PCM monitors the evaporative emission (EVAP) control system fuel tank pre</li> </ul>

## 2007 Mazda CX-9 Grand Touring

2007 ENGINE PERFORMANCE On-Board Diagnostic (MZI-3.5) - CX-9

**DETECTION CONDITION**

sensor input signal to the PCM. The test fails when the signal average drops below minimum allowable calibrated parameter.

**POSSIBLE CAUSE**

- Fuel tank pressure sensor malfunction
- Connector or terminal malfunction
- Short to ground between fuel tank pressure sensor terminal A and PCM terminal 1
- Fuel tank pressure sensor signal circuit and ground circuit for short each other

**FUEL TANK PRESSURE SENSOR**

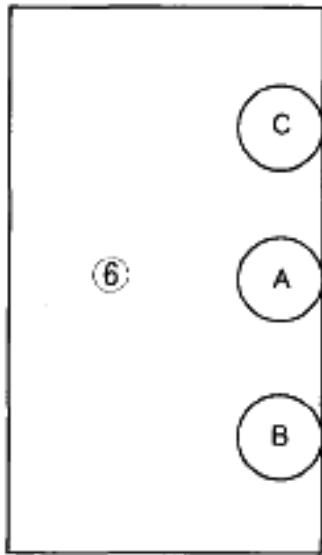

**PCM**

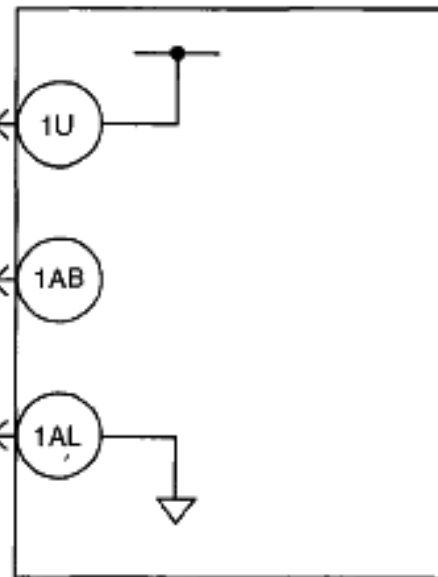

**PCM WIRING HARNESS-SIDE CONNECTOR**

**FUEL TANK PRESSURE SENSOR WIRING HARNESS-SIDE CONNECTOR**

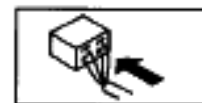
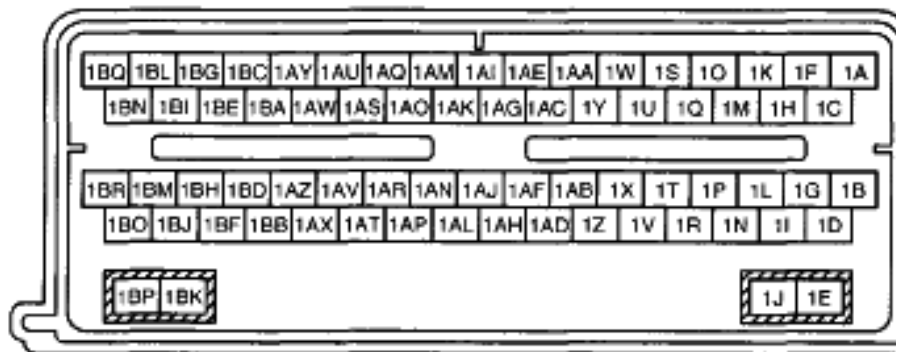

**DIAGNOSTIC PROCEDURE**

## 2007 Mazda CX-9 Grand Touring

2007 ENGINE PERFORMANCE On-Board Diagnostic (MZI-3.5) - CX-9

### DTC P0452 (MZI-3.5) DIAGNOSTIC PROCEDURE

STEP	INSPECTION	ACTION	
1	<b>VERIFY FREEZE FRAME DATA HAS BEEN RECORDED</b> <ul style="list-style-type: none"> <li>• Has the FREEZE FRAME DATA been recorded?</li> </ul>	Yes	Go to the next step.
		No	Record FREEZE FRAME DATA on the repair order, then go to the next step.
2	<b>VERIFY RELATED REPAIR INFORMATION AVAILABILITY</b> <ul style="list-style-type: none"> <li>• Verify related Service Bulletins and/or on-line repair information availability.</li> <li>• Is any related repair information available?</li> </ul>	Yes	Perform the repair or diagnosis according to the available repair information. <ul style="list-style-type: none"> <li>• If the vehicle is not repaired, go to the next step.</li> </ul>
		No	Go to the next step.
3	<b>INSPECT FUEL TANK PRESSURE SENSOR CONNECTOR FOR POOR CONNECTION</b> <ul style="list-style-type: none"> <li>• Turn the ignition switch off.</li> <li>• Disconnect the fuel tank pressure sensor connector.</li> <li>• Inspect for poor connection (such as damaged/pulled-out pins, corrosion).</li> <li>• Are there any malfunction?</li> </ul>	Yes	Repair or replace suspected part, then go to Step 7.
		No	Go to the next step.
4	<b>VERIFY FUEL TANK PRESSURE SIGNAL CIRCUIT FOR SHORT TO GROUND</b> <ul style="list-style-type: none"> <li>• Turn the ignition switch off.</li> <li>• Inspect for continuity between fuel tank pressure sensor terminal A (wiring harness-side) and body ground.</li> <li>• Is there continuity?</li> </ul>	Yes	Repair or replace suspected part, then go to Step 7.
		No	Go to the next step.
5	<b>INSPECT FUEL TANK PRESSURE SENSOR SIGNAL CIRCUIT AND GROUND CIRCUIT FOR SHORT EACH OTHER</b> <ul style="list-style-type: none"> <li>• Turn the ignition switch off.</li> <li>• Disconnect the fuel tank pressure sensor and PCM connector.</li> </ul>	Yes	Go to the next step.
		No	Repair or replace suspected part, then go to Step 7.

## 2007 Mazda CX-9 Grand Touring

2007 ENGINE PERFORMANCE On-Board Diagnostic (MZI-3.5) - CX-9

	<ul style="list-style-type: none"> <li>• Measure resistance between PCM terminal 1AB (wiring harness-side) and PCM terminal 1AL (wiring harness-side)</li> <li>• Is the resistance more than 10 kilohms?</li> </ul>		
6	<p><b>INSPECT FUEL TANK PRESSURE SENSOR</b></p> <ul style="list-style-type: none"> <li>• Perform the fuel tank pressure sensor inspection.</li> </ul> <p>(see <b><u>FUEL TANK PRESSURE SENSOR INSPECTION [MZI-3.5]</u></b> .)</p> <ul style="list-style-type: none"> <li>• Is the fuel tank pressure sensor normal?</li> </ul>	Yes	Go to the next step.
		No	Replace the evaporative hose component, then go to the next step. (see <b><u>FUEL TANK REMOVAL/INSTALLATION [MZI-3.5]</u></b> .)
7	<p><b>VERIFY TROUBLESHOOTING OF DTC P0452 COMPLETED</b></p> <ul style="list-style-type: none"> <li>• Make sure to reconnect all disconnected connectors.</li> <li>• Turn ignition switch to the ON position (Engine off).</li> <li>• Clear the DTC from the PCM memory using the M-MDS.</li> <li>• Start the engine and warm it up completely.</li> <li>• Is same DTC present?</li> </ul>	Yes	Replace the PCM, then go to the next step. (see <b><u>PCM REMOVAL/INSTALLATION [MZI-3.5]</u></b> .)
		No	Go to the next step.
8	<p><b>VERIFY AFTER REPAIR PROCEDURE</b></p> <ul style="list-style-type: none"> <li>• Perform the "After Repair Procedure". (See <b><u>AFTER REPAIR PROCEDURE [MZI-3.5]</u></b> .)</li> <li>• Are any DTCs present?</li> </ul>	Yes	Go to the applicable DTC inspection. (See <b><u>DTC TABLE [MZI-3.5]</u></b> .)
		No	Troubleshooting completed.

### DTC P0453 [MZI-3.5]

#### DTC P0453 (MZI-3.5) DETECTION CONDITION AND POSSIBLE CAUSES

DTC P0453	Fuel tank pressure sensor high input
-----------	--------------------------------------

## 2007 Mazda CX-9 Grand Touring

2007 ENGINE PERFORMANCE On-Board Diagnostic (MZI-3.5) - CX-9

<b>DETECTION CONDITION</b>	<ul style="list-style-type: none"><li>• The PCM monitors the evaporative emission (EVAP) control system fuel tank pre sensor input signal to the PCM. The test fails when the signal average jumps above minimum allowable calibrated parameter.</li></ul>
<b>POSSIBLE CAUSE</b>	<ul style="list-style-type: none"><li>• Fuel tank pressure sensor malfunction</li><li>• Connector or terminal malfunction</li><li>• Open circuit between fuel tank pressure sensor terminal A and PCM terminal 1AF</li><li>• Open circuit between fuel tank pressure sensor terminal B and PCM terminal 1AJ</li><li>• Short to the constant voltage supply circuit between fuel tank pressure sensor terminal A and PCM terminal 1AB</li><li>• Short to power supply between fuel tank pressure sensor terminal C and PCM terminal 1U</li><li>• Fuel tank pressure sensor power circuit and signal circuit are shorted each other</li></ul>



# 2007 Mazda CX-9 Grand Touring

2007 ENGINE PERFORMANCE On-Board Diagnostic (MZI-3.5) - CX-9

FUEL TANK PRESSURE SENSOR

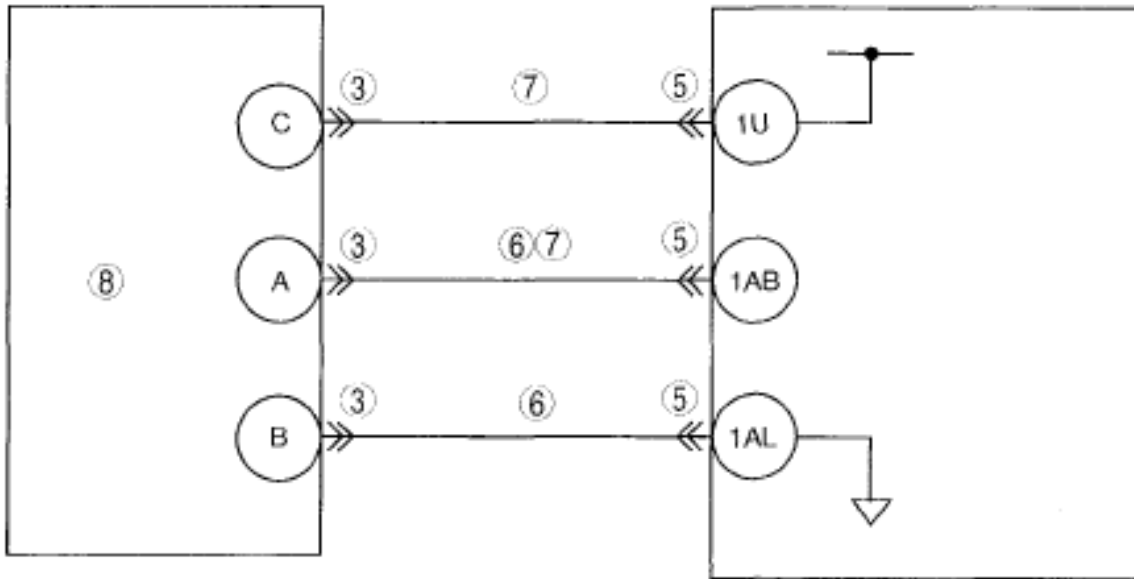

PCM WIRING HARNESS-SIDE CONNECTOR

FUEL TANK PRESSURE SENSOR WIRING HARNESS-SIDE CONNECTOR

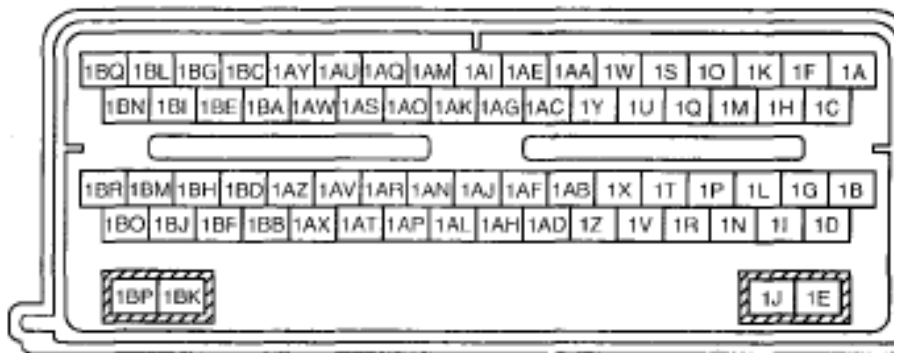
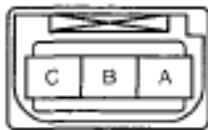

## DIAGNOSTIC PROCEDURE

### DTC P0453 (MZI-3.5) DIAGNOSTIC PROCEDURE

STEP	INSPECTION		ACTION
1	<b>VERIFY FREEZE FRAME DATA HAS BEEN RECORDED</b>  • Has the FREEZE FRAME DATA	Yes	Go to the next step.
		No	Record FREEZE FRAME DATA on the repair order, then go to the next step.

## 2007 Mazda CX-9 Grand Touring

2007 ENGINE PERFORMANCE On-Board Diagnostic (MZI-3.5) - CX-9

	been recorded?		
2	<b>VERIFY RELATED REPAIR INFORMATION AVAILABILITY</b> <ul style="list-style-type: none"> <li>• Verify related Service Bulletins and/or on-line repair information availability.</li> <li>• Is any related repair information available?</li> </ul>	Yes	Perform the repair or diagnosis according to the available repair information. <ul style="list-style-type: none"> <li>• If the vehicle is not repaired, go to the next step.</li> </ul>
		No	Go to the next step.
3	<b>INSPECT FUEL TANK PRESSURE SENSOR CONNECTION FOR POOR CONNECTION</b> <ul style="list-style-type: none"> <li>• Turn the ignition switch off.</li> <li>• Disconnect fuel tank pressure sensor connector.</li> <li>• Inspect for poor connection (such as damaged/pulled-out pins, corrosion).</li> <li>• Are there any malfunction?</li> </ul>	Yes	Repair or replace suspected part, then go to Step 9.
		No	Go to the next step.
4	<b>VERIFY FUEL TANK PRESSURE SENSOR SIGNAL CIRCUIT FOR SHORT TO POWER SUPPLY</b> <ul style="list-style-type: none"> <li>• Turn the ignition switch to the ON position (Engine off).</li> <li>• Measure the voltage between the following terminals:                             <ul style="list-style-type: none"> <li>○ Fuel tank pressure sensor terminal A (wiring harness-side) and body ground.</li> <li>○ Fuel tank pressure sensor terminal C (wiring harness-side) and body ground.</li> </ul> </li> <li>• Are there voltage <b>B+</b> ?</li> </ul>	Yes	Repair or replace suspected part, then go to Step 9.
		No	Go to the next step.
5	<b>INSPECT PCM CONNECTOR FOR POOR CONNECTION</b> <ul style="list-style-type: none"> <li>• Turn the ignition switch off.</li> <li>• Disconnect the fuel tank pressure sensor and PCM connector.</li> <li>• Inspect for poor connection (such as damaged/pulled-out pins, corrosion).</li> </ul>	Yes	Repair or replace suspected part, then go to Step 9.
		No	Go to the next step.

## 2007 Mazda CX-9 Grand Touring

2007 ENGINE PERFORMANCE On-Board Diagnostic (MZI-3.5) - CX-9

	<ul style="list-style-type: none"> <li>• Is there any malfunction?</li> </ul>		
6	<p><b>VERIFY FUEL TANK PRESSURE SENSOR CIRCUIT FOR OPEN CIRCUIT</b></p> <ul style="list-style-type: none"> <li>• Inspect for continuity between the following circuits:                             <ul style="list-style-type: none"> <li>○ Fuel tank pressure sensor connector terminal A (harness-side) and PCM connector terminal 1AB.</li> <li>○ Fuel tank pressure sensor connector terminal B (harness-side) and PCM connector terminal 1AL</li> </ul> </li> <li>• Are there continuity?</li> </ul>	Yes	Go to the next step.
		No	Repair or replace suspected part, then go to Step 9.
7	<p><b>INSPECT FUEL TANK PRESSURE SENSOR SIGNAL CIRCUIT AND POWER CIRCUIT FOR SHORT EACH OTHER</b></p> <ul style="list-style-type: none"> <li>• Turn the ignition switch off.</li> <li>• Disconnect the fuel tank pressure sensor and PCM connector,</li> <li>• Measure resistance between PCM connector terminal 1 U (harness-side) and CM connector terminal 1AB (harness-side).</li> <li>• Is the resistance more than 1 0 kilohms?</li> </ul>	Yes	Go to the next step.
		No	Repair or replace suspected part, then go to Step 9.
8	<p><b>INSPECT FUEL TANK PRESSURE SENSOR</b></p> <ul style="list-style-type: none"> <li>• Inspect the fuel tank pressure sensor.</li> </ul> <p>(see <b><u>FUEL TANK PRESSURE SENSOR INSPECTION [MZI-3.5]</u></b> .)</p> <ul style="list-style-type: none"> <li>• Is the fuel tank pressure sensor normal?</li> </ul>	Yes	Go to the next step.
		No	Replace the evaporative hose component, then go to the next step. (see <b><u>FUEL TANK REMOVAL/INSTALLATION [MZI-3.5]</u></b> .)
9	<p><b>VERIFY TROUBLESHOOTING OF DTC P0453 COMPLETED</b></p>	Yes	Replace the PCM, then go to the next step. (see <b><u>PCM</u></b>

## 2007 Mazda CX-9 Grand Touring

2007 ENGINE PERFORMANCE On-Board Diagnostic (MZI-3.5) - CX-9

	<ul style="list-style-type: none"> <li>• Make sure to reconnect all disconnected connectors.</li> <li>• Turn ignition switch to the ON position (Engine off).</li> <li>• Clear the DTC from the PCM memory using the M-MDS.</li> <li>• Start the engine and warm it up completely.</li> <li>• Is same DTC present?</li> </ul>		<b>REMOVAL/INSTALLATION [MZI-3.5] .)</b>
		No	Go to the next step.
10	<b>VERIFY AFTER REPAIR PROCEDURE</b> <ul style="list-style-type: none"> <li>• Perform the "After Repair Procedure".</li> </ul> <p>(See <b>AFTER REPAIR PROCEDURE [MZI-3.5].</b>)</p> <ul style="list-style-type: none"> <li>• Are any DTCs present?</li> </ul>	Yes	Go to the applicable DTC inspection. (See <b>DTC TABLE [MZI-3.5].</b> )
		No	Troubleshooting completed.

### DTC P0454 [MZI-3.5]

#### DTC P0454 (MZI-3.5) DETECTION CONDITION AND POSSIBLE CAUSES

<b>DTC P0454</b>	<b>Fuel tank pressure sensor intermittent</b>
<b>DETECTION CONDITION</b>	<ul style="list-style-type: none"> <li>• The fuel tank pressure changes more than 14 inches of water in 0.10 s.</li> </ul>
<b>POSSIBLE CAUSE</b>	<ul style="list-style-type: none"> <li>• Intermittent open or short in the fuel tank pressure sensor or the fuel tank pressure sensor signal</li> <li>• Fuel tank pressure sensor malfunction</li> </ul>

#### DIAGNOSTIC PROCEDURE

#### DTC P0454 (MZI-3.5) DIAGNOSTIC PROCEDURE

STEP	INSPECTION		ACTION
1	<b>VERIFY FREEZE FRAME DATA HAS BEEN RECORDED</b> <ul style="list-style-type: none"> <li>• Has FREEZE FRAME DATA been recorded?</li> </ul>	Yes	Go to the next step.
		No	Record FREEZE FRAME DATA on the repair order, then go to the next step.
2	<b>VERIFY RELATED REPAIR INFORMATION AVAILABILITY</b> <ul style="list-style-type: none"> <li>• Verify related Service Bulletins</li> </ul>	Yes	Perform repair or diagnosis according to the available Service Bulletins. <ul style="list-style-type: none"> <li>• If the vehicle is not repaired, go to</li> </ul>

## 2007 Mazda CX-9 Grand Touring

2007 ENGINE PERFORMANCE On-Board Diagnostic (MZI-3.5) - CX-9

	and/or on-line repair information availability.		the next step.
	<ul style="list-style-type: none"> <li>Is any related Service Bulletins available?</li> </ul>	No	Go to the next step.
3	<b>VERIFY RELATED PENDING CODE OR STORED DTCs</b> <ul style="list-style-type: none"> <li>Turn the ignition switch off then to the ON position (Engine off).</li> <li>Verify related pending code or stored DTCs.</li> <li>Is other DTCs present?</li> </ul>	Yes	Go to the appropriate DTC troubleshooting. (See <b><u>DTC TABLE [MZI-3.5]</u></b> .)
		No	Perform the "INTERMITTENT CONCERN TROUBLESHOOTING". Then go to the next step.
4	<b>VERIFY TROUBLESHOOTING OF DTC P0454 HAS BEEN COMPLETED</b> <ul style="list-style-type: none"> <li>Verify that all disconnected connectors reconnected.</li> <li>Clear the DTC from the PCM memory using the M-MDS.</li> <li>Perform the "KOEO or KOER self-test" using the M-MDS.</li> </ul> <p>(See <b><u>KOEO/KOER SELF TEST [MZI-3.5]</u></b>.)</p> <ul style="list-style-type: none"> <li>Is the PENDING CODE for the DTC present?</li> </ul>	Yes	Replace the PCM, then go to the next step. (see <b><u>PCM REMOVAL/INSTALLATION [MZI-3.5]</u></b> .)
		No	Go to the next step.
5	<b>VERIFY AFTER REPAIR PROCEDURE</b> <ul style="list-style-type: none"> <li>Perform the "AFTER REPAIR PROCEDURE".</li> </ul> <p>(See <b><u>AFTER REPAIR PROCEDURE [MZI-3.5]</u></b>.)</p> <ul style="list-style-type: none"> <li>Are any DTCs present?</li> </ul>	Yes	Go to the applicable DTC inspection. (See <b><u>DTC TABLE [MZI-3.5]</u></b> .)
		No	Troubleshooting completed.

### DTC P0455 [MZI-3.5]

#### DTC P0455 (MZI-3.5) DETECTION CONDITION AND POSSIBLE CAUSES

<b>DTC P0455</b>	<b>Evaporative emission system leak detected (gross leak/no flow)</b>
<b>DETECTION</b>	<ul style="list-style-type: none"> <li>P0455 indicates that a substantial leak or blockage has been detected in the</li> </ul>

## 2007 Mazda CX-9 Grand Touring

2007 ENGINE PERFORMANCE On-Board Diagnostic (MZI-3.5) - CX-9

<b>CONDITION</b>	EVAP system when there is -1.74 kPa (PID FTP_H2O displays "-7.0" or less vacuum for a 30 seconds evaluation time.
<b>POSSIBLE CAUSE</b>	<ul style="list-style-type: none"> <li>• After-market EVAP hardware (such as fuel-filler cap) not conforming to required specifications.</li> <li>• Disconnected or cracked fuel chopping timer tube, CV solenoid valve outlet tube or EVAP return tube.</li> <li>• CV solenoid valve stuck closed</li> <li>• Damaged or missing fuel-filler cap.</li> <li>• Insufficient fuel-filler cap installation.</li> <li>• Loose fuel vapor hose/tube connections to EVAP system components.</li> <li>• Blockages or restrictions in fuel vapor hoses/tubes.</li> <li>• Rollover valve blocked or fuel shut-off valve.</li> <li>• CV solenoid valve stuck open.</li> <li>• Mechanically inoperative Fuel tank pressure sensor.</li> <li>• Damaged charcoal canister.</li> </ul>

### DIAGNOSTIC PROCEDURE

#### DTC P0455 (MZI-3.5) DIAGNOSTIC PROCEDURE

STEP	INSPECTION		ACTION
1	<b>VERIFY FREEZE FRAME DATA HAS BEEN RECORDED</b> <ul style="list-style-type: none"> <li>• Has FREEZE FRAME DATA been recorded?</li> </ul>	Yes	Go to the next step.
		No	Record FREEZE FRAME DATA on the repair order, then go to the next step.
2	<b>VERIFY RELATED REPAIR INFORMATION AVAILABILITY</b> <ul style="list-style-type: none"> <li>• Verify related Service Bulletins and/or on-line repair information availability.</li> <li>• Is any related Service Bulletins available?</li> </ul>	Yes	Perform repair or diagnosis according to the available Service Bulletins. <ul style="list-style-type: none"> <li>• If the vehicle is not repaired, go to the next step.</li> </ul>
		No	Go to the next step.
3	<b>VERIFY RELATED PENDING CODE OR STORED DTCs</b> <ul style="list-style-type: none"> <li>• Turn the ignition switch off then to the ON position (Engine off).</li> <li>• Verify related pending code or stored DTCs.</li> <li>• Are other DTCs present?</li> </ul>	Yes	Go to the appropriate DTC troubleshooting. (See <b><u>DTC TABLE [MZI-3.5].</u></b> )
		No	Go to the next step.
4	<b>VISUALLY INSPECT FOR LARGE</b>	Yes	Repair or replace the EVAP components if

## 2007 Mazda CX-9 Grand Touring

2007 ENGINE PERFORMANCE On-Board Diagnostic (MZI-3.5) - CX-9

<p><b>EVAP SYSTEM LEAK</b></p> <ul style="list-style-type: none"> <li>• Check for the presence of a fuel-filler cap. Do not tighten or check for correct installation at this time.</li> <li>• Verify that both the input port vacuum hose and EVAP return tube are attached to the CV solenoid valve.</li> <li>• Verify that the CV solenoid valve is properly attached to the charcoal canister.</li> <li>• Visually inspect for disconnected or cracked fuel vapor hoses/tubes between the intake manifold and the following components:             <ul style="list-style-type: none"> <li>○ CV solenoid valve</li> <li>○ Charcoal canister</li> <li>○ Fuel shut-off valve</li> </ul> </li> <li>• Check for damage to the fuel-filler pipe and the fuel tank.</li> <li>• Is a concern visually evident?</li> </ul>	<p>necessary.            (see <b><u>FUEL TANK REMOVAL/INSTALLATION [MZI-3.5]</u></b> .)            (see <b><u>FUEL TANK PRESSURE SENSOR INSPECTION [MZI-3.5]</u></b> .)            (see <b><u>CHARCOAL CANISTER, CANISTER VENT (CV) SOLENOID VALVE, AIR FILTER COMPONENT REMOVAL/INSTALLATION [MZI-3.5]</u></b> .)            Go to Step 7.</p>		
<p style="text-align: center;">5</p>	<p style="text-align: center;">No</p>	<p>Go to the next step.</p>	
<p><b>INSPECT FOR EVAP SYSTEM LEAKS</b></p> <ul style="list-style-type: none"> <li>• Disconnect the EVAP return tube from the intake manifold and plug the EVAP return tube.</li> <li>• Connect the EVAP System Leak Tester to the EVAP test port.</li> <li>• Perform the EVAP System Leak Test.</li> </ul> <p>(see <b><u>ENGINE CONTROL SYSTEM OPERATION INSPECTION [MZI-3.5]</u></b> .)</p> <ul style="list-style-type: none"> <li>• Does the pressure stay above 1.99 kPa (PID FTP_H2O displays "8")?</li> </ul>	<p style="text-align: center;">Yes</p>	<p>Go to the next step.</p>	
	<p style="text-align: center;">No</p>	<p>Verify that the fuel-filler cap is installed correctly. Repair or install a new components if necessary. Go to Step 8.</p>	
<p style="text-align: center;">6</p>	<p><b>INSPECT FOR BLOCKAGE BETWEEN CV SOLENOID VALVE AND FUEL VAPOR HOSE JOINT</b></p> <ul style="list-style-type: none"> <li>• Turn the ignition switch to the ON</li> </ul>	<p style="text-align: center;">Yes</p>	<p>Go to the next step.</p>

## 2007 Mazda CX-9 Grand Touring

2007 ENGINE PERFORMANCE On-Board Diagnostic (MZI-3.5) - CX-9

	<p>position (Engine off).</p> <ul style="list-style-type: none"> <li>• Using M-MDS tester, select the Diagnostic Data Link.</li> <li>• Select the PCM.</li> <li>• Select the Active Command Modes.</li> <li>• Select the Output Test Mode.</li> <li>• Close the CV solenoid valve using the EVMV PID.</li> <li>• Pressurize the EVAP system to 3.48 kPa (PID FTP_H2O displays "14").</li> <li>• Press STOP (#4) on M-MDS tester to open the EVMV.</li> <li>• Does the pressure drop immediately?</li> </ul>	No	Replace the fuel tank vapor line(s). Go to Step 8.
7	<p><b>INSPECT FOR MALFUNCTIONING CV SOLENOID VALVE OR FUEL TANK PRESSURE SENSOR</b></p> <ul style="list-style-type: none"> <li>• Were both P0455 and P1443 present at Step 1?</li> </ul>	Yes	<p>Replace the CV solenoid valve. (see <b><u>CHARCOAL CANISTER, CANISTER VENT (CV) SOLENOID VALVE, AIR FILTER COMPONENT REMOVAL/INSTALLATION [MZI-3.5]01-16 EVAPORATIVE EMISSION CANISTERPURGE VALVE.</u></b> )</p> <p>Go to the next step.</p>
		No	<p>Replace the evaporative hose component. (see <b><u>FUEL TANK REMOVAL/INSTALLATION [MZI-3.5]</u></b> .) Go to the next step.</p>
8	<p><b>EVAP SYSTEM LEAK TEST</b></p> <ul style="list-style-type: none"> <li>• Connect all disconnected connectors and hoses.</li> <li>• Perform the EVAP System Leak Test.</li> </ul> <p>(see <b><u>ENGINE CONTROL SYSTEM OPERATION INSPECTION [MZI-3.5]</u></b> .)</p> <ul style="list-style-type: none"> <li>• Are the test results normal?</li> </ul>	Yes	Go to the next step.
		No	Leakage still exists. Locate leak point and repair. Repeat this step.
9	<p><b>VERIFY TROUBLESHOOTING OF DTC P0455 HAS BEEN COMPLETED</b></p>	Yes	<p>Replace the PCM, then go to the next step. (see <b><u>PCM REMOVAL/INSTALLATION [MZI-3.5]</u></b> .)</p>



## 2007 Mazda CX-9 Grand Touring

### 2007 ENGINE PERFORMANCE On-Board Diagnostic (MZI-3.5) - CX-9

	<ul style="list-style-type: none"> <li>• Verify that all disconnected connectors are reconnected.</li> <li>• Turn the ignition switch to the ON position (Engine off).</li> <li>• Clear the DTC from the PCM memory using the M-MDS.</li> <li>• Start the engine and run it at idle.</li> <li>• Retrieve DTCs using the M-MDS.</li> <li>• Is the PENDING CODE for this DTC present?</li> </ul>	No	Go to the next step.
10	<b>VERIFY AFTER REPAIR PROCEDURE</b> <ul style="list-style-type: none"> <li>• Perform the "AFTER REPAIR PROCEDURE".</li> </ul> <p>(See <b><u>AFTER REPAIR PROCEDURE [MZI-3.5].</u></b>)</p> <ul style="list-style-type: none"> <li>• Are any DTC present?</li> </ul>	Yes	Go to the applicable DTC inspection. (See <b><u>DTC TABLE [MZI-3.5].</u></b> )
		No	Troubleshooting completed.

## DTC P0457 [MZI-3.5]

### DTC P0457 (MZI-3.5) DETECTION CONDITION AND POSSIBLE CAUSES

<b>DTC P0457</b>	<b>Evaporative emission system leak detected (fuel cap loose/off)</b>
<b>DETECTION CONDITION</b>	<ul style="list-style-type: none"> <li>• P0457 indicates that the initial vacuum could not be achieved after a refueling event and the purge vapor flow is excessive (gross leak).</li> </ul>
<b>POSSIBLE CAUSE</b>	<ul style="list-style-type: none"> <li>• Missing or loose fuel filler cap.</li> </ul>

### DIAGNOSTIC PROCEDURE

#### DTC P0457 (MZI-3.5) DIAGNOSTIC PROCEDURE

STEP	INSPECTION		ACTION
1	<b>VERIFY FREEZE FRAME DATA HAS BEEN RECORDED</b> <ul style="list-style-type: none"> <li>• Has FREEZE FRAME DATA been recorded?</li> </ul>	Yes	Go to the next step.
		No	Record FREEZE FRAME DATA on the repair order, then go to the next step.
2	<b>VERIFY RELATED REPAIR INFORMATION AVAILABILITY</b> <ul style="list-style-type: none"> <li>• Verify related Service Bulletins and/or on-line repair information</li> </ul>	Yes	Perform repair or diagnosis according to the available Service Bulletins. <ul style="list-style-type: none"> <li>• If the vehicle is not repaired, go to the next step.</li> </ul>

## 2007 Mazda CX-9 Grand Touring

2007 ENGINE PERFORMANCE On-Board Diagnostic (MZI-3.5) - CX-9

	<p>availability.</p> <ul style="list-style-type: none"> <li>• Is any related Service Bulletins available?</li> </ul>	No	Go to the next step.
3	<p><b>VERIFY RELATED PENDING CODE OR STORED DTCs</b></p> <ul style="list-style-type: none"> <li>• Turn the ignition switch off then to the ON position (Engine off).</li> <li>• Verify related pending code or stored DTCs.</li> <li>• Are other DTCs present?</li> </ul> <p><b>NOTE:</b></p> <ul style="list-style-type: none"> <li>• If DTC P0455 is present, diagnose that DTC first.</li> </ul> <p>(see <u>ENGINE CONTROL SYSTEM OPERATION INSPECTION [MZI-3.5]</u> .)</p>	Yes	Go to the appropriate DTC troubleshooting. (See <u>DTC TABLE [MZI-3.5]</u> .)
		No	Go to the next step.
4	<p><b>INSPECT FOR MISSING OR LEAKING FUEL FILLER CAP</b></p> <ul style="list-style-type: none"> <li>• Check for missing or loose fuel filler cap.</li> <li>• Check for possible cross-threaded fuel filler cap.</li> <li>• Is a concern present?</li> </ul>	Yes	Repair or replace if necessary. Go to the next step.
		No	Go to Step 6.
5	<p><b>EVAP SYSTEM LEAK TEST</b></p> <ul style="list-style-type: none"> <li>• Perform the EVAP system leak test.</li> </ul> <p>(see <u>ENGINE CONTROL SYSTEM OPERATION INSPECTION [MZI-3.5]</u> .)</p> <ul style="list-style-type: none"> <li>• Are the test results normal?</li> </ul>	Yes	Go to Step 6.
		No	Leakage still exists. Go to the P0455 Troubleshooting. (see <u>ENGINE CONTROL SYSTEM OPERATION INSPECTION [MZI-3.5]</u> .)
6	<p><b>VERIFY TROUBLESHOOTING OF DTC P0457 HAS BEEN COMPLETED</b></p> <ul style="list-style-type: none"> <li>• Verify that all disconnected connectors are reconnected.</li> <li>• Turn the ignition switch to the ON</li> </ul>	Yes	Replace the PCM, then go to the next step. (see <u>PCM REMOVAL/INSTALLATION [MZI-3.5]</u> .)

## 2007 Mazda CX-9 Grand Touring

2007 ENGINE PERFORMANCE On-Board Diagnostic (MZI-3.5) - CX-9

	<p>position (Engine off).</p> <ul style="list-style-type: none"> <li>• Clear the DTC from the PCM memory using the M-MDS.</li> <li>• Start the engine and run it at idle.</li> <li>• Retrieve DTCs using the M-MDS.</li> <li>• Is the PENDING CODE for this DTC present?</li> </ul>	No	Go to the next step.
7	<p><b>VERIFY AFTER REPAIR PROCEDURE</b></p> <ul style="list-style-type: none"> <li>• Perform the "AFTER REPAIR PROCEDURE".</li> </ul> <p>(See <b><u>AFTER REPAIR PROCEDURE [MZI-3.5].</u></b>)</p> <ul style="list-style-type: none"> <li>• Are any DTC present?</li> </ul>	Yes	Go to the applicable DTC inspection. (See <b><u>DTC TABLE [MZI-3.5].</u></b> )
		No	Troubleshooting completed.

### DTC P0460 [MZI-3.5]

#### DTC P0460 (MZI-3.5) DETECTION CONDITION AND POSSIBLE CAUSES

DTC P0460	Fuel level sensor circuit
<b>DETECTION CONDITION</b>	<ul style="list-style-type: none"> <li>• The PCM monitors the fuel level input communications network message for a concern. The test fails when the PCM determines that the value of the fuel level input signal is stuck. The PCM calculates the amount of fuel used during operation. If the fuel level input signal does not change or does not correspond with the calculated fuel usage, the DTC is set.</li> </ul>
<b>POSSIBLE CAUSE</b>	<ul style="list-style-type: none"> <li>• Empty fuel tank</li> <li>• Fuel pump malfunction</li> <li>• Incorrectly installed fuel gauge</li> <li>• Instrument cluster malfunction</li> <li>• Fuel level input signal circuit malfunction</li> <li>• Overfilled fuel tank</li> <li>• Fuel gauge malfunction Stuck float arm</li> </ul>

#### DIAGNOSTIC PROCEDURE

#### DTC P0460 (MZI-3.5) DIAGNOSTIC PROCEDURE

STEP	INSPECTION	ACTION	
1	<b>VERIFY FREEZE FRAME DATA HAS BEEN RECORDED</b>	Yes	Go to the next step.
		No	Record the FREEZE FRAME DATA on

## 2007 Mazda CX-9 Grand Touring

2007 ENGINE PERFORMANCE On-Board Diagnostic (MZI-3.5) - CX-9

	<ul style="list-style-type: none"> <li>Has FREEZE FRAME DATA been recorded?</li> </ul>		the repair order, then go to the next step.
2	<b>VERIFY REPAIR INFORMATION AVAILABILITY</b> <ul style="list-style-type: none"> <li>Verify related Service Bulletins availability.</li> <li>Is any related Service Bulletins available?</li> </ul>	Yes	Perform repair or diagnosis according to the available Service Bulletins. If the vehicle is not repaired, go to the next step.
		No	Go to the next step.
3	<b>VERIFY RELATED PENDING CODE OR STORED DTCs</b> <ul style="list-style-type: none"> <li>Turn the ignition switch off then to the ON position (Engine off).</li> <li>Verify related pending code or stored DTCs.</li> <li>Is other DTCs present?</li> </ul>	Yes	Go to the appropriate DTC troubleshooting. (See <b><u>DTC TABLE [MZI-3.5]</u></b> .)
		No	Go to the next step.
4	<b>VERIFY STORED DTC IN INSTRUMENT CLUSTER</b> <ul style="list-style-type: none"> <li>Turn the ignition switch off then to the ON position (Engine off).</li> <li>Verify stored DTCs in instrument cluster.</li> <li>Is other DTCs present?</li> </ul>	Yes	Go to the appropriate DTC inspection. (see <b><u>DTC TABLE [INSTRUMENT CLUSTER]</u></b> .)
		No	Go to the next step.
5	<b>VERIFY TROUBLESHOOTING OF DTC P0460 HAS BEEN COMPLETED</b> <ul style="list-style-type: none"> <li>Verify that all disconnected connectors reconnected.</li> <li>Clear the DTC from the PCM memory using the M-MDS.</li> <li>Perform the "KOE0/KOER self-test".</li> </ul> <p>(See <b><u>KOE0/KOER SELF TEST [MZI-3.5]</u></b>.)</p> <ul style="list-style-type: none"> <li>Is the PENDING CODE for the DTC present?</li> </ul>	Yes	Replace the PCM, then go to the next step. (see <b><u>PCM REMOVAL/INSTALLATION [MZI-3.5]</u></b> .)
		No	Go to the next step.
6	<b>VERIFY AFTER REPAIR PROCEDURE</b>	Yes	Go to the applicable DTC inspection. (See <b><u>DTC TABLE [MZI-3.5]</u></b> .)

## 2007 Mazda CX-9 Grand Touring

2007 ENGINE PERFORMANCE On-Board Diagnostic (MZI-3.5) - CX-9

<ul style="list-style-type: none"> <li>• Perform the "AFTER REPAIR PROCEDURE".</li>   <li>(See <b><u>AFTER REPAIR PROCEDURE [MZI-3.5].</u></b>)</li>   <li>• Are any DTCs present?</li> </ul>	No	Troubleshooting completed.
---	----	----------------------------

### DTC P0461 [MZI-3.5]

#### DTC P0461 (MZI-3.5) DETECTION CONDITION AND POSSIBLE CAUSES

<b>DTC P0461</b>	<b>Fuel gauge sender unit range/performance problem</b>
<b>DETECTION CONDITION</b>	<ul style="list-style-type: none"> <li>• The PCM monitors the fuel level input communications network message for a concern. The test fails when the fuel level input signal repeatedly moves in and out of range, exceeding the minimum or maximum allowable calibrated parameters for a specified fuel fill percentage in the fuel tank.</li> </ul>
<b>POSSIBLE CAUSE</b>	<ul style="list-style-type: none"> <li>• Excessive electrical noise</li> <li>• Fuel level input signal circuit malfunction</li> </ul>

#### DIAGNOSTIC PROCEDURE

##### DTC P0461 (MZI-3.5) DIAGNOSTIC PROCEDURE

STEP	INSPECTION		ACTION
1	<b>VERIFY FREEZE FRAME DATA HAS BEEN RECORDED</b> <ul style="list-style-type: none"> <li>• Has FREEZE FRAME DATA been recorded?</li> </ul>	Yes	Go to the next step.
		No	Record the FREEZE FRAME DATA on the repair order, then go to the next step.
2	<b>VERIFY REPAIR INFORMATION AVAILABILITY</b> <ul style="list-style-type: none"> <li>• Verify related Service Bulletins availability.</li> <li>• Is any related Service Bulletins available?</li> </ul>	Yes	Perform repair or diagnosis according to the available Service Bulletins. If the vehicle is not repaired, go to the next step.
		No	Go to the next step.
3	<b>VERIFY RELATED PENDING CODE OR STORED DTCs</b> <ul style="list-style-type: none"> <li>• Turn the ignition switch off then to the ON position (Engine off).</li> <li>• Verify related pending code or stored DTCs.</li> <li>• Is other DTCs present?</li> </ul>	Yes	Go to the appropriate DTC troubleshooting. (See <b><u>DTC TABLE [MZI-3.5].</u></b> )
		No	Go to the next step.

## 2007 Mazda CX-9 Grand Touring

2007 ENGINE PERFORMANCE On-Board Diagnostic (MZI-3.5) - CX-9

4	<b>VERIFY STORED DTC IN INSTRUMENT CLUSTER</b> <ul style="list-style-type: none"> <li>• Turn the ignition switch off then to the ON position (Engine off).</li> <li>• Verify stored DTCs in instrument cluster.</li> <li>• Is other DTCs present?</li> </ul>	Yes	Go to the appropriate DTC inspection. (see <b><u>DTC TABLE [INSTRUMENT CLUSTER]</u></b> .)
		No	Go to the next step.
5	<b>VERIFY TROUBLESHOOTING OF DTC P0461 HAS BEEN COMPLETED</b> <ul style="list-style-type: none"> <li>• Verify that all disconnected connectors reconnected.</li> <li>• Clear the DTC from the PCM memory using the M-MDS.</li> <li>• Perform the "KOEO/KOER self-test".</li> </ul> <p>(See <b><u>KOEO/KOER SELF TEST [MZI-3.5]</u></b>.)</p> <ul style="list-style-type: none"> <li>• Is the PENDING CODE for the DTC present?</li> </ul>	Yes	Replace the PCM, then go to the next step. (see <b><u>PCM REMOVAL/INSTALLATION [MZI-3.5]</u></b> .)
		No	Go to the next step.
6	<b>VERIFY AFTER REPAIR PROCEDURE</b> <ul style="list-style-type: none"> <li>• Perform the "AFTER REPAIR PROCEDURE".</li> </ul> <p>(See <b><u>AFTER REPAIR PROCEDURE [MZI-3.5]</u></b>.)</p> <ul style="list-style-type: none"> <li>• Are any DTCs present?</li> </ul>	Yes	Go to the applicable DTC inspection. (See <b><u>DTC TABLE [MZI-3.5]</u></b> .)
		No	Troubleshooting completed.

### DTC P0462 [MZI-3.5]

#### DTC P0462 (MZI-3.5) DETECTION CONDITION AND POSSIBLE CAUSES

DTC P0462	Fuel gauge sender unit circuit low input
<b>DETECTION CONDITION</b>	<ul style="list-style-type: none"> <li>• The PCM monitors the fuel level input communications network message for a concern. The test fails if the fuel level input signal is less than the minimum allowable calibrated parameter for a specified fuel-fill percentage in the fuel tank.</li> </ul>
	<ul style="list-style-type: none"> <li>• Empty fuel tank</li> </ul>

## 2007 Mazda CX-9 Grand Touring

2007 ENGINE PERFORMANCE On-Board Diagnostic (MZI-3.5) - CX-9

### POSSIBLE CAUSE

- Fuel pump malfunction
- Incorrectly installed fuel gauge
- Instrument cluster malfunction
- Fuel gauge malfunction
- Fuel level input signal circuit malfunction

### DIAGNOSTIC PROCEDURE

#### DTC P0462 (MZI-3.5) DIAGNOSTIC PROCEDURE

STEP	INSPECTION		ACTION
1	<b>VERIFY FREEZE FRAME DATA HAS BEEN RECORDED</b> <ul style="list-style-type: none"> <li>• Has FREEZE FRAME DATA been recorded?</li> </ul>	Yes	Go to the next step.
		No	Record the FREEZE FRAME DATA on the repair order, then go to the next step.
2	<b>VERIFY REPAIR INFORMATION AVAILABILITY</b> <ul style="list-style-type: none"> <li>• Verify related Service Bulletins availability.</li> <li>• Is any related Service Bulletins available?</li> </ul>	Yes	Perform repair or diagnosis according to the available Service Bulletins. If the vehicle is not repaired, go to the next step.
		No	Go to the next step.
3	<b>VERIFY RELATED PENDING CODE OR STORED DTCs</b> <ul style="list-style-type: none"> <li>• Turn the ignition switch off then to the ON position (Engine off).</li> <li>• Verify related pending code or stored DTCs.</li> <li>• Is other DTCs. present?</li> </ul>	Yes	Go to the appropriate DTC troubleshooting. (See <b><u>DTC TABLE [MZI-3.5]</u></b> .)
		No	Go to the next step.
4	<b>VERIFY STORED DTC IN INSTRUMENT CLUSTER</b> <ul style="list-style-type: none"> <li>• Turn the ignition switch off then to the ON position (Engine off).</li> <li>• Verify stored DTCs in instrument cluster.</li> <li>• Is other DTCs present?</li> </ul>	Yes	Go to the appropriate DTC inspection. (see <b><u>DTC TABLE [INSTRUMENT CLUSTER]</u></b> .)
		No	Go to the next step.
5	<b>VERIFY TROUBLESHOOTING OF DTC P0462 HAS BEEN COMPLETED</b> <ul style="list-style-type: none"> <li>• Verify that all disconnected</li> </ul>	Yes	Replace the PCM, then go to the next step. (see <b><u>PCM REMOVAL/INSTALLATION [MZI-3.5]</u></b> .)

## 2007 Mazda CX-9 Grand Touring

2007 ENGINE PERFORMANCE On-Board Diagnostic (MZI-3.5) - CX-9

	<p>connectors reconnected.</p> <ul style="list-style-type: none"> <li>• Clear the DTC from the PCM memory using the M-MDS.</li> <li>• Perform the "KOE0/KOER self-test".</li> </ul> <p>(See <b><u>KOE0/KOER SELF TEST [MZI-3.5]</u></b>.)</p> <ul style="list-style-type: none"> <li>• Is the PENDING CODE for the DTC present?</li> </ul>	No	Go to the next step.
6	<p><b>VERIFY AFTER REPAIR PROCEDURE</b></p> <ul style="list-style-type: none"> <li>• Perform the "AFTER REPAIR PROCEDURE".</li> </ul> <p>(See <b><u>AFTER REPAIR PROCEDURE [MZI-3.5]</u></b>.)</p> <ul style="list-style-type: none"> <li>• Are any DTCs present?</li> </ul>	Yes	Go to the applicable DTC inspection. (See <b><u>DTC TABLE [MZI-3.5]</u></b> .)
		No	Troubleshooting completed.

### DTC P0463 [MZI-3.5]

#### DTC P0463 (MZI-3.5) DETECTION CONDITION AND POSSIBLE CAUSES

DTC P0463	Fuel gauge sender unit circuit high input
<b>DETECTION CONDITION</b>	<ul style="list-style-type: none"> <li>• The PCM monitors the fuel level input communications network message for a concern. The test fails if the fuel level input signal is more than the maximum allowable calibrated parameter for a specified fuel-fill percentage in the fuel tank.</li> </ul>
<b>POSSIBLE CAUSE</b>	<ul style="list-style-type: none"> <li>• Fuel pump malfunction</li> <li>• Incorrectly installed fuel gauge</li> <li>• Instrument cluster malfunction</li> <li>• Fuel level input signal circuit malfunction</li> <li>• Overfilled fuel tank</li> <li>• Fuel gauge malfunction</li> </ul>

#### DIAGNOSTIC PROCEDURE

#### DTC P0463 (MZI-3.5) DIAGNOSTIC PROCEDURE

STEP	INSPECTION		ACTION
1	<b>VERIFY FREEZE FRAME DATA HAS BEEN RECORDED</b>	Yes	Go to the next step.



## 2007 Mazda CX-9 Grand Touring

2007 ENGINE PERFORMANCE On-Board Diagnostic (MZI-3.5) - CX-9

	<ul style="list-style-type: none"> <li>• Has FREEZE FRAME DATA been recorded?</li> </ul>	No	Record the FREEZE FRAME DATA on the repair order, then go to the next step.
2	<b>VERIFY REPAIR INFORMATION AVAILABILITY</b> <ul style="list-style-type: none"> <li>• Verify related Service Bulletins availability.</li> <li>• Is any related Service Bulletins available?</li> </ul>	Yes	Perform repair or diagnosis according to the available Service Bulletins. If the vehicle is not repaired, go to the next step.
		No	Go to the next step.
3	<b>VERIFY RELATED PENDING CODE OR STORED DTCs</b> <ul style="list-style-type: none"> <li>• Turn the ignition switch off then to the ON position (Engine off).</li> <li>• Verify related pending code or stored DTCs.</li> <li>• Is other DTCs present?</li> </ul>	Yes	Go to the appropriate DTC troubleshooting. (See <b><u>DTC TABLE [MZI-3.5]</u></b> .)
		No	Go to the next step.
4	<b>VERIFY STORED DTC IN INSTRUMENT CLUSTER</b> <ul style="list-style-type: none"> <li>• Turn the ignition switch off then to the ON position (Engine off).</li> <li>• Verify stored DTCs in instrument cluster.</li> <li>• Is other DTCs present?</li> </ul>	Yes	Go to the appropriate DTC inspection. (see <b><u>DTC TABLE [INSTRUMENT CLUSTER]</u></b> .)
		No	Go to the next step.
5	<b>VERIFY TROUBLESHOOTING OF DTC P0463 HAS BEEN COMPLETED</b> <ul style="list-style-type: none"> <li>• Verify that all disconnected connectors reconnected.</li> <li>• Clear the DTC from the PCM memory using the M-MDS.</li> <li>• Perform the "KOEO/KOER self-test".</li> </ul> <p>(See <b><u>KOEO/KOER SELF TEST [MZI-3 5]</u></b>.)</p> <ul style="list-style-type: none"> <li>• Is the PENDING CODE for the DTC present?</li> </ul>	Yes	Replace the PCM, then go to the next step. (see <b><u>PCM REMOVAL/INSTALLATION [MZI-3.5]</u></b> .)
		No	Go to the next step.
6	<b>VERIFY AFTER REPAIR PROCEDURE</b>	Yes	Go to the applicable DTC inspection. (See <b><u>DTC TABLE [MZI-3.5]</u></b> .)

## 2007 Mazda CX-9 Grand Touring

2007 ENGINE PERFORMANCE On-Board Diagnostic (MZI-3.5) - CX-9

<ul style="list-style-type: none"> <li>• Perform the "AFTER REPAIR PROCEDURE".</li>   <li>(See <b><u>AFTER REPAIR PROCEDURE [MZI-3.5].</u></b>)</li>   <li>• Are any DTCs present?</li> </ul>	No	Troubleshooting completed.
---	----	----------------------------

### DTC P0480 [MZI-3.5]

#### DTC P0480 (MZI-3.5) DETECTION CONDITION AND POSSIBLE CAUSES

DTC P0480	Fan control circuit
<b>DETECTION CONDITION</b>	<ul style="list-style-type: none"> <li>• This test inspect the fan control circuit. The DTC sets if the PCM detects the voltage of the fan control variable circuit is not within the expected range.</li> </ul>
<b>POSSIBLE CAUSE</b>	<ul style="list-style-type: none"> <li>• Connector or terminal malfunction</li> <li>• Fan control module malfunction</li> </ul> <p style="margin-left: 20px;"><b>Dual fan control module</b></p> <ul style="list-style-type: none"> <li>○ Open Circuit between fan control module No.1 terminal 1B and PCM terminal 1AM</li> <li>○ Short to power supply between fan control module No.1 terminal 1B and PCM terminal 1AM</li> <li>○ Short to ground circuit between fan control module No.1 terminal 1 B and PCM terminal 1AM</li> <li>○ Open circuit between fan control module No.2 terminal B and PCM terminal 1AM</li> <li>○ Short to power supply between fan control module No.2 terminal B and PCM terminal 1AM</li> <li>○ Short to ground circuit between fan control module No.2 terminal B and PCM terminal 1AM</li> <li>○ Open circuit between fan control module No.1 terminal 1 A and cooling fan relay No.1 terminal E</li> <li>○ Open circuit between fan control module No.1 terminal 1C and body ground</li> <li>○ Open circuit between fan control module No.2 terminal A and cooling fan relay No.2 terminal E</li> <li>○ Open circuit between fan control module No.2 terminal C and body ground</li> </ul> <p style="margin-left: 20px;"><b>Single fan control module</b></p> <ul style="list-style-type: none"> <li>○ Open circuit between fan control module terminal 1B and PCM terminal 1A</li> <li>○ Short to power supply between fan control module terminal 1B and PCM</li> </ul>



**2007 Mazda CX-9 Grand Touring**

2007 ENGINE PERFORMANCE On-Board Diagnostic (MZI-3.5) - CX-9

**DIAGNOSTIC PROCEDURE****DTC P0480 (MZI-3.5) DIAGNOSTIC PROCEDURE**

<b>STEP</b>	<b>INSPECTION</b>	<b>ACTION</b>	
1	<b>VERIFY FREEZE FRAME DATA HAS BEEN RECORDED</b> <ul style="list-style-type: none"> <li>Has FREEZE FRAME DATA been recorded?</li> </ul>	Yes	Go to the next step.
		No	Record FREEZE FRAME DATA on the repair order, then go to the next step.
2	<b>VERIFY RELATED REPAIR INFORMATION AVAILABILITY</b> <ul style="list-style-type: none"> <li>Verify related Service Bulletins and/or on-line repair information availability.</li> <li>Is any related Service Bulletins available?</li> </ul>	Yes	Perform repair or diagnosis according to the available Service Bulletins. <ul style="list-style-type: none"> <li>If the vehicle is not repaired, go to the next step.</li> </ul>
		No	Go to the next step.
3	<b>INSPECT FAN CONTROL MODULE CONNECTOR FOR POOR CONNECTION</b> <ul style="list-style-type: none"> <li>Turn the ignition switch off.</li> <li>Disconnect fan control module connector.</li> <li>Inspect for poor connection (such as damaged, pulled-out pins, corrosion, etc.).</li> <li>Are there any malfunction?</li> </ul>	Yes	Repair or replace suspected part, then go to Step 10.
		No	Go to the next step.
4	<b>INSPECT FAN CONTROL MODULE POWER SUPPLY CIRCUIT FOR OPEN CIRCUIT</b> <ul style="list-style-type: none"> <li>Turn the ignition switch to the ON position (Engine off).</li> </ul>	Yes	Go to the next step.

## 2007 Mazda CX-9 Grand Touring

2007 ENGINE PERFORMANCE On-Board Diagnostic (MZI-3.5) - CX-9

	<ul style="list-style-type: none"> <li>• Measure voltage between the following circuits:</li> </ul> <p><b>Dual fan control module</b></p> <ul style="list-style-type: none"> <li>○ Fan control module No.1 terminal 1A (wiring harness-side) and body ground.</li> <li>○ Fan control module No.2 terminal A (wiring harness-side) and body ground.</li> </ul> <p><b>Single fan Control module</b></p> <ul style="list-style-type: none"> <li>○ Fan control module terminal 1C (wiring harness-side) and body ground.</li> </ul> <ul style="list-style-type: none"> <li>• Are there voltage <b>B+</b> ?</li> </ul>	No	Repair or replace suspected part, then go to Step 10.
5	<p><b>INSPECT FAN CONTROL MODULE GROUND CIRCUIT FOR OPEN CIRCUIT</b></p> <ul style="list-style-type: none"> <li>• Turn the ignition switch off.</li> <li>• inspect for continuity between the following circuits:</li> </ul> <p><b>Dual fan control module</b></p> <ul style="list-style-type: none"> <li>○ Fan control module No.1 terminal 1C (wiring harness-side) and body ground.</li> <li>○ Fan control module No.2 terminal C (wiring harness-side) and body ground.</li> </ul> <p><b>Single fan control module</b></p> <ul style="list-style-type: none"> <li>○ Fan control module terminal 1A (wiring harness-side) and body ground.</li> </ul> <ul style="list-style-type: none"> <li>• Are there continuity?</li> </ul>	Yes	Go to the next step.
		No	Repair or replace suspected part, then go to Step 10.
6	<p><b>INSPECT FAN CONTROL CIRCUIT FOR SHORT TO POWER</b></p>	Yes	Repair or replace suspected part, then go to Step 10.

## 2007 Mazda CX-9 Grand Touring

2007 ENGINE PERFORMANCE On-Board Diagnostic (MZI-3.5) - CX-9

	<ul style="list-style-type: none"> <li>• Turn the ignition switch to the ON position (Engine off).</li> <li>• Measure the voltage between the following circuits:</li> </ul> <p><b>Dual fan control module</b></p> <ul style="list-style-type: none"> <li>○ Fan control module No. 1 terminal 1 B (wiring harness-side) and body ground.</li> <li>○ Fan control module No.2 terminal B (wiring harness-side) and body ground.</li> </ul> <p><b>Single fan control module</b></p> <ul style="list-style-type: none"> <li>○ Fan control module terminal 1 B (wiring harness-side) and body ground.</li> </ul> <ul style="list-style-type: none"> <li>• Are there voltage <b>B+</b> ?</li> </ul>	No	Go to the next step.
7	<p><b>INSPECT FAN CONTROL CIRCUIT FOR SHORT TO GROUND</b></p> <ul style="list-style-type: none"> <li>• Turn the ignition switch off.</li> <li>• Inspect continuity between the following circuits:</li> </ul> <p><b>Dual fan control module</b></p> <ul style="list-style-type: none"> <li>○ Fan control module No.1 terminal 1 B (wiring harness-side) and body ground.</li> </ul> <ul style="list-style-type: none"> <li>• Fan control module No.2 terminal B (wiring harness-side) and body ground.</li> </ul> <p><b>Single fan control module</b></p> <ul style="list-style-type: none"> <li>○ Fan control module terminal 1 B (wiring harness-side) and body ground.</li> </ul> <ul style="list-style-type: none"> <li>• Are there continuity?</li> </ul>	Yes	Repair or replace suspected part, then go to Step 10.
		No	Go to the next step.

## 2007 Mazda CX-9 Grand Touring

2007 ENGINE PERFORMANCE On-Board Diagnostic (MZI-3.5) - CX-9

8	<p><b>INSPECT PCM CONNECTOR FOR POOR CONNECTION</b></p> <ul style="list-style-type: none"> <li>• Turn the ignition switch off.</li> <li>• Disconnect PCM connector.</li> <li>• Inspect for poor connection (such as damaged/pulled-out pins, corrosion).</li> <li>• Is there any malfunction?</li> </ul>	Yes	Repair or replace suspected part, then go to Step 10.
		No	Go to the next step.
9	<p><b>INSPECT FAN CONTROL CIRCUIT FOR OPEN CIRCUIT</b></p> <ul style="list-style-type: none"> <li>• Inspect continuity between the following circuits:</li> </ul> <p style="margin-left: 20px;"><b>Dual fan control module</b></p> <ul style="list-style-type: none"> <li>○ Fan control module No.1 terminal 1B (wiring harness-side) and PCM terminal 1AM (wiring harness-side).</li> <li>○ Fan control module No.2 terminal B (wiring harness-side) and PCM terminal 1AM (wiring harness-side).</li> </ul> <p style="margin-left: 20px;"><b>Single fan control module</b></p> <ul style="list-style-type: none"> <li>○ Fan control module terminal 1B (wiring harness-side) and PCM terminal 1AM (wiring harness-side).</li> </ul> <ul style="list-style-type: none"> <li>• Are there continuity?</li> </ul>	Yes	Go to the next step.
		No	Repair or replace suspected part, then go to the next step.
10	<p><b>VERIFY TROUBLESHOOTING OF DTC P0480 HAS BEEN COMPLETED</b></p> <ul style="list-style-type: none"> <li>• Verify that all disconnected connectors reconnected.</li> <li>• Clear the DTC from the PCM memory using the M-MDS.</li> <li>• Perform the "KOEO or KOER self-test".</li> </ul>	Yes	Replace the PCM, then go to the next step. (see <b><u>PCM REMOVAL/INSTALLATION [MZI-3.5]</u></b> .)

## 2007 Mazda CX-9 Grand Touring

2007 ENGINE PERFORMANCE On-Board Diagnostic (MZI-3.5) - CX-9

	(See <b>KOEO/KOER SELF TEST [MZI-3.5].</b> )	No	Go to the next step.
	<ul style="list-style-type: none"> <li>Are any DTCs present?</li> </ul>		
11	<b>VERIFY AFTER REPAIR PROCEDURE</b>	Yes	Go to the applicable DTC inspection. (See <b>DTC TABLE [MZI-3.5].</b> )
	<ul style="list-style-type: none"> <li>Perform the "AFTER REPAIR PROCEDURE".</li> </ul>		
	(See <b>AFTER REPAIR PROCEDURE [MZI-3.5].</b> )	No	Troubleshooting completed.
	<ul style="list-style-type: none"> <li>Are any DTCs present?</li> </ul>		

### DTC P0505 [MZI-3.5]

#### DTC P0505 (MZI-3.5) DETECTION CONDITION AND POSSIBLE CAUSES

<b>DTC P0505</b>	<b>Idle speed control system problem</b>
<b>DETECTION CONDITION</b>	<ul style="list-style-type: none"> <li>The PCM attempts to control engine speed during the KOER self-test. The test fails when the desired engine speed could not be reached or controlled during the self-test.</li> </ul>
<b>POSSIBLE CAUSE</b>	<ul style="list-style-type: none"> <li>Failure mode effects management condition is present</li> <li>Intake air restriction</li> <li>Exhaust restriction</li> <li>Sludged throttle body</li> <li>Vacuum leakage</li> <li>Throttle body malfunction</li> <li>PCM malfunction</li> </ul> <p><b>NOTE:</b></p> <ul style="list-style-type: none"> <li>This DTC is informational only and it may be accompanied by other DTCs. Diagnose other DTCs first. If other DTCs are not present inspect the intake air system for air restrictions, vacuum leaks, and damage. If no concerns are present, clear the DTC and repeat the self-test.</li> </ul>

#### DIAGNOSTIC PROCEDURE

##### DTC P0505 (MZI-3.5) DIAGNOSTIC PROCEDURE

STEP	INSPECTION	ACTION	
1	<b>VERIFY FREEZE FRAME DATA HAS BEEN RECORDED</b>	Yes	Go to the next step.
		No	Record FREEZE FRAME DATA on the



## 2007 Mazda CX-9 Grand Touring

2007 ENGINE PERFORMANCE On-Board Diagnostic (MZI-3.5) - CX-9

	<ul style="list-style-type: none"> <li>Has FREEZE FRAME DATA been recorded?</li> </ul>		repair order, then go to the next step.
2	<b>VERIFY RELATED REPAIR INFORMATION AVAILABILITY</b> <ul style="list-style-type: none"> <li>Verify related Service Bulletins and/or on-line repair information availability.</li> <li>Is any related Service Bulletins available?</li> </ul>	Yes	Perform repair or diagnosis according to the available Service Bulletins. <ul style="list-style-type: none"> <li>If the vehicle is not repaired, go to the next step.</li> </ul>
		No	Go to the next step.
3	<b>VERIFY RELATED PENDING CODE OR STORED DTCs</b> <ul style="list-style-type: none"> <li>Turn the ignition switch off then to the ON position (Engine off).</li> <li>Verify related pending code or stored DTCs.</li> <li>Are other DTCs present?</li> </ul>	Yes	Go to the appropriate DTC troubleshooting. (See <b><u>DTC TABLE [MZI-3.5].</u></b> )
		No	Go to the next step.
4	<b>INSPECT AIR CLEANER ELEMENT</b> <ul style="list-style-type: none"> <li>Remove air cleaner element with the engine running.</li> <li>Is the engine speed increased?</li> </ul>	Yes	Replace the air cleaner element, then go to Step 9.
		No	Go to the next step.
5	<b>INSPECT FOR AIR SUCTION AT INTAKE AIR SYSTEM</b> <ul style="list-style-type: none"> <li>Inspect for air leakage at the following:               <ul style="list-style-type: none"> <li>Around connection of dynamic chamber and intake manifold</li> <li>Around connection of intake manifold and cylinder head</li> </ul> </li> <li>Is air leakage found?</li> </ul>	Yes	Repair or replace the suspected part, then go to Step 9.
		No	Go to the next step.
6	<b>INSPECT THROTTLE BODY PASSAGE</b> <ul style="list-style-type: none"> <li>Is the throttle body clogged?</li> </ul>	Yes	Clean or replace the throttle body passage, then go to Step 9.
		No	Go to the next step.
7	<b>INSPECT ENGINE COMPRESSION</b> <ul style="list-style-type: none"> <li>Inspect the engine compression.</li> </ul> (see <b><u>COMPRESSION</u></b> )	Yes	Go to the next step.
		No	Overhaul the engine, then go to the next step.

## 2007 Mazda CX-9 Grand Touring

2007 ENGINE PERFORMANCE On-Board Diagnostic (MZI-3.5) - CX-9

<u>INSPECTION [MZI-3.5] .)</u>			
	<ul style="list-style-type: none"> <li>• Is the engine compression normal?</li> </ul>		
8	<b>INSPECT FOR RESTRICTION IN EXHAUST SYSTEM AND TWC</b> <ul style="list-style-type: none"> <li>• Is there any restriction?</li> </ul>	Yes	Replace malfunctioning part, then go to the next step.
		No	Go to the next step.
9	<b>VERIFY TROUBLESHOOTING OF DTC P0505 HAS BEEN COMPLETED</b> <ul style="list-style-type: none"> <li>• Verify that all disconnected connectors are reconnected.</li> <li>• Turn the ignition switch to the ON position (Engine off).</li> <li>• Clear the DTC from the PCM memory using the M-MDS.</li> <li>• Perform the KOEO and KOER self-test.</li> <li>• Retrieve the DTCs using the M-MDS.</li> <li>• Is the PENDING CODE for this DTC present?</li> </ul>	Yes	Replace the PCM, then go to the next step. (see <b>PCM REMOVAL/INSTALLATION [MZI-3.5] .)</b>
		No	Go to the next step.
10	<b>VERIFY AFTER REPAIR PROCEDURE</b> <ul style="list-style-type: none"> <li>• Perform the "AFTER REPAIR PROCEDURE".</li> </ul> <p>(See <b>AFTER REPAIR PROCEDURE [MZI-3.5].)</b></p> <ul style="list-style-type: none"> <li>• Are any DTC present?</li> </ul>	Yes	Go to the applicable DTC inspection. (See <b>DTC TABLE [MZI-3.5].)</b>
		No	Troubleshooting completed.

### DTC P0506 [MZI-3.5]

#### DTC P0506 (MZI-3.5) DETECTION CONDITION AND POSSIBLE CAUSES

DTC P0506	IAC system RPM lower than expected
<b>DETECTION CONDITION</b>	<ul style="list-style-type: none"> <li>• This DTC is set when the PCM detects an engine idle speed that is less than the desired engine speed.</li> </ul>
	<ul style="list-style-type: none"> <li>• Engine mechanical concern</li> <li>• Intake air restriction</li> <li>• Exhaust restriction</li> </ul>

## 2007 Mazda CX-9 Grand Touring

2007 ENGINE PERFORMANCE On-Board Diagnostic (MZI-3.5) - CX-9

### POSSIBLE CAUSE

- Sludged throttle body
- Vacuum leakage
- Throttle body malfunction
- PCM malfunction

### DIAGNOSTIC PROCEDURE

#### DTC P0506 (MZI-3.5) DIAGNOSTIC PROCEDURE

STEP	INSPECTION		ACTION
1	<b>VERIFY FREEZE FRAME DATA HAS BEEN RECORDED</b> <ul style="list-style-type: none"> <li>• Has FREEZE FRAME DATA been recorded?</li> </ul>	Yes	Go to the next step.
		No	Record FREEZE FRAME DATA on the to the next step. repair order, then go
2	<b>VERIFY RELATED REPAIR INFORMATION AVAILABILITY</b> <ul style="list-style-type: none"> <li>• Verify related Service Bulletins and/or on-line repair information availability.</li> <li>• Is any related Service Bulletins available?</li> </ul>	Yes	Perform repair or diagnosis according to the available Service Bulletins. <ul style="list-style-type: none"> <li>• If the vehicle is not repaired, then go to the next step.</li> </ul>
		No	Go to the next step.
3	<b>VERIFY RELATED PENDING OR STORED DTCS</b> <ul style="list-style-type: none"> <li>• Turn the ignition switch off then to the ON position (Engine off).</li> <li>• Verify pending code or stored DTCs using the M-MDS.</li> <li>• Is other DTC present?</li> </ul>	Yes	Repair applicable DTCs. (See <b><u>DTC TABLE [MZI-3.5]</u></b> .)
		No	Go to the next step.
4	<b>INSPECT AIR CLEANER ELEMENT</b> <ul style="list-style-type: none"> <li>• Remove air cleaner element with the engine running.</li> <li>• Is the engine speed increased?</li> </ul>	Yes	Replace the air cleaner element, then go to Step 7.
		No	Go to the next step.
5	<b>INSPECT INTAKE AIR SYSTEM FOR EXCESSIVE AIR SUCTION</b> <ul style="list-style-type: none"> <li>• Visually inspect the hose in intake air system for damages.</li> <li>• Is there any malfunction?</li> </ul>	Yes	Repair or replace the malfunctioning part, then go to Step 7.
		No	Go to the next step.
6	<b>INSPECT THROTTLE BODY</b>	Yes	Clean or replace the throttle body passage,

## 2007 Mazda CX-9 Grand Touring

2007 ENGINE PERFORMANCE On-Board Diagnostic (MZI-3.5) - CX-9

	<b>PASSAGE</b>		then go to the next step.
	<ul style="list-style-type: none"> <li>Is the throttle body clogged?</li> </ul>	No	Go to the next step.
7	<b>VERIFY TROUBLESHOOTING OF DTC P0506 HAS BEEN COMPLETED</b> <ul style="list-style-type: none"> <li>Verify that all disconnected connectors reconnected.</li> <li>Start the engine.</li> <li>Clear the DTC from the PCM memory using the M-MDS.</li> <li>Depress brake pedal for <b>14s or more</b> .</li> <li>Is <b>PENDING CODE</b> for this DTC present?</li> </ul>	Yes	Replace the PCM, then go to the next step. (see <b>PCM REMOVAL/INSTALLATION [MZI-3.5]</b> .)
		No	Go to the next step.
8	<b>VERIFY AFTER REPAIR PROCEDURE</b> <ul style="list-style-type: none"> <li>Perform the "AFTER REPAIR PROCEDURE".</li> </ul> <p>(See <b>AFTER REPAIR PROCEDURE [MZI-3.5]</b>.)</p> <ul style="list-style-type: none"> <li>Are any DTCs present?</li> </ul>	Yes	Go to the applicable DTC inspection. (See <b>DTC TABLE [MZI-3.5]</b> .)
		No	Troubleshooting completed.

### DTC P0507 [MZI-3.5]

#### DTC P0507 (MZI-3.5) DETECTION CONDITION AND POSSIBLE CAUSES

<b>DTC P0507</b>	<b>IAC system RPM higher than expected</b>
<b>DETECTION CONDITION</b>	<ul style="list-style-type: none"> <li>This DTC is set when the PCM detects an engine idle speed that is more than the desired engine speed.</li> </ul>
<b>POSSIBLE CAUSE</b>	<ul style="list-style-type: none"> <li>Intake air leak after throttle body</li> <li>Vacuum leakage</li> <li>EVAP system malfunction</li> <li>Throttle body malfunction</li> <li>PCM malfunction</li> </ul>

#### DIAGNOSTIC PROCEDURE

#### DTC P0507 (MZI-3.5) DIAGNOSTIC PROCEDURE

--	--	--

## 2007 Mazda CX-9 Grand Touring

2007 ENGINE PERFORMANCE On-Board Diagnostic (MZI-3.5) - CX-9

STEP	INSPECTION	ACTION	
1	<b>VERIFY FREEZE FRAME DATA HAS BEEN RECORDED</b> <ul style="list-style-type: none"> <li>• Has FREEZE FRAME DATA been recorded?</li> </ul>	Yes	Go to the next step.
		No	Record FREEZE FRAME DATA on the repair order, then go to the next step.
2	<b>VERIFY RELATED REPAIR INFORMATION AVAILABILITY</b> <ul style="list-style-type: none"> <li>• Verify related Service Bulletins and/or on-line repair information availability.</li> <li>• Is any related Service Bulletins available?</li> </ul>	Yes	Perform repair or diagnosis according to the available Service Bulletins. <ul style="list-style-type: none"> <li>• If the vehicle is not repaired, then go to the next step.</li> </ul>
		No	Go to the next step.
3	<b>VERIFY RELATED PENDING OR STORED DTCs</b> <ul style="list-style-type: none"> <li>• Turn the ignition switch off then to the ON position (Engine off).</li> <li>• Verify pending code or stored DTCs using the M-MDS.</li> <li>• Is other DTC present?</li> </ul>	Yes	Repair applicable DTCs. (See <b><u>DTC TABLE [MZI-3.5]</u></b> .)
		No	Go to the next step.
4	<b>INSPECT AIR CLEANER ELEMENT</b> <ul style="list-style-type: none"> <li>• Remove air cleaner element with the engine running.</li> <li>• Is the engine speed increased?</li> </ul>	Yes	Replace the air cleaner element, then go to Step 7.
		No	Go to the next step.
5	<b>INSPECT INTAKE AIR SYSTEM FOR EXCESSIVE AIR SUCTION</b> <ul style="list-style-type: none"> <li>• Visually inspect the hose in intake air system for looseness or damages.</li> <li>• Is there any malfunction?</li> </ul>	Yes	Repair or replace the malfunctioning part, then go to Step 7.
		No	Go to the next step.
6	<b>INSPECT THROTTLE BODY PASSAGE</b> <ul style="list-style-type: none"> <li>• Is the throttle body clogged?</li> </ul>	Yes	Clean or replace the throttle body passage, then go to Step 7.
		No	Go to the next step.
7	<b>VERIFY TROUBLESHOOTING OF DTC P0507 HAS BEEN COMPLETED</b> <ul style="list-style-type: none"> <li>• Verify that all disconnected</li> </ul>	Yes	Replace the PCM, then go to the next step. (see <b><u>PCM REMOVAL/INSTALLATION [MZI-3.5]</u></b> .)

## 2007 Mazda CX-9 Grand Touring

2007 ENGINE PERFORMANCE On-Board Diagnostic (MZI-3.5) - CX-9

	<p>connectors reconnected.</p> <ul style="list-style-type: none"> <li>Start the engine.</li> <li>Clear the DTC from the PCM memory using the M-MDS.</li> <li>Depress brake pedal for <b>14 s or more</b>.</li> <li>Is PENDING CODE for this DTC present?</li> </ul>	No	Go to the next step.
8	<p><b>VERIFY AFTER REPAIR PROCEDURE</b></p> <ul style="list-style-type: none"> <li>Perform the "AFTER REPAIR PROCEDURE".</li> </ul> <p>(See <b>AFTER REPAIR PROCEDURE [MZI-3.5]</b>.)</p> <ul style="list-style-type: none"> <li>Are any DTC present?</li> </ul>	Yes	Go to the applicable DTC inspection. (See <b>DTC TABLE [MZI-3.5]</b> .)
		No	Troubleshooting completed.

### DTC P050E [MZI-3.5]

#### DTC P050E (MZI-3.5) DETECTION CONDITION AND POSSIBLE CAUSES

DTC P050E	Cold start engine exhaust temperature out of range
<b>DETECTION CONDITION</b>	<ul style="list-style-type: none"> <li>The PCM calculates the actual catalyst warm up temperature during a cold start. The PCM then compares the actual temperature to the expected catalyst temperature model. The difference between the actual and expected temperatures is a ratio. When this ratio exceeds the calibrated value this DTC is set and the malfunction indicator lamp (MIL) illuminates.</li> </ul>
<b>POSSIBLE CAUSE</b>	<ul style="list-style-type: none"> <li>Intake air restriction</li> <li>Exhaust restriction</li> <li>Mechanical concern with the engine</li> <li>Throttle body malfunction</li> <li>Vacuum leakage</li> <li>PCM malfunction</li> </ul>

#### DIAGNOSTIC PROCEDURE

##### DTC P050E (MZI-3.5) DIAGNOSTIC PROCEDURE

STEP	INSPECTION	ACTION
1	<p><b>VERIFY FREEZE FRAME DATA HAS BEEN RECORDED</b></p>	<p>Yes: Go to the next step.</p>

## 2007 Mazda CX-9 Grand Touring

2007 ENGINE PERFORMANCE On-Board Diagnostic (MZI-3.5) - CX-9

	<ul style="list-style-type: none"> <li>• Has FREEZE FRAME DATA been recorded?</li> </ul>	No	Record FREEZE FRAME DATA on the repair order, then go to the next step.
2	<b>VERIFY RELATED REPAIR INFORMATION AVAILABILITY</b> <ul style="list-style-type: none"> <li>• Verify related Service Bulletins and/or on-line repair information availability.</li> <li>• Is any related Service Bulletins available?</li> </ul>	Yes	Perform repair or diagnosis according to the available Service Bulletins. <ul style="list-style-type: none"> <li>• If the vehicle is not repaired, go to the next step.</li> </ul>
		No	Go to the next step.
3	<b>VERIFY RELATED PENDING CODE OR STORED DTCs</b> <ul style="list-style-type: none"> <li>• Turn the ignition switch off then to the ON position (Engine off).</li> <li>• Verify related pending code or stored DTCs.</li> <li>• Is other DTCs present?</li> </ul>	Yes	Go to the appropriate DTC troubleshooting. (See <b><u>DTC TABLE [MZI-3.5].</u></b> )
		No	Go to the next step.
4	<b>INSPECT AIR CLEANER ELEMENT</b> <ul style="list-style-type: none"> <li>• Remove air cleaner element with the engine running.</li> <li>• Is the engine speed increased?</li> </ul>	Yes	Replace the air cleaner element, then go to Step 9.
		No	Go to the next step.
5	<b>INSPECT INTAKE AIR SYSTEM FOR EXCESSIVE AIR SUCTION</b> <ul style="list-style-type: none"> <li>• Visually inspect the hose in intake air system for looseness or damages.</li> <li>• Is there any malfunction?</li> </ul>	Yes	Repair or replace the malfunctioning part, then go to Step 9.
		No	Go to the next step.
6	<b>INSPECT THROTTLE BODY PASSAGE</b> <ul style="list-style-type: none"> <li>• Is the throttle body clogged?</li> </ul>	Yes	Clean or replace the throttle body passage, then go to Step 9.
		No	Go to the next step.
7	<b>INSPECT ENGINE COMPRESSION</b> <ul style="list-style-type: none"> <li>• Inspect the engine compression.</li> </ul> (see <b><u>COMPRESSION INSPECTION [MZI-3.5]</u></b> .) <ul style="list-style-type: none"> <li>• Is the engine compression normal?</li> </ul>	Yes	Go to the next step.
		No	Overhaul the engine, then go to Step 9.
8	<b>INSPECT FOR RESTRICTION IN</b>	Yes	Replace malfunctioning part, then go to

## 2007 Mazda CX-9 Grand Touring

2007 ENGINE PERFORMANCE On-Board Diagnostic (MZI-3.5) - CX-9

	<b>EXHAUST SYSTEM AND TWC</b> <ul style="list-style-type: none"> <li>• Is there any restriction?</li> </ul>	No	the next step. Go to the next step.
9	<b>VERIFY TROUBLESHOOTING OF DTC P050E HAS BEEN COMPLETED</b> <ul style="list-style-type: none"> <li>• Verify that all disconnected connectors are reconnected.</li> <li>• Turn the ignition switch to the ON position (Engine off).</li> <li>• Clear the DTC from the PCM memory using the M-MDS.</li> <li>• Perform the "KOEO and KOER self-test".</li> </ul> <p>(See <b>KOEO/KOER SELF TEST [MZI-3.5]</b>.)</p> <ul style="list-style-type: none"> <li>• Retrieve DTCs using the M-MDS.</li> <li>• Is the PENDING CODE for this DTC present?</li> </ul>	Yes	Replace the PCM, then go to the next step. (see <b>PCM REMOVAL/INSTALLATION [MZI-3.5]</b> .)
		No	Go to the next step.
10	<b>VERIFY AFTER REPAIR PROCEDURE</b> <ul style="list-style-type: none"> <li>• Perform the "AFTER REPAIR PROCEDURE".</li> </ul> <p>(See <b>AFTER REPAIR PROCEDURE [MZI-3.5]</b>.)</p> <ul style="list-style-type: none"> <li>• Are any DTCs present?</li> </ul>	Yes	Go to the applicable DTC inspection. (See <b>DTC TABLE [MZI-3.5]</b> .)
		No	Troubleshooting completed.

### DTC P053A [MZI-3.5]

#### DTC P053A (MZI-3.5) DETECTION CONDITION AND POSSIBLE CAUSES

<b>DTC P053A</b>	<b>PCV valve heater control circuit/open</b>
<b>DETECTION CONDITION</b>	<ul style="list-style-type: none"> <li>• This DTC is set when the PCM detects a PCV valve heater circuit malfunction.</li> </ul>
	<ul style="list-style-type: none"> <li>• Open circuit between PCV valve heater control terminal A and main relay No.1</li> <li>• Open circuit between PCV valve heater fitting terminal A and main relay No.1</li> <li>• Short to ground circuit between PCV valve heater control terminal B and PCM terminal 2BL</li> </ul>



## 2007 Mazda CX-9 Grand Touring

2007 ENGINE PERFORMANCE On-Board Diagnostic (MZI-3.5) - CX-9

### POSSIBLE CAUSE

- Short to ground circuit between PCV valve heater fitting terminal B and PCM terminal 2AU
- Short to power circuit between PCV valve heater control terminal B and PCM terminal 2BL
- Short to power circuit between PCV valve heater fitting terminal B and PCM terminal 2AU
- Open circuit between PCV valve heater control terminal B and PCM terminal 2BI
- Open circuit between PCV valve heater fitting B and PCM terminal 2AU
- Connector or terminal malfunction
- Damaged PCV heater assembly

# 2007 Mazda CX-9 Grand Touring

2007 ENGINE PERFORMANCE On-Board Diagnostic (MZI-3.5) - CX-9

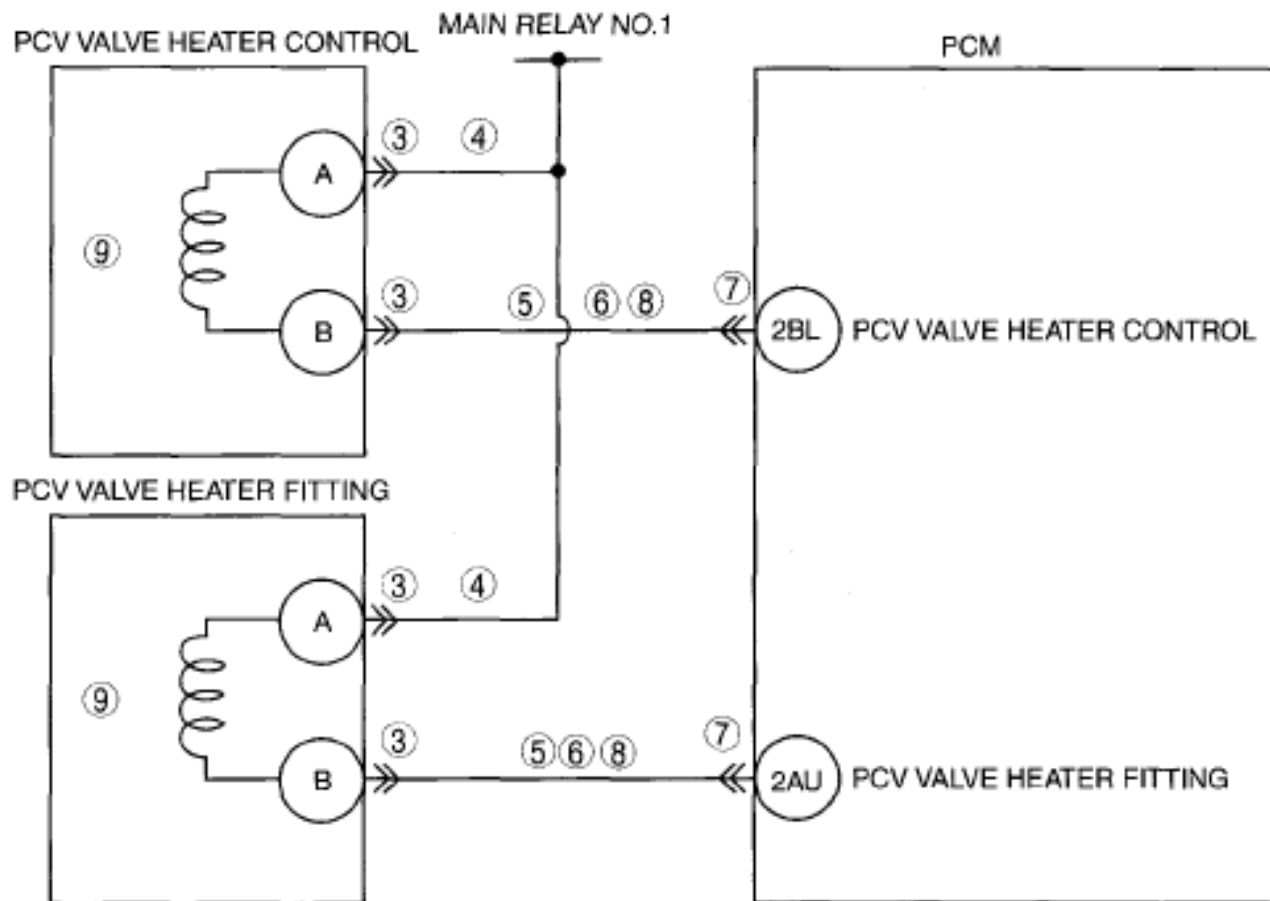

PCV VALVE HEATER CONTROL WIRING HARNESS-SIDE CONNECTOR



PCM WIRING HARNESS-SIDE CONNECTOR

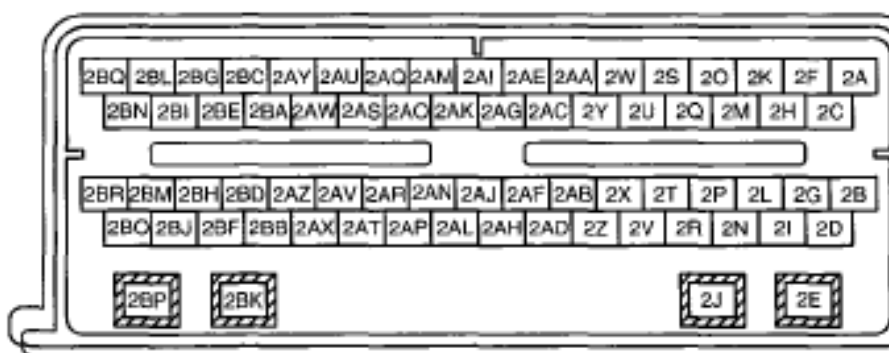

PCV VALVE HEATER FITTING WIRING HARNESS-SIDE CONNECTOR

## 2007 Mazda CX-9 Grand Touring

2007 ENGINE PERFORMANCE On-Board Diagnostic (MZI-3.5) - CX-9

### DIAGNOSTIC PROCEDURE

#### DTC P053A (MZI-3.5) DIAGNOSTIC PROCEDURE

STEP	INSPECTION	ACTION	
1	<b>VERIFY FREEZE FRAME DATA HAS BEEN RECORDED</b> <ul style="list-style-type: none"> <li>• Has FREEZE FRAME DATA been recorded</li> </ul>	yes	go to the next step.
		No	Record FREEZE FRAME DATA on the repair order, then go to the next step.
2	<b>VERIFY RELATED REPAIR INFORMATION AVAILABILITY</b> <ul style="list-style-type: none"> <li>• Verify related Service Bulletins and/or on-line repair information availability.</li> <li>• Is any related Service Bulletins available?</li> </ul>	Yes	Perform repair or diagnosis according to the available Service Bulletins. <ul style="list-style-type: none"> <li>• If the vehicle is not repaired, go to the next step.</li> </ul>
		No	Go to the next step.
3	<b>INSPECT PCV VALVE HEATER CONTROL AND PCV VALVE HEATER FITTING CONNECTOR FOR POOR CONNECTION</b> <ul style="list-style-type: none"> <li>• Turn the ignition switch off.</li> <li>• Disconnect PCV valve heater control and PCV valve heater fitting connector.</li> <li>• Inspect for poor connection (such as damaged/pulled-out pins, corrosion).</li> <li>• Are there any malfunction?</li> </ul>	Yes	Repair or replace suspected part, then go to Step 10.
		No	Go to the next step.
4	<b>INSPECT POWER SUPPLY CIRCUIT FOR OPEN CIRCUIT</b> <ul style="list-style-type: none"> <li>• Turn the ignition switch to the ON position (Engine off).</li> <li>• Inspect the voltage between the following circuit:                             <ul style="list-style-type: none"> <li>○ PCV valve heater control terminal A (wiring harness-side) and body ground</li> <li>○ PCV valve heater fitting terminal A (wiring harness-side) and body ground</li> </ul> </li> <li>• Are there voltage B+?</li> </ul>	Yes	Go to the next step.
		No	Repair or replace suspected part, then go to Step 10.

## 2007 Mazda CX-9 Grand Touring

2007 ENGINE PERFORMANCE On-Board Diagnostic (MZI-3.5) - CX-9

5	<p><b>INSPECT PCV VALVE HEATER CONTROL AND PCV VALVE HEATER FITTING CIRCUIT FOR SHORT TO POWER SUPPLY</b></p> <ul style="list-style-type: none"> <li>• Turn the ignition switch to the ON position (Engine off).</li> <li>• Inspect for continuity between the following circuit:                             <ul style="list-style-type: none"> <li>○ PCV valve heater control terminal B (wiring harness-side) and body ground</li> <li>○ PCV valve heater fitting terminal B (wiring harness-side) and body ground</li> </ul> </li> <li>• Are there voltage B+?</li> </ul>	Yes	Repair or replace suspected part, then go to Step 10.
		No	Go to the next step.
6	<p><b>INSPECT PCV VALVE HEATER CONTROL AND PCV VALVE HEATER FITTING CIRCUIT FOR SHORT TO GROUND</b></p> <ul style="list-style-type: none"> <li>• Inspect for continuity between the following circuit:                             <ul style="list-style-type: none"> <li>○ PCV valve heater control terminal B (wiring harness-side) and body ground</li> <li>○ PCV valve heater fitting terminal B (wiring harness-side) and body ground</li> </ul> </li> <li>• Are there continuity?</li> </ul>	Yes	Repair or replace suspected part, then go to Step 10.
		No	Go to the next step.
7	<p><b>INSPECT PCM CONNECTOR FOR POOR CONNECTION</b></p> <ul style="list-style-type: none"> <li>• Turn the ignition switch off.</li> <li>• Disconnect PCM connector.</li> <li>• Inspect for poor connection (such as damaged/pulled-out pins, corrosion).</li> <li>• Are there any malfunction?</li> </ul>	Yes	Repair or replace suspected part, then go to Step 10.
		No	Go to the next step.
8	<p><b>INSPECT PCV VALVE HEATER CONTROL AND PCV VALVE HEATER FITTING FOR OPEN CIRCUIT</b></p>	Yes	Go to the next step.

## 2007 Mazda CX-9 Grand Touring

2007 ENGINE PERFORMANCE On-Board Diagnostic (MZI-3.5) - CX-9

	<ul style="list-style-type: none"> <li>• Inspect for continuity between the following circuit:             <ul style="list-style-type: none"> <li>○ PCV valve heater control terminal B (wiring harness-side) and PCM terminal 2BL (wiring harness-side)</li> <li>○ PCV valve heater fitting B (wiring harness-side) and PCM terminal 2AU (wiring harness-side)</li> </ul> </li> <li>• Are there continuity?</li> </ul>	No	Repair or replace suspected part, then go to Step 10.
9	<p><b>INSPECT PCV VALVE HEATER CONTROL AND PCV VALVE HEATER FITTING</b></p> <ul style="list-style-type: none"> <li>• Inspect the PCV valve heater control and PCV valve heater fitting.</li> </ul> <p>(see <b><u>POSITIVE CRANKCASE VENTILATION (PCV) VALVE INSPECTION [MZI-3.5].</u></b> )</p> <p>(see <b><u>POSITIVE CRANKCASE VENTILATION (PCV) VALVE HEATER FITTING INSPECTION [MZI-3.5].</u></b> )</p> <ul style="list-style-type: none"> <li>• Is there any malfunction?</li> </ul>	Yes	Replace the malfunctioning part, then go to the next step.
		No	Go to the next step.
10	<p><b>VERIFY TROUBLESHOOTING OF DTC P053A HAS BEEN COMPLETED</b></p> <ul style="list-style-type: none"> <li>• Verify that all disconnected connectors reconnected.</li> <li>• Clear the DTC from the PCM memory using the M-MDS.</li> <li>• Perform the "KOEO or KOER self-test" using the M-MDS.</li> </ul> <p>(See <b><u>KOEO/KOER SELF TEST [MZI-3.5].</u></b>)</p> <ul style="list-style-type: none"> <li>• Is the PENDING CODE for the DTC present?</li> </ul>	Yes	Replace the PCM, then go to the next step. (see <b><u>PCM REMOVAL/INSTALLATION [MZI-3.5].</u></b> )
		No	Go to the next step.

## 2007 Mazda CX-9 Grand Touring

2007 ENGINE PERFORMANCE On-Board Diagnostic (MZI-3.5) - CX-9

11	<b>VERIFY AFTER REPAIR PROCEDURE</b> <ul style="list-style-type: none"> <li>• Perform the "AFTER REPAIR PROCEDURE".</li> </ul> <p>(See <b><u>AFTER REPAIR PROCEDURE [MZI-3.5]</u></b>.)</p> <ul style="list-style-type: none"> <li>• Are any DTCs present?</li> </ul>	Yes	Go to the applicable DTC inspection. (See <b><u>DTC TABLE [MZI-3.5]</u></b> .)
		No	Troubleshooting completed.

### DTC P0579 [MZI-3.5]

#### DTC P0579 (MZI-3.5) DETECTION CONDITION AND POSSIBLE CAUSES

DTC P0579	Cruise control multi-function input circuit range/performance
<b>DETECTION CONDITION</b>	<ul style="list-style-type: none"> <li>• P0579 may set when the cruise control switch circuits are open, shorted to voltage ground.</li> </ul>
<b>POSSIBLE CAUSE</b>	<ul style="list-style-type: none"> <li>• Connector or terminal malfunction</li> <li>• Open circuit between cruise control switch terminal B and PCM terminal 1AT</li> <li>• Open circuit between cruise control switch terminal C and PCM terminal 1AP</li> <li>• Short to power supply between cruise control switch terminal B and PCM terminal 1AT</li> <li>• Short to power supply between cruise control switch terminal C and PCM terminal 1AP</li> <li>• Short to ground circuit between cruise control switch terminal B and PCM terminal 1AT</li> <li>• Short to ground circuit between cruise control switch terminal C and PCM terminal 1AP</li> <li>• Cruise control switch malfunction</li> <li>• PCM malfunction</li> </ul>

## 2007 Mazda CX-9 Grand Touring

2007 ENGINE PERFORMANCE On-Board Diagnostic (MZI-3.5) - CX-9

### CRUISE CONTROL SWITCH

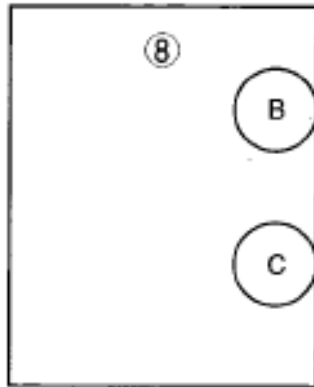

### PCM

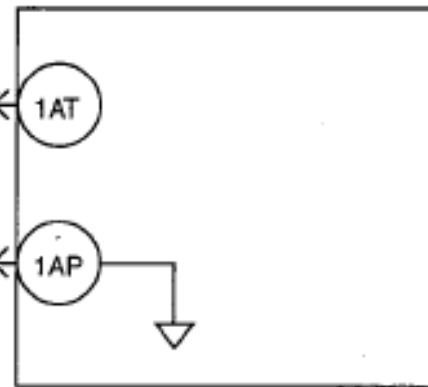

### PCM WIRING HARNESS-SIDE CONNECTOR

### CRUISE CONTROL SWITCH WIRING HARNESS-SIDE CONNECTOR

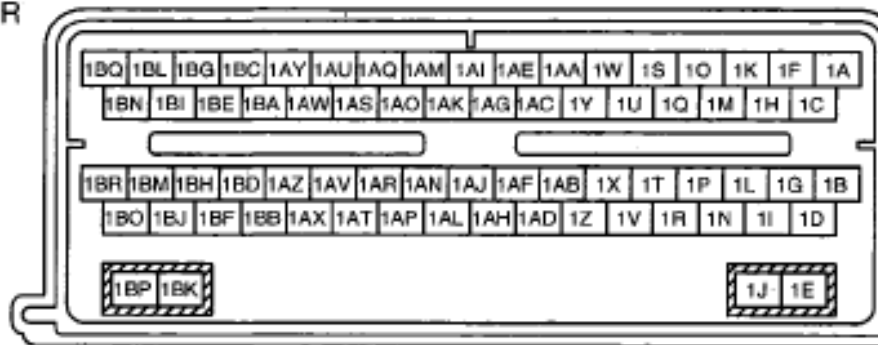

## DIAGNOSTIC PROCEDURE

### DTC P0579 (MZI-3.5) DIAGNOSTIC PROCEDURE

STEP	INSPECTION		ACTION
1	<b>VERIFY FREEZE FRAME DATA HAS BEEN RECORDED</b> <ul style="list-style-type: none"> <li>Has FREEZE FRAME DATA been recorded?</li> </ul>	Yes	Go to the next step.
		No	Record FREEZE FRAME DATA on the repair order, then go to the next step.
2	<b>VERIFY RELATED REPAIR INFORMATION AVAILABILITY</b> <ul style="list-style-type: none"> <li>Verify related Service Bulletins and/or on-line repair information</li> </ul>	Yes	Perform repair or diagnosis according to the available Service Bulletins. <ul style="list-style-type: none"> <li>If the vehicle is not repaired, go to the next step.</li> </ul>

## 2007 Mazda CX-9 Grand Touring

2007 ENGINE PERFORMANCE On-Board Diagnostic (MZI-3.5) - CX-9

	<p>availability.</p> <ul style="list-style-type: none"> <li>• Is any related Service Bulletins available?</li> </ul>	No	Go to the next step.
3	<p><b>INSPECT CRUISE CONTROL SWITCH CONNECTOR FOR POOR CONNECTION</b></p> <ul style="list-style-type: none"> <li>• Turn the ignition switch to off.</li> <li>• Disconnect the cruise control switch connector.</li> <li>• Inspect for poor connection (such as damaged/pulled-out pins, corrosion).</li> <li>• Are there any malfunction?</li> </ul>	Yes	Repair or replace suspected part, then go to Step 9.
		No	Go to the next step.
4	<p><b>INSPECT CRUISE CONTROL SWITCH CIRCUIT FOR SHORT TO POWER SUPPLY</b></p> <ul style="list-style-type: none"> <li>• Turn the ignition switch to the ON position (Engine off).</li> <li>• Measure the voltage between the following terminals: <ul style="list-style-type: none"> <li>○ Cruise control switch terminal B and body ground</li> <li>○ Cruise control switch terminal C and body ground</li> </ul> </li> <li>• Are there voltage B+?</li> </ul>	Yes	Repair or replace suspected part, then go to Step 9.
		No	Go to the next step.
5	<p><b>INSPECT CRUISE CONTROL SWITCH CIRCUIT FOR SHORT TO GROUND</b></p> <ul style="list-style-type: none"> <li>• Turn the ignition switch off.</li> <li>• Inspect for continuity between the following terminals: <ul style="list-style-type: none"> <li>○ Cruise control switch terminal B and body ground</li> <li>○ Cruise control switch terminal C and body ground</li> </ul> </li> <li>• Are there continuity?</li> </ul>	Yes	Repair or replace suspected part, then go to Step 9.
		No	Go to the next step.
6	<p><b>INSPECT PCM CONNECTOR FOR POOR CONNECTION</b></p> <ul style="list-style-type: none"> <li>• Turn the ignition switch off.</li> </ul>	Yes	Repair or replace suspected part, then go to Step 9.



## 2007 Mazda CX-9 Grand Touring

2007 ENGINE PERFORMANCE On-Board Diagnostic (MZI-3.5) - CX-9

	<ul style="list-style-type: none"> <li>• Disconnect the PCM connector.</li> <li>• Inspect for poor connection (such as damaged/pulled-out pins, corrosion).</li> <li>• Are there any malfunction?</li> </ul>	No	Go to the next Step.
7	<b>INSPECT CRUISE CONTROL SWITCH CIRCUIT FOR OPEN</b> <ul style="list-style-type: none"> <li>• Disconnect the PCM connector.</li> <li>• Inspect for continuity between the following terminals:                             <ul style="list-style-type: none"> <li>○ Cruise control switch terminal B and PCM terminal 1AT</li> <li>○ Cruise control switch terminal C and PCM terminal 1AP</li> </ul> </li> <li>• Are there continuity?</li> </ul>	Yes	Go to the next step.
		No	Repair or replace suspected part, then go to Step 9.
8	<b>INSPECT CRUISE CONTROL SWITCH</b> <ul style="list-style-type: none"> <li>• Inspect the cruise control switch.</li> </ul> <p>(see <b><u>CRUISE CONTROL SWITCH INSPECTION [MZI-3.5]</u></b> .)</p> <ul style="list-style-type: none"> <li>• Is there malfunction?</li> </ul>	Yes	Replace the cruise control switch, then go to the next step.
		No	Go to the next step.
9	<b>VERIFY TROUBLESHOOTING OF DTC P0579 HAS BEEN COMPLETED</b> <ul style="list-style-type: none"> <li>• Verify that all disconnected connectors are reconnected.</li> <li>• Turn the ignition switch to the ON position (Engine off).</li> <li>• Clear the DTC from the PCM memory using the M-MDS.</li> <li>• Perform the "KOEO and KOER self-test".</li> </ul> <p>(See <b><u>KOEO/KOER SELF TEST [MZI-3.5]</u></b>.)</p>	Yes	Replace the PCM, then go to the next step. (see <b><u>PCM REMOVAL/INSTALLATION [MZI-3.5]</u></b> .)
		No	Go to the next step.

## 2007 Mazda CX-9 Grand Touring

2007 ENGINE PERFORMANCE On-Board Diagnostic (MZI-3.5) - CX-9

	<ul style="list-style-type: none"> <li>Retrieve DTCs using the M-MDS.</li> <li>Is the PENDING CODE for this DTC present?</li> </ul>		
10	<p><b>VERIFY AFTER REPAIR PROCEDURE</b></p> <ul style="list-style-type: none"> <li>Perform the "AFTER REPAIR PROCEDURE".</li> </ul> <p>(See <b><u>AFTER REPAIR PROCEDURE [MZI-3.5].</u></b>)</p> <ul style="list-style-type: none"> <li>Are any DTCs present?</li> </ul>	Yes	Go to the applicable DTC inspection. (See <b><u>DTC TABLE [MZI-3.5].</u></b> )
		No	Troubleshooting completed.

### DTC P0581 [MZI-3.5]

#### DTC P0581 (MZI-3.5) DETECTION CONDITION AND POSSIBLE CAUSES

<b>DTC P0581</b>	<b>Cruise control multi-function input circuit high</b>
<b>DETECTION CONDITION</b>	<ul style="list-style-type: none"> <li>P0581 sets when the cruise control switch circuits are shorted to voltage or open.</li> </ul>
<b>POSSIBLE CAUSE</b>	<ul style="list-style-type: none"> <li>Connector or terminal malfunction</li> <li>Open circuit between cruise control switch terminal B and PCM terminal 1AT</li> <li>Open circuit between cruise control switch terminal C and PCM terminal 1AP</li> <li>Short to power supply between cruise control switch terminal B and PCM terminal AT</li> <li>Short to power supply between cruise control switch terminal C and PCM terminal AP</li> <li>Cruise control switch malfunction</li> <li>PCM malfunction</li> </ul>

## 2007 Mazda CX-9 Grand Touring

2007 ENGINE PERFORMANCE On-Board Diagnostic (MZI-3.5) - CX-9

**CRUISE CONTROL SWITCH**

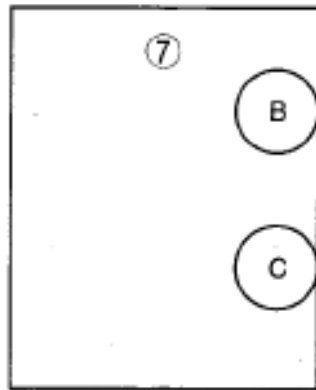

**PCM**

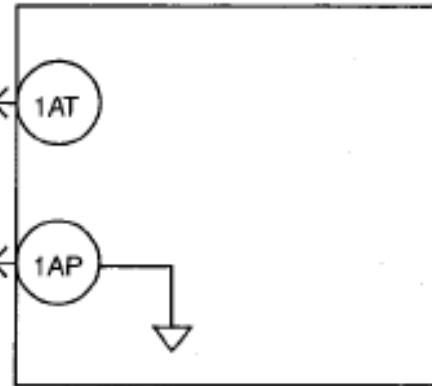

**PCM  
WIRING HARNESS-SIDE CONNECTOR**

**CRUISE CONTROL SWITCH  
WIRING HARNESS-SIDE CONNECTOR**

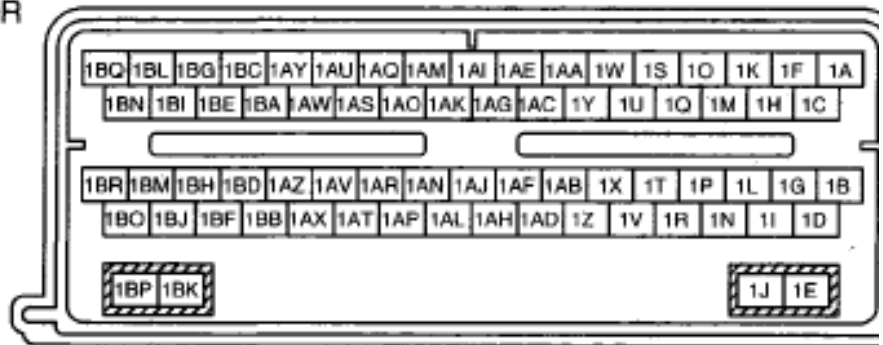

### DIAGNOSTIC PROCEDURE

#### DTC P0581 (MZI-3.5) DIAGNOSTIC PROCEDURE

STEP	INSPECTION		ACTION
1	<b>VERIFY FREEZE FRAME DATA HAS BEEN RECORDED</b>  • Has FREEZE FRAME DATA been recorded?	Yes	Go to the next step.
		No	Record FREEZE FRAME DATA on the repair order, then go to the next step.
2	<b>VERIFY RELATED REPAIR INFORMATION AVAILABILITY</b>  • Verify related Service Bulletins and/or on-line repair information	Yes	Perform repair or diagnosis according Service Bulletins.  • If the vehicle is not repaired, go to, to the available the next step.

## 2007 Mazda CX-9 Grand Touring

2007 ENGINE PERFORMANCE On-Board Diagnostic (MZI-3.5) - CX-9

	<p>availability.</p> <ul style="list-style-type: none"> <li>• Is any related Service Bulletins available?</li> </ul>	No	Go to the next step.
3	<p><b>INSPECT CRUISE CONTROL SWITCH CONNECTOR FOR POOR CONNECTION</b></p> <ul style="list-style-type: none"> <li>• Turn the ignition switch to off.</li> <li>• Disconnect the cruise control switch connector.</li> <li>• Inspect for poor connection (such as damaged/pulled-out pins, corrosion).</li> <li>• Are there any malfunction?</li> </ul>	Yes	Repair or replace suspected part, then go to Step 8.
		No	Go to the next step.
4	<p><b>INSPECT CRUISE CONTROL SWITCH CIRCUIT FOR SHORT TO POWER SUPPLY</b></p> <ul style="list-style-type: none"> <li>• Turn the ignition switch to the ON position (Engine off).</li> <li>• Measure the voltage between the following terminals: <ul style="list-style-type: none"> <li>○ Cruise control switch terminal B and body ground</li> <li>○ Cruise control switch terminal C and body ground</li> </ul> </li> <li>• Are there voltage B+?</li> </ul>	Yes	Repair or replace suspected part, then go to Step 8.
		No	Go to the next step.
5	<p><b>INSPECT PCM CONNECTOR FOR POOR CONNECTION</b></p> <ul style="list-style-type: none"> <li>• Turn the ignition switch off.</li> <li>• Disconnect the PCM connector.</li> <li>• Inspect for poor connection (such as damaged/pulled-out pins, corrosion).</li> <li>• Are there any malfunction?</li> </ul>	Yes	Repair or replace suspected part, then go to Step 8.
		No	Go to the next step.
6	<p><b>INSPECT CRUISE CONTROL SWITCH CIRCUIT FOR OPEN</b></p> <ul style="list-style-type: none"> <li>• Disconnect the PCM connector.</li> <li>• Inspect for continuity between the following terminals: <ul style="list-style-type: none"> <li>○ Cruise control switch</li> </ul> </li> </ul>	Yes	Go to the next step.
		No	Repair or replace suspected part, then go to Step 8.

## 2007 Mazda CX-9 Grand Touring

2007 ENGINE PERFORMANCE On-Board Diagnostic (MZI-3.5) - CX-9

	<p>terminal B and PCM terminal 1AT</p> <ul style="list-style-type: none"> <li>○ Cruise control switch terminal C and PCM terminal 1AP</li> </ul> <ul style="list-style-type: none"> <li>● Is there continuity?</li> </ul>		
7	<p><b>INSPECT CRUISE CONTROL SWITCH</b></p> <ul style="list-style-type: none"> <li>● Inspect the cruise control switch.</li> </ul> <p>(see <b><u>CRUISE CONTROL SWITCH INSPECTION [MZI-3.5]</u></b> .)</p> <ul style="list-style-type: none"> <li>● Is there malfunction?</li> </ul>	Yes	Replace the cruise control switch, then go to the next step.
		No	Go to the next step.
8	<p><b>VERIFY TROUBLESHOOTING OF DTC P0581 HAS BEEN COMPLETED</b></p> <ul style="list-style-type: none"> <li>● Verify that all disconnected connectors are reconnected.</li> <li>● Turn the ignition switch to the ON position (Engine off).</li> <li>● Clear the DTC from the PCM memory using the M-MDS.</li> <li>● Perform the "KOEO and KOER self-test".</li> </ul> <p>(See <b><u>KOEO/KOER SELF TEST [MZI-3.5]</u></b>.)</p> <ul style="list-style-type: none"> <li>● Retrieve DTCs using the M-MDS.</li> <li>● Is the PENDING CODE for this DTC present?</li> </ul>	Yes	Replace the PCM, then go to the next step. (see <b><u>PCM REMOVAL/INSTALLATION [MZI-3.5]</u></b> .)
		No	Go to the next step.
9	<p><b>VERIFY AFTER REPAIR PROCEDURE</b></p> <ul style="list-style-type: none"> <li>● Perform the "AFTER REPAIR PROCEDURE".</li> </ul> <p>(See <b><u>AFTER REPAIR PROCEDURE [MZI-3.5]</u></b>.)</p> <ul style="list-style-type: none"> <li>● Are any DTCs present?</li> </ul>	Yes	Go to the applicable DTC inspection. (See <b><u>DTC TABLE [MZI-3.5]</u></b> .)
		No	Troubleshooting completed.

## 2007 Mazda CX-9 Grand Touring

2007 ENGINE PERFORMANCE On-Board Diagnostic (MZI-3.5) - CX-9

### DTC P0600 [MZI-3.5]

#### DTC P0600 (MZI-3.5) DETECTION CONDITION AND POSSIBLE CAUSES

<b>DTC P0600</b>	<b>Serial communication link</b>
<b>DETECTION CONDITION</b>	<ul style="list-style-type: none"> <li>Indicates an error occurred in the PCM. This DTC may be set alone or in combination with P2105.</li> </ul>
<b>POSSIBLE CAUSE</b>	<ul style="list-style-type: none"> <li>PCM malfunction</li> </ul>

#### DIAGNOSTIC PROCEDURE

#### DTC P0600 (MZI-3.5) DIAGNOSTIC PROCEDURE

STEP	INSPECTION		ACTION
1	<b>VERIFY FREEZE FRAME DATA HAS BEEN RECORDED</b> <ul style="list-style-type: none"> <li>Has FREEZE FRAME DATA been recorded?</li> </ul>	Yes	Go to the next step.
		No	Record FREEZE FRAME DATA on the repair order, then go to the next step.
2	<b>VERIFY RELATED REPAIR INFORMATION AVAILABILITY</b> <ul style="list-style-type: none"> <li>Verify related Service Bulletins and/or on-line repair information availability.</li> <li>Is any related Service Bulletins available?</li> </ul>	Yes	Perform repair or diagnosis according to the available Service Bulletins. <ul style="list-style-type: none"> <li>If the vehicle is not repaired, go to the next step.</li> </ul>
		No	Go to the next step.
3	<b>INSPECT FOR CORRECT PCM OPERATION</b> <ul style="list-style-type: none"> <li>Disconnect all the PCM connectors.</li> <li>Visually inspect for:               <ul style="list-style-type: none"> <li>Pushed out pins</li> <li>Corrosion</li> </ul> </li> <li>Connect all the PCM connectors and verify that they seat correctly.</li> <li>Retrieve DTCs using the M-MDS.</li> <li>Is the PENDING CODE for this DTC present?</li> </ul>	Yes	Go to the next step.
		No	The system is correctly. Go to the next step.
4	<b>VERIFY TROUBLESHOOTING OF DTC P0600 HAS BEEN COMPLETED</b> <ul style="list-style-type: none"> <li>Verify that all disconnected</li> </ul>	Yes	Replace the PCM, then go to the next step. (see <b><u>PCM REMOVAL/INSTALLATION [MZI-3.5]</u></b> .)

## 2007 Mazda CX-9 Grand Touring

2007 ENGINE PERFORMANCE On-Board Diagnostic (MZI-3.5) - CX-9

	<p>connectors are reconnected.</p> <ul style="list-style-type: none"> <li>• Turn the ignition switch to the ON position (Engine off).</li> <li>• Clear the DTC from the PCM memory using the M-MDS.</li> <li>• Perform the KOEO and KOER self-test.</li> <li>• Retrieve DTCs using the M-MDS.</li> <li>• Is the PENDING CODE for this DTC present?</li> </ul>	No	Go to the next step.
5	<p><b>VERIFY AFTER REPAIR PROCEDURE</b></p> <ul style="list-style-type: none"> <li>• Perform "AFTER REPAIR PROCEDURE".</li> </ul> <p>(See <b><u>AFTER REPAIR PROCEDURE [MZI-3.5].</u></b>)</p> <ul style="list-style-type: none"> <li>• Are any DTCs present?</li> </ul>	Yes	Go to the applicable DTC inspection. (See <b><u>DTC TABLE [MZI-3.5].</u></b> )
		No	Troubleshooting completed.

### DTC P0602 [MZI-3.5]

#### DTC P0602 (MZI-3.5) DETECTION CONDITION AND POSSIBLE CAUSES

<b>DTC P0602</b>	<b>PCM programming error</b>
<b>DETECTION CONDITION</b>	<ul style="list-style-type: none"> <li>• This DTC indicates a programming error within the vehicle ID block.</li> </ul>
<b>POSSIBLE CAUSE</b>	<ul style="list-style-type: none"> <li>• Vehicle ID data corrupted by the M-MDS during vehicle ID reprogramming</li> </ul>

#### DIAGNOSTIC PROCEDURE

#### DTC P0602 (MZI-3.5) DIAGNOSTIC PROCEDURE

STEP	INSPECTION		ACTION
1	<p><b>VERIFY FREEZE FRAME DATA HAS BEEN RECORDED</b></p> <ul style="list-style-type: none"> <li>• Has FREEZE FRAME DATA been recorded?</li> </ul>	Yes	Go to the next step.
		No	Record FREEZE FRAME DATA on the repair order, then go to the next step.
2	<p><b>VERIFY RELATED REPAIR INFORMATION AVAILABILITY</b></p> <ul style="list-style-type: none"> <li>• Verify related Service Bulletins and/or on-line repair information</li> </ul>	Yes	<p>Perform repair or diagnosis according to the available Service Bulletins.</p> <ul style="list-style-type: none"> <li>• If the vehicle is not repaired, go to the next step.</li> </ul>

## 2007 Mazda CX-9 Grand Touring

2007 ENGINE PERFORMANCE On-Board Diagnostic (MZI-3.5) - CX-9

	<p>availability.</p> <ul style="list-style-type: none"> <li>• Is any related Service Bulletins available?</li> </ul>	No	Reprogram the vehicle ID using the M-MDS, then go to the next step.
3	<p><b>VERIFY TROUBLESHOOTING OF DTC P0602 HAS BEEN COMPLETED</b></p> <ul style="list-style-type: none"> <li>• Verify that all disconnected connectors are reconnected.</li> <li>• Turn the ignition switch to the ON position (Engine off).</li> <li>• Clear the DTC from the PCM memory using the M-MDS.</li> <li>• Perform the "KOEO and KOER self-test".</li> </ul> <p>(See <b><u>KOEO/KOER SELF TEST [MZI-3.5].</u></b>)</p> <ul style="list-style-type: none"> <li>• Retrieve DTCs using the M-MDS.</li> <li>• Is the PENDING CODE for this DTC present?</li> </ul>	Yes	Replace the PCM, then go to the next step. (see <b><u>PCM REMOVAL/INSTALLATION [MZI-3.5]</u></b> .)
		No	Go to the next step.
4	<p><b>VERIFY AFTER REPAIR PROCEDURE</b></p> <ul style="list-style-type: none"> <li>• Perform the "After Repair Procedure".</li> </ul> <p>(See <b><u>AFTER REPAIR PROCEDURE [MZI-3.5].</u></b>)</p> <ul style="list-style-type: none"> <li>• Are any DTCs present?</li> </ul>	Yes	Go to the applicable DTC inspection. (See <b><u>DTC TABLE [MZI-3.5].</u></b> )
		No	Troubleshooting completed.

### DTC P0603 [MZI-3.5]

#### DTC P0603 (MZI-3.5) DETECTION CONDITION AND POSSIBLE CAUSES

<b>DTC P0603</b>	<b>PCM keep alive memory (KAM) error</b>
<b>DETECTION CONDITION</b>	<ul style="list-style-type: none"> <li>• Indicates the PCM has experienced an internal memory concern. However, there are external items that can cause this DTC.</li> </ul>
<b>POSSIBLE CAUSE</b>	<ul style="list-style-type: none"> <li>• Reprogramming</li> <li>• Battery terminal corrosion</li> <li>• Open circuit between battery positive terminal and PCM terminal 1BB</li> <li>• Connector or terminal malfunction</li> </ul>



## 2007 Mazda CX-9 Grand Touring

2007 ENGINE PERFORMANCE On-Board Diagnostic (MZI-3.5) - CX-9

- Loose battery connection

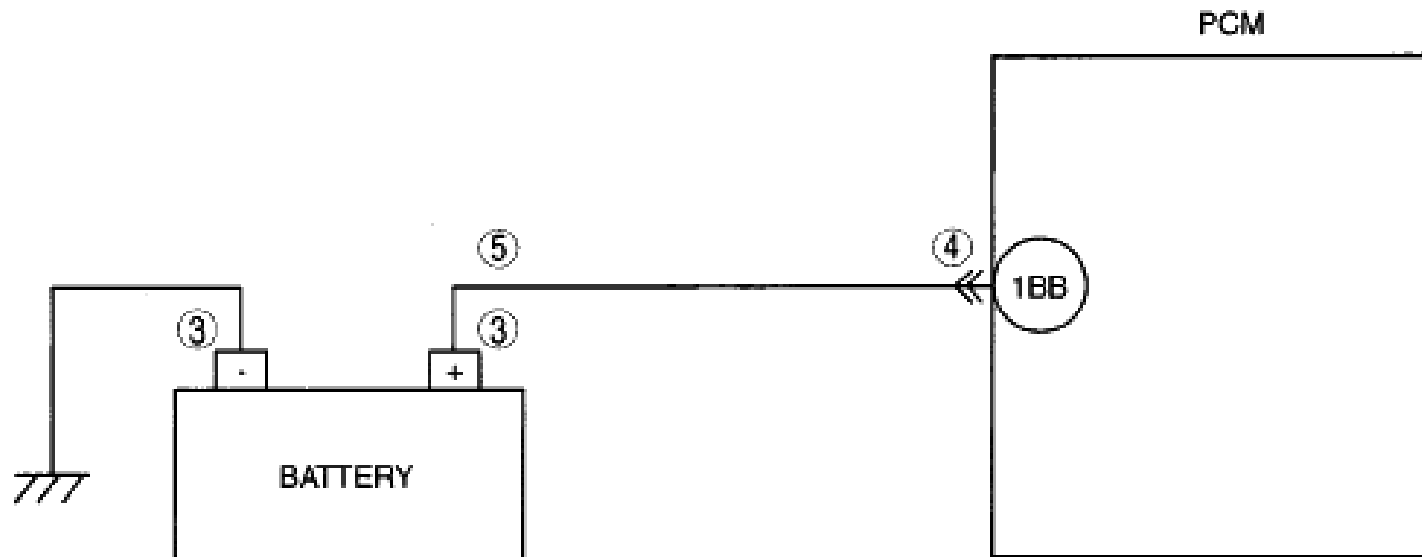

PCM  
WIRING HARNESS-SIDE CONNECTOR

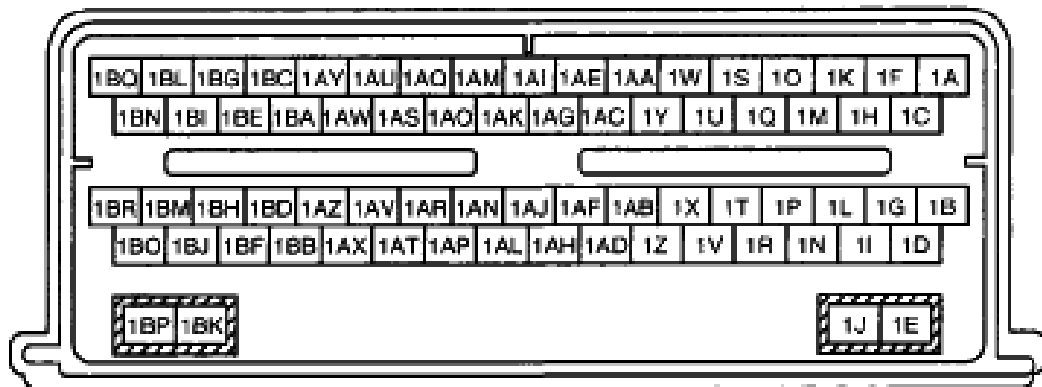

### DIAGNOSTIC PROCEDURE

#### DTC P0603 (MZI-3.5) DIAGNOSTIC PROCEDURE

STEP	INSPECTION		ACTION
1	VERIFY FREEZE FRAME DATA	Yes	Go to the next step.

## 2007 Mazda CX-9 Grand Touring

2007 ENGINE PERFORMANCE On-Board Diagnostic (MZI-3.5) - CX-9

	<p><b>HAS BEEN RECORDED</b></p> <ul style="list-style-type: none"> <li>• Has FREEZE FRAME DATA been recorded?</li> </ul>	No	Record FREEZE FRAME DATA on the repair order, then go to the next step.
2	<p><b>VERIFY RELATED REPAIR INFORMATION AVAILABILITY</b></p> <ul style="list-style-type: none"> <li>• Verify related Service Bulletins and/or on-line repair information availability.</li> <li>• Is any Service Bulletins available?</li> </ul>	Yes	<p>Perform repair or diagnosis according to available Service Bulletins.</p> <ul style="list-style-type: none"> <li>• If vehicle is not repaired, go to the next step.</li> </ul>
		No	Go to the next step.
3	<p><b>INSPECT BATTERY TERMINALS FOR POOR CONNECTION</b></p> <ul style="list-style-type: none"> <li>• Turn the ignition switch off.</li> <li>• Inspect for poor connection and corrosion.</li> <li>• Are there any malfunction?</li> </ul>	Yes	Repair or replace suspected part, then go to Step 7.
		No	Go to the next step.
4	<p><b>INSPECT PCM CONNECTOR FOR POOR CONNECTION</b></p> <ul style="list-style-type: none"> <li>• Turn the ignition switch off.</li> <li>• Disconnect the PCM connector.</li> <li>• Inspect for poor connection (such as damaged/pulled-out pins, corrosion).</li> <li>• Is there any malfunction?</li> </ul>	Yes	Repair or replace suspected part, then go to Step 7.
		No	Go to the next step.
5	<p><b>INSPECT MONITOR CIRCUIT FOR OPEN CIRCUIT</b></p> <ul style="list-style-type: none"> <li>• Turn the ignition switch off.</li> <li>• Disconnect the battery cables.</li> <li>• Disconnect the PCM connector.</li> <li>• Inspect the continuity between battery positive terminal (wiring harness-side) and PCM terminal IBB (wiring harness-side).</li> <li>• Is there continuity?</li> </ul>	Yes	Go to the next step.
		No	Repair or replace suspected part, then go to Step 7.
6	<p><b>INSPECT FOR CORRECT PCM OPERATION</b></p> <ul style="list-style-type: none"> <li>• Disconnect all the PCM connectors.</li> </ul>	Yes	Go to the next step.

## 2007 Mazda CX-9 Grand Touring

2007 ENGINE PERFORMANCE On-Board Diagnostic (MZI-3.5) - CX-9

	<ul style="list-style-type: none"> <li>• Visually inspect for:             <ul style="list-style-type: none"> <li>○ Pushed out pins</li> <li>○ Corrosion</li> </ul> </li> <li>• Connect all the PCM connectors and verify that they seat correctly.</li> <li>• Retrieve DTCs using the M-MDS.</li> <li>• Is the PENDING CODE for this DTC present?</li> </ul>	No	The system is correctly. Go to the next step.
7	<p><b>VERIFY TROUBLESHOOTING OF DTC P0603 HAS BEEN COMPLETED</b></p> <ul style="list-style-type: none"> <li>• Verify that all disconnected connectors are reconnected.</li> <li>• Turn the ignition switch to the ON position (Engine off).</li> <li>• Clear the DTC from the PCM memory using the M-MDS.</li> <li>• Perform the "KOEO and KOER self-test".</li> </ul> <p>(See <b><u>KOEO/KOER SELF TEST [MZI-3.5].</u></b>)</p> <ul style="list-style-type: none"> <li>• Retrieve DTCs using the M-MDS.</li> <li>• Is the PENDING CODE for this DTC present?</li> </ul>	Yes	Replace the PCM, then go to the next step. (see <b><u>PCM REMOVAL/INSTALLATION [MZI-3.5].</u></b> )
		No	Go to the next step.
8	<p><b>VERIFY AFTER REPAIR PROCEDURE</b></p> <ul style="list-style-type: none"> <li>• Perform the "AFTER REPAIR PRECAUTION".</li> </ul> <p>(See <b><u>AFTER REPAIR PROCEDURE [MZI-3.5].</u></b>)</p> <ul style="list-style-type: none"> <li>• Are any DTCs present?</li> </ul>	Yes	Go to the applicable DTC inspection. (See <b><u>DTC TABLE [MZI-3.5].</u></b> )
		No	Troubleshooting completed.

### DTC P0604 [MZI-3.5]

#### DTC P0604 (MZI-3.5) DETECTION CONDITION AND POSSIBLE CAUSES

<b>DTC P0604</b>	<b>Internal control module random access memory (RAM) error</b>
<b>DETECTION</b>	<ul style="list-style-type: none"> <li>• Indicates the PCM RAM has been corrupted.</li> </ul>

## 2007 Mazda CX-9 Grand Touring

2007 ENGINE PERFORMANCE On-Board Diagnostic (MZI-3.5) - CX-9

<b>CONDITION</b>	
<b>POSSIBLE CAUSE</b>	<ul style="list-style-type: none"> <li>• Module reprogramming</li> <li>• Aftermarket performance products.</li> <li>• PCM malfunction</li> </ul>

### DIAGNOSTIC PROCEDURE

#### DTC P0604 (MZI-3.5) DIAGNOSTIC PROCEDURE

STEP	INSPECTION		ACTION
1	<b>VERIFY FREEZE FRAME DATA HAS BEEN RECORDED.</b> <ul style="list-style-type: none"> <li>• Has FREEZE FRAME DATA been recorded?</li> </ul>	Yes	Go to the next step.
		No	Record FREEZE FRAME DATA on the repair order, then go to the next step.
2	<b>VERIFY RELATED REPAIR INFORMATION AVAILABILITY</b> <ul style="list-style-type: none"> <li>• Verify related Service Bulletins and/or on-line repair information availability.</li> <li>• Is any related Service Bulletins available?</li> </ul>	Yes	Perform repair or diagnosis according to the available Service Bulletins. <ul style="list-style-type: none"> <li>• If the vehicle is not repaired, go to the next step.</li> </ul>
		No	Perform PCM reprogramming using the M-MDS, then go to next step.
3	<b>VERIFY TROUBLESHOOTING OF P0604 HAS BEEN COMPLETED</b> <ul style="list-style-type: none"> <li>• Verify that all disconnected connectors are reconnected.</li> <li>• Turn the ignition switch to the ON position (Engine off).</li> <li>• Clear the DTC from the PCM memory using the M-MDS.</li> <li>• Perform the "KOEO and KOER self-test".</li> </ul> <p style="margin-left: 20px;">(See <b><u>KOEO/KOER SELF TEST [MZI-3.5].</u></b>)</p> <ul style="list-style-type: none"> <li>• Retrieve DTCs using the M-MDS.</li> <li>• Is the PENDING CODE for this DTC present?</li> </ul>	Yes	Replace the PCM, go to the next step. (see <b><u>PCM REMOVAL/INSTALLATION [MZI-3.5]</u></b> .)
		No	Go to the next step.
4	<b>VERIFY AFTER REPAIR PROCEDURE</b> <ul style="list-style-type: none"> <li>• Perform the "After Repair</li> </ul>	Yes	Go to the applicable DTC inspection. (See <b><u>DTC TABLE [MZI-3.5].</u></b> )

## 2007 Mazda CX-9 Grand Touring

2007 ENGINE PERFORMANCE On-Board Diagnostic (MZI-3.5) - CX-9

<p>Procedure".</p> <p>(See <b><u>AFTER REPAIR PROCEDURE [MZI-3.5].</u></b>)</p> <ul style="list-style-type: none"> <li>• Are any DTCs present?</li> </ul>	<p>No</p>	<p>Troubleshooting completed.</p>
---	-----------	-----------------------------------

### DTC P0605 [MZI-3.5]

#### DTC P0605 (MZI-3.5) DETECTION CONDITION AND POSSIBLE CAUSES

<b>DTC P0605</b>	<b>PCM read only memory (ROM) error</b>
<b>DETECTION CONDITION</b>	<ul style="list-style-type: none"> <li>• The PCM ROM has been corrupted.</li> </ul>
<b>POSSIBLE CAUSE</b>	<ul style="list-style-type: none"> <li>• An attempt was made to change the calibration</li> <li>• Module programming error</li> <li>• PCM malfunction</li> </ul>

#### DIAGNOSTIC PROCEDURE

#### DTC P0605 (MZI-3.5) DIAGNOSTIC PROCEDURE

STEP	INSPECTION		ACTION
1	<b>VERIFY FREEZE FRAME DATA HAS BEEN RECORDED.</b> <ul style="list-style-type: none"> <li>• Has FREEZE FRAME DATA been recorded?</li> </ul>	Yes	Go to next step.
		No	Record FREEZE FRAME DATA on the repair order, then go to next step.
2	<b>VERIFY RELATED REPAIR INFORMATION AVAILABILITY</b> <ul style="list-style-type: none"> <li>• Verify related Service Bulletins and/or on-line repair information availability.</li> <li>• Is any related Service Bulletins available?</li> </ul>	Yes	Perform repair or diagnosis according to available Service Bulletins. <ul style="list-style-type: none"> <li>• If vehicle is not repaired, go to next step.</li> </ul>
		No	Perform PCM reprogramming using the M-MDS, then go to next step.
3	<b>VERIFY TROUBLESHOOTING OF DTC P0605 HAS BEEN COMPLETED</b> <ul style="list-style-type: none"> <li>• Verify that all disconnected connectors are reconnected.</li> <li>• Turn the ignition switch to the ON position (Engine off).</li> <li>• Clear the DTC from the PCM</li> </ul>	Yes	Replace the PCM, then go to next step. (see <b><u>PCM REMOVAL/INSTALLATION [MZI-3.5]</u></b> .)

## 2007 Mazda CX-9 Grand Touring

2007 ENGINE PERFORMANCE On-Board Diagnostic (MZI-3.5) - CX-9

	<p>memory using the M-MDS.</p> <ul style="list-style-type: none"> <li>Perform the "KOEO and KOER self-test".</li> </ul> <p>(See <b><u>KOEO/KOER SELF TEST [MZI-3.5]</u></b>.)</p> <ul style="list-style-type: none"> <li>Retrieve DTCs using the M-MDS.</li> <li>Is the PENDING CODE for this DTC present?</li> </ul>	No	Go to next step.
4	<p><b>VERIFY AFTER REPAIR PROCEDURE</b></p> <ul style="list-style-type: none"> <li>Perform the "AFTER REPAIR PRECAUTION".</li> </ul> <p>(See <b><u>AFTER REPAIR PROCEDURE [MZI-3.5]</u></b>.)</p> <ul style="list-style-type: none"> <li>Are any DTCs present?</li> </ul>	Yes	Go to the applicable DTC inspection. (See <b><u>DTC TABLE [MZI-3.5]</u></b> .)
		No	Troubleshooting completed.

### DTC P0606 [MZI-3.5]

#### DTC P0606 (MZI-3.5) DETECTION CONDITION AND POSSIBLE CAUSES

<b>DTC P0606</b>	<b>ECM/PCM processor</b>
<b>DETECTION CONDITION</b>	<ul style="list-style-type: none"> <li>This DTC indicates a register hardback (PCM internal communications) error.</li> </ul>
<b>POSSIBLE CAUSE</b>	<ul style="list-style-type: none"> <li>PCM malfunction</li> </ul>

#### DIAGNOSTIC PROCEDURE

#### DTC P0606 (MZI-3.5) DIAGNOSTIC PROCEDURE

STEP	INSPECTION		ACTION
1	<p><b>VERIFY FREEZE FRAME DATA HAS BEEN RECORDED</b></p> <ul style="list-style-type: none"> <li>Has FREEZE FRAME DATA been recorded?</li> </ul>	Yes	Go to the next step.
		No	Record FREEZE FRAME DATA on the repair order, then go to the next step.
2	<p><b>VERIFY RELATED REPAIR INFORMATION AVAILABILITY</b></p> <ul style="list-style-type: none"> <li>Verify related Service Bulletins and/or on-line repair information availability.</li> </ul>	Yes	Perform repair or diagnosis according to the available Service Bulletins.
			<ul style="list-style-type: none"> <li>If the vehicle is not repaired, go to the next step.</li> </ul>

## 2007 Mazda CX-9 Grand Touring

2007 ENGINE PERFORMANCE On-Board Diagnostic (MZI-3.5) - CX-9

	<ul style="list-style-type: none"> <li>Is any related Service Bulletins available?</li> </ul>	No	Perform PCM reprogramming using the M-MDS, then go to next step.
3	<p><b>VERIFY TROUBLESHOOTING OF P0606 HAS BEEN COMPLETED</b></p> <ul style="list-style-type: none"> <li>Verify that all disconnected connectors are reconnected.</li> <li>Turn the ignition switch to the ON position (Engine off).</li> <li>Clear the DTC from the PCM memory using the M-MDS.</li> <li>Perform the "KOEO and KOER self-test".</li> </ul> <p>(See <b>KOEO/KOER SELF TEST [MZI-3.5]</b>.)</p> <ul style="list-style-type: none"> <li>Retrieve DTCs using the M-MDS.</li> <li>Is the PENDING CODE for this DTC present?</li> </ul>	Yes	Replace the PCM, go to the next step. (see <b>PCM REMOVAL/INSTALLATION [MZI-3.5]</b> .)
		No	Go to the next step.
4	<p><b>VERIFY AFTER REPAIR PROCEDURE</b></p> <ul style="list-style-type: none"> <li>Perform the "After Repair Procedure".</li> </ul> <p>(See <b>AFTER REPAIR PROCEDURE [MZI-3.5]</b>.)</p> <ul style="list-style-type: none"> <li>Are any DTCs present?</li> </ul>	Yes	Go to the applicable DTC inspection. (See <b>DTC TABLE [MZI-3.5]</b> .)
		No	Troubleshooting completed.

### DTC P0607 [MZI-3.5]

#### DTC P0607 (MZI-3.5) DETECTION CONDITION AND POSSIBLE CAUSES

<b>DTC P0607</b>	<b>Control module performance</b>
<b>DETECTION CONDITION</b>	<ul style="list-style-type: none"> <li>Indicates that the PCM internal CPU has encountered an error. The PGM monitors itself and carries out internal checks of its own CPU. If any of these checks returns an incorrect value, the DTC is set.</li> </ul>
<b>POSSIBLE CAUSE</b>	<ul style="list-style-type: none"> <li>PCM malfunction</li> </ul>

#### DIAGNOSTIC PROCEDURE

#### DTC P0607 (MZI-3.5) DIAGNOSTIC PROCEDURE

--	--	--

## 2007 Mazda CX-9 Grand Touring

2007 ENGINE PERFORMANCE On-Board Diagnostic (MZI-3.5) - CX-9

STEP	INSPECTION	ACTION	
1	<b>VERIFY FREEZE FRAME DATA HAS BEEN RECORDED</b> <ul style="list-style-type: none"> <li>• Has FREEZE FRAME DATA been recorded?</li> </ul>	Yes	Go to the next step.
		No	Record FREEZE FRAME DATA on the repair order, then go to the next step.
2	<b>VERIFY RELATED REPAIR INFORMATION AVAILABILITY</b> <ul style="list-style-type: none"> <li>• Verify related Service Bulletins and/or on-line repair information availability.</li> <li>• Is any related Service Bulletins available?</li> </ul>	Yes	Perform repair or diagnosis according to the available Service Bulletins. <ul style="list-style-type: none"> <li>• If the vehicle is not repaired, go to the next step.</li> </ul>
		No	Perform PCM reprogramming using the M-MDS, then go to next step.
3	<b>VERIFY TROUBLESHOOTING OF DTC P0607 HAS BEEN COMPLETED</b> <ul style="list-style-type: none"> <li>• Verify that all disconnected connectors are reconnected.</li> <li>• Turn the ignition switch to the ON position (Engine off).</li> <li>• Clear the DTC from the PCM memory using the M-MDS.</li> <li>• Perform "KOEO and KOER self-test".</li> </ul> <p style="margin-left: 20px;">(See <b>KOEO/KOER SELF TEST [MZI-3.5].</b>)</p> <ul style="list-style-type: none"> <li>• Retrieve DTCs using the M-MDS.</li> <li>• Is the PENDING CODE for this DTC present?</li> </ul>	Yes	Replace the PCM, then go to the next step. (see <b>PCM REMOVAL/INSTALLATION [MZI-3.5]</b> .)
		No	Go to the next step.
4	<b>VERIFY AFTER REPAIR PROCEDURE</b> <ul style="list-style-type: none"> <li>• Perform the "AFTER REPAIR PROCEDURE".</li> </ul> <p style="margin-left: 20px;">(See <b>AFTER REPAIR PROCEDURE [MZI-3.5].</b>)</p> <ul style="list-style-type: none"> <li>• Are any DTCs present?</li> </ul>	Yes	Go to the applicable DTC inspection. (see <b>DTC TABLE [MZI-3.5].</b> )
		No	Troubleshooting completed.

**DTC P060A, P060C, P061D [MZI-3.5]**



## 2007 Mazda CX-9 Grand Touring

2007 ENGINE PERFORMANCE On-Board Diagnostic (MZI-3.5) - CX-9

### DTC P060A, P060C, P061D (MZI-3.5) DETECTION CONDITION AND POSSIBLE CAUSES

<b>DTC P060A</b>	<b>P060A: Internal control module monitoring processor performance</b>
<b>DTC P060C</b>	<b>P060C: Internal control module main processor performance</b>
<b>DTCP061D</b>	<b>P061 D: Internal control module engine air mass performance</b>
<b>DETECTION CONDITION</b>	<ul style="list-style-type: none"> <li>Indicates an error occurred in the PCM.</li> </ul>
<b>POSSIBLE CAUSE</b>	<ul style="list-style-type: none"> <li>Software incompatibility issue</li> <li>PCM malfunction</li> </ul>

### DIAGNOSTIC PROCEDURE

#### DTC P060A, P060C, P061D (MZI-3.5) DIAGNOSTIC PROCEDURE

STEP	INSPECTION		ACTION
1	<b>VERIFY FREEZE FRAME DATA HAS BEEN RECORDED</b> <ul style="list-style-type: none"> <li>Has FREEZE FRAME DATA been recorded?</li> </ul>	Yes	Go to the next step.
		No	Record FREEZE FRAME DATA on the repair order, then go to the next step.
2	<b>VERIFY RELATED REPAIR INFORMATION AVAILABILITY</b> <ul style="list-style-type: none"> <li>Verify related Service Bulletins and/or on-line repair information availability.</li> <li>Is any related Service Bulletins available?</li> </ul>	Yes	Perform repair or diagnosis according to the available Service Bulletins. <ul style="list-style-type: none"> <li>If the vehicle is not repaired, go to the next step.</li> </ul>
		No	Go to the next step.
3	<b>INSPECT PCM FOR LATEST CALIBRATION</b> <ul style="list-style-type: none"> <li>Program the PCM to the latest calibration.</li> <li>Turn the ignition switch off.</li> <li>Perform the KOEO self-test.</li> <li>Turn the ignition switch off.</li> <li>Perform the KOER self-test.</li> <li>Use the customer information to recreate the concern.</li> <li>Perform the self-test.</li> <li>Are DTCs P060A, P060C or P060D present?</li> </ul>	Yes	Go to the next step.
		No	Go to Step 5.
4	<b>INSPECT FOR CORRECT PCM OPERATION</b>	Yes	Replace the PCM, then go to the next step. (see <b>PCM REMOVAL/INSTALLATION [MZI-</b>

## 2007 Mazda CX-9 Grand Touring

2007 ENGINE PERFORMANCE On-Board Diagnostic (MZI-3.5) - CX-9

	<ul style="list-style-type: none"> <li>• Disconnect all the PCM connectors.</li> <li>• Visually inspect for: <ul style="list-style-type: none"> <li>○ Pushed out pins</li> <li>○ Corrosion</li> </ul> </li> <li>• Connect all the PCM connectors and verify that they seat correctly.</li> <li>• Retrieve DTCs using the M-MDS.</li> <li>• Is the PENDING CODE for this DTC present?</li> </ul>		<u>3.5</u> .)
		No	Go to the next step.
5	<p><b>VERIFY TROUBLESHOOTING OF MISFIRE DTC P060A, P060C AND P061D HAS BEEN COMPLETED</b></p> <ul style="list-style-type: none"> <li>• Verify that all disconnected connectors reconnected.</li> <li>• Turn the ignition switch to the ON position (Engine off).</li> <li>• Clear the DTC from the PCM memory using the M-MDS.</li> <li>• Perform the "KOEO and KOER self-test".</li> </ul> <p>(See <b><u>KOEO/KOER SELF TEST [MZI-3.5].</u></b>)</p> <ul style="list-style-type: none"> <li>• Retrieve DTCs using the M-MDS.</li> <li>• Is the PENDING CODE for this DTC present?</li> </ul>	Yes	Replace the PCM, then go to the next step. (see <b><u>PCM REMOVAL/INSTALLATION [MZI-3.5] .</u></b> )
		No	Go to the next step.
6	<p><b>VERIFY AFTER REPAIR PROCEDURE</b></p> <ul style="list-style-type: none"> <li>• Perform the "AFTER REPAIR PROCEDURE".</li> </ul> <p>(See <b><u>AFTER REPAIR PROCEDURE [MZI-3.5].</u></b>)</p> <ul style="list-style-type: none"> <li>• Are any DTCs present?</li> </ul>	Yes	Go to the applicable DTC inspection. (See <b><u>DTC TABLE [MZI-3.5].</u></b> )
		No	Troubleshooting completed.

### DTC P060B [MZI-3.5]

#### DTC P060B (MZI-3.5) DETECTION CONDITION AND POSSIBLE CAUSES

## 2007 Mazda CX-9 Grand Touring

2007 ENGINE PERFORMANCE On-Board Diagnostic (MZI-3.5) - CX-9

<b>DTC P060B</b>	<b>Internal control module A/D processing performance</b>
<b>DETECTION CONDITION</b>	<ul style="list-style-type: none"> <li>Indicates that an error occurred in the PCM.</li> </ul>
<b>POSSIBLE CAUSE</b>	<ul style="list-style-type: none"> <li>PCM malfunction</li> </ul>

### DIAGNOSTIC PROCEDURE

#### DTC P060B (MZI-3.5) DIAGNOSTIC PROCEDURE

STEP	INSPECTION		ACTION
1	<b>VERIFY FREEZE FRAME DATA HAS BEEN RECORDED</b> <ul style="list-style-type: none"> <li>Has FREEZE FRAME DATA been recorded?</li> </ul>	Yes	Go to the next step.
		No	Record FREEZE FRAME DATA on the repair order, then go to the next step.
2	<b>VERIFY RELATED REPAIR INFORMATION AVAILABILITY</b> <ul style="list-style-type: none"> <li>Verify related Service Bulletins and/or on-line repair information availability.</li> <li>Is any related Service Bulletins available?</li> </ul>	Yes	Perform repair or diagnosis according to the available Service Bulletins. <ul style="list-style-type: none"> <li>If the vehicle is not repaired, go to the next step.</li> </ul>
		No	Go to the next step.
3	<b>VERIFY RELATED PENDING CODE OR STORED DTCs</b> <ul style="list-style-type: none"> <li>Turn the ignition switch off then to the ON position (Engine off).</li> <li>Verify related pending code or stored DTCs.</li> <li>Are other DTCs present?</li> </ul>	Yes	Go to the appropriate DTC troubleshooting. (See <b><u>DTC TABLE [MZI-3.5]</u></b> .)
		No	Go to the next step.
4	<b>INSPECT FOR REFERENCE VOLTAGE CONCERNS</b> <ul style="list-style-type: none"> <li>Inspect the PCM wiring harness for damage.</li> <li>Verify the correct operation of the sensors using ETCRER VREF and related circuits.</li> <li>Is a concern present?</li> </ul>	Yes	Go to the next step.
		No	Go to Step 6.
5	<b>INSPECT FOR CORRECT PCM OPERATION</b> <ul style="list-style-type: none"> <li>Disconnect all the PCM connectors.</li> </ul>	Yes	Replace the PCM, then go to the next step. (see <b><u>PCM REMOVAL/INSTALLATION [MZI-3.5]</u></b> .)

## 2007 Mazda CX-9 Grand Touring

2007 ENGINE PERFORMANCE On-Board Diagnostic (MZI-3.5) - CX-9

	<ul style="list-style-type: none"> <li>• Visually inspect for:             <ul style="list-style-type: none"> <li>○ Pushed out pins</li> <li>○ Corrosion</li> </ul> </li> <li>• Connect all the PCM connectors and verify that they seat correctly.</li> <li>• Retrieve DTCs using the M-MDS.</li> <li>• Is the PENDING CODE for this DTC present?</li> </ul>	No	Go to the next step.
6	<p><b>VERIFY TROUBLESHOOTING OF DTC P060B HAS BEEN COMPLETED</b></p> <ul style="list-style-type: none"> <li>• Verify that all disconnected connectors reconnected.</li> <li>• Turn the ignition switch to the ON position (Engine off).</li> <li>• Clear the DTC from the PCM memory using the M-MDS.</li> <li>• Perform the "KOEO and KOER self-test".</li> </ul> <p>(See <b><u>KOEO/KOER SELF TEST [MZI-3.5].</u></b>)</p> <ul style="list-style-type: none"> <li>• Retrieve DTCs using the M-MDS.</li> <li>• Is the PENDING CODE for this DTC present?</li> </ul>	Yes	Replace the PCM, then go to the next step. (see <b><u>PCM REMOVAL/INSTALLATION [MZI-3.5].</u></b> )
		No	Go to the next step.
7	<p><b>VERIFY AFTER REPAIR PROCEDURE</b></p> <ul style="list-style-type: none"> <li>• Perform the "AFTER REPAIR PROCEDURE".</li> </ul> <p>(See <b><u>AFTER REPAIR PROCEDURE [MZI-3.5].</u></b>)</p> <ul style="list-style-type: none"> <li>• Are any DTC present?</li> </ul>	Yes	Go to the applicable DTC inspection. (See <b><u>DTC TABLE [MZI-3.5].</u></b> )
		No	Troubleshooting completed.

### DTC P0610 [MZI-3.5]

#### DTC P0610 (MZI-3.5) DETECTION CONDITION AND POSSIBLE CAUSES

<b>DTC P0610</b>	<b>Control module vehicle options error</b>
<b>DETECTION</b>	<ul style="list-style-type: none"> <li>• Indicates a PCM vehicle options error.</li> </ul>

## 2007 Mazda CX-9 Grand Touring

2007 ENGINE PERFORMANCE On-Board Diagnostic (MZI-3.5) - CX-9

<b>CONDITION</b>	
<b>POSSIBLE CAUSE</b>	<ul style="list-style-type: none"> <li>• Module reprogramming</li> <li>• Aftermarket performance products.</li> <li>• PCM malfunction.</li> </ul>

### DIAGNOSTIC PROCEDURE

#### DTC P0610 (MZI-3.5) DIAGNOSTIC PROCEDURE

STEP	INSPECTION		ACTION
1	<b>VERIFY FREEZE FRAME DATA HAS BEEN RECORDED</b> <ul style="list-style-type: none"> <li>• Has FREEZE FRAME DATA been recorded?</li> </ul>	Yes	Go to the next step.
		No	Record FREEZE FRAME DATA on the repair order, then go to the next step.
2	<b>VERIFY RELATED REPAIR INFORMATION AVAILABILITY</b> <ul style="list-style-type: none"> <li>• Verify related Service Bulletins and/or on-line repair information availability.</li> <li>• Is any related Service Bulletins available?</li> </ul>	Yes	Perform repair or diagnosis according to the available Service Bulletins. <ul style="list-style-type: none"> <li>• If the vehicle is not repaired, go to the next step.</li> </ul>
		No	Perform PCM reprogramming using the M-MDS, then go to next step.
3	<b>VERIFY TROUBLESHOOTING OF DTC P0610 HAS BEEN COMPLETED</b> <ul style="list-style-type: none"> <li>• Verify that all disconnected connectors are reconnected.</li> <li>• Turn the ignition switch to the ON position (Engine off).</li> <li>• Clear the DTC from the PCM memory using the M-MDS.</li> <li>• Perform the "KOEO and KOER self-test".</li> </ul> <p style="margin-left: 20px;">(See <b><u>KOEO/KOER SELF TEST [MZI-3.5].</u></b>)</p> <ul style="list-style-type: none"> <li>• Retrieve DTCs using the M-MDS.</li> <li>• Is the PENDING CODE for this DTC present?</li> </ul>	Yes	Replace the PCM, then go to the next step. (see <b><u>PCM REMOVAL/INSTALLATION [MZI-3.5]</u></b> .)
		No	Go to the next step.
4	<b>VERIFY AFTER REPAIR PROCEDURE</b>	Yes	Go to the applicable DTC inspection. (See <b><u>DTC TABLE [MZI-3.5].</u></b> )

## 2007 Mazda CX-9 Grand Touring

2007 ENGINE PERFORMANCE On-Board Diagnostic (MZI-3.5) - CX-9

	<ul style="list-style-type: none"> <li>Perform the "After Repair Procedure".</li> </ul> <p>(See <b><u>AFTER REPAIR PROCEDURE [MZI-3.5]</u></b>.)</p> <ul style="list-style-type: none"> <li>Are any DTCs present?</li> </ul>	No	Troubleshooting completed.
--	--	----	----------------------------

### DTC P061B [MZI-3.5]

#### DTC P061B (MZI-3.5) DETECTION CONDITION AND POSSIBLE CAUSES

<b>DTC P061B</b>	<b>Internal control module torque calculation performance</b>
<b>DETECTION CONDITION</b>	<ul style="list-style-type: none"> <li>Indicates that a calculation error occurred in the PCM.</li> </ul>
<b>POSSIBLE CAUSE</b>	<ul style="list-style-type: none"> <li>Connector or terminal malfunction</li> </ul> <p><b>NOTE:</b></p> <ul style="list-style-type: none"> <li>This DTC is an informational DTC and may be set in combination with a number of other DTCs which are causing the FMEM. Diagnose other DTCs first.</li> </ul>

#### DIAGNOSTIC PROCEDURE

##### DTC P061B (MZI-3.5) DIAGNOSTIC PROCEDURE

STEP	INSPECTION		ACTION
1	<b>VERIFY FREEZE FRAME DATA HAS BEEN RECORDED</b> <ul style="list-style-type: none"> <li>Has FREEZE FRAME DATA been recorded?</li> </ul>	Yes	Go to the next step.
		No	Record FREEZE FRAME DATA on the repair order, then go to the next step.
2	<b>VERIFY RELATED REPAIR INFORMATION AVAILABILITY</b> <ul style="list-style-type: none"> <li>Verify related Service Bulletins and/or on-line repair information availability.</li> <li>Is any related Service Bulletins available?</li> </ul>	Yes	Perform repair or diagnosis according to the available Service Bulletins. <ul style="list-style-type: none"> <li>If the vehicle is not repaired, go to the next step.</li> </ul>
		No	Go to the next step.
3	<b>VERIFY RELATED PENDING CODE OR STORED DTCs</b> <ul style="list-style-type: none"> <li>Turn the ignition switch off then to the ON position (Engine off).</li> <li>Verify related pending code or</li> </ul>	Yes	Go to the appropriate DTC troubleshooting. (See <b><u>DTC TABLE [MZI-3.5]</u></b> .)

## 2007 Mazda CX-9 Grand Touring

2007 ENGINE PERFORMANCE On-Board Diagnostic (MZI-3.5) - CX-9

	<p>stored DTCs.</p> <ul style="list-style-type: none"> <li>• Is other DTCs present?</li> </ul>	No	Go to the next step.
4	<p><b>INSPECT FOR CORRECT PCM OPERATION</b></p> <ul style="list-style-type: none"> <li>• Disconnect all the PCM connectors.</li> <li>• Visually inspect for: <ul style="list-style-type: none"> <li>○ Pushed out pins</li> <li>○ Corrosion</li> </ul> </li> <li>• Connect all the PCM connectors and verify that they seat correctly.</li> <li>• Retrieve DTCs using the M-MDS.</li> <li>• Is the PENDING CODE for this DTC present?</li> </ul>	Yes	Replace the PCM, then go to the next step. (see <b><u>PCM REMOVAL/INSTALLATION [MZI-3.5]</u></b> .)
		No	Go to the next step.
5	<p><b>VERIFY TROUBLESHOOTING OF DTC P061B HAS BEEN COMPLETED</b></p> <ul style="list-style-type: none"> <li>• Verify that all disconnected connectors are reconnected.</li> <li>• Turn the ignition switch to the ON position (Engine off).</li> <li>• Clear the DTC from the PCM memory using the M-MDS.</li> <li>• Perform the "KOEO and KOER self-test".</li> </ul> <p>(See <b><u>KOEO/KOER SELF TEST [MZI-3.5]</u></b>.)</p> <ul style="list-style-type: none"> <li>• Retrieve DTCs using the M-MDS.</li> <li>• Is the PENDING CODE for this DTC present?</li> </ul>	Yes	Replace the PCM, then go to the next step. (see <b><u>PCM REMOVAL/INSTALLATION [MZI-3.5]</u></b> .)
		No	Go to the next step.
6	<p><b>VERIFY AFTER REPAIR PROCEDURE.</b></p> <ul style="list-style-type: none"> <li>• Perform the "AFTER REPAIR PROCEDURE".</li> </ul> <p>(See <b><u>AFTER REPAIR PROCEDURE [MZI-3.5]</u></b>.)</p>	Yes	Go to the applicable DTC inspection. (See <b><u>DTC TABLE [MZI-3.5]</u></b> .)
		No	Troubleshooting completed.

## 2007 Mazda CX-9 Grand Touring

2007 ENGINE PERFORMANCE On-Board Diagnostic (MZI-3.5) - CX-9

- Are any DTCs present?

### DTC P061C [MZI-3.5]

#### DTC P061C (MZI-3.5) DETECTION CONDITION AND POSSIBLE CAUSES

DTC P061C	Internal control module engine RPM performance
<b>DETECTION CONDITION</b>	<ul style="list-style-type: none"><li>• Indicates that a calculation error occurred in the PCM.</li></ul>
<b>POSSIBLE CAUSE</b>	<ul style="list-style-type: none"><li>• CKP sensor circuit is open or short.</li><li>• CKP sensor circuit intermittent</li><li>• CKP sensor malfunction</li><li>• CMP sensor circuit is open or short.</li><li>• CMP sensor circuit intermittent</li><li>• CMP sensor malfunction</li><li>• PCM malfunction</li></ul>

#### DIAGNOSTIC PROCEDURE

##### DTC P061C (MZI-3.5) DIAGNOSTIC PROCEDURE

STEP	INSPECTION		ACTION
1	<b>VERIFY FREEZE FRAME DATA HAS BEEN RECORDED</b> <ul style="list-style-type: none"><li>• Has FREEZE FRAME DATA been recorded?</li></ul>	Yes	Go to the next step.
		No	Record FREEZE FRAME DATA on the repair order, then go to the next step.
2	<b>VERIFY RELATED REPAIR INFORMATION AVAILABILITY</b> <ul style="list-style-type: none"><li>• Verify related Service Bulletins and/or on-line repair information availability.</li><li>• Is any related Service Bulletins available?</li></ul>	Yes	Perform repair or diagnosis according to the available Service Bulletins. <ul style="list-style-type: none"><li>• If the vehicle is not repaired, go to the next step.</li></ul>
		No	Go to the next step.
3	<b>VERIFY RELATED PENDING CODE OR STORED DTCs</b> <ul style="list-style-type: none"><li>• Turn the ignition switch off then to the ON position (Engine off).</li><li>• Verify related pending code or stored DTCs.</li><li>• Are other DTCs present?</li></ul>	Yes	Go to the appropriate DTC troubleshooting. (See <b>DTC TABLE [MZI-3.5].</b> )
		No	Go to the next step.
4	<b>INSPECT CKP SENSOR SIGNAL</b>	Yes	Go to the next step.



## 2007 Mazda CX-9 Grand Touring

2007 ENGINE PERFORMANCE On-Board Diagnostic (MZI-3.5) - CX-9

<p><b>SENT TO PCM</b></p> <p><b>NOTE:</b></p> <ul style="list-style-type: none"> <li>• <b>The battery should be fully charged and the starting system should be functioning properly.</b></li> <li>• Disable the inertia switch.</li> <li>• Turn the ignition switch to the ON position (Engine off).</li> <li>• Access the PCM and monitor the RPM PID.</li> <li>• Crank the engine.</li> <li>• Is the RPM greater than 150 rpm?</li> </ul>	<p>No</p>	<p>Inspect the CKP sensor or related harness. Repair or replace suspected part, then go to the next step.</p>
<p>5 <b>INSPECT FOR CORRECT PCM OPERATION</b></p> <ul style="list-style-type: none"> <li>• Disconnect all the PCM connectors.</li> <li>• Visually inspect for: <ul style="list-style-type: none"> <li>○ Pushed out pins</li> <li>○ Corrosion</li> </ul> </li> <li>• Connect all the PCM connectors and verify that they seat correctly.</li> <li>• Retrieve DTCs using the M-MDS.</li> <li>• Is the PENDING CODE for this DTC present?</li> </ul>	<p>Yes</p>	<p>Replace the PCM, then go to the next step. (see <b><u>PCM REMOVAL/INSTALLATION [MZI-3.5]</u></b> .)</p>
	<p>No</p>	<p>Go to the next step.</p>
<p>6 <b>VERIFY TROUBLESHOOTING OF DTC P061C HAS BEEN COMPLETED</b></p> <ul style="list-style-type: none"> <li>• Verify that all disconnected connectors are reconnected.</li> <li>• Turn the ignition switch to the ON position (Engine off).</li> <li>• Clear the DTC from the PCM memory using the M-MDS.</li> <li>• Perform the "KOEO and KOER self-test".</li> </ul> <p>(See <b><u>KOEO/KOER SELF TEST [MZI-3.5]</u></b>.)</p>	<p>Yes</p>	<p>Replace the PCM, then go to the next step. (See <b><u>PCM REMOVAL/INSTALLATION [MZI-3.5]</u></b> .)</p>

## 2007 Mazda CX-9 Grand Touring

2007 ENGINE PERFORMANCE On-Board Diagnostic (MZI-3.5) - CX-9

	<ul style="list-style-type: none"> <li>Retrieve the DTCs using the M-MDS.</li> <li>Is the PENDING CODE for this DTC present?</li> </ul>	No	Go to the next step.
7	<p><b>VERIFY AFTER REPAIR PROCEDURE.</b></p> <ul style="list-style-type: none"> <li>Perform the "AFTER REPAIR PROCEDURE".</li> </ul> <p>(See <b>AFTER REPAIR PROCEDURE [MZI-3.5].</b>)</p> <ul style="list-style-type: none"> <li>Are any DTCs present?</li> </ul>	Yes	Go to the applicable DTC inspection. (See <b>DTC TABLE [MZI-3.5].</b> )
		No	Troubleshooting completed.

### DTC P061F [MZI-3.5]

#### DTC P061F (MZI-3.5) DETECTION CONDITION AND POSSIBLE CAUSES

<b>DTC P061F</b>	<b>Internal control module throttle actuator controller performance</b>
<b>DETECTION CONDITION</b>	<ul style="list-style-type: none"> <li>Indicates that a calculation error occurred in the PCM.</li> </ul>
<b>POSSIBLE CAUSE</b>	<p><b>NOTE:</b></p> <ul style="list-style-type: none"> <li>This DTC is an informational DTC and may be set in combination with a number of other DTCs which are causing the FMEM. Diagnose other DTCs first.</li> </ul>

#### DIAGNOSTIC PROCEDURE

#### DTC P061F (MZI-3.5) DIAGNOSTIC PROCEDURE

STEP	INSPECTION		ACTION
1	<p><b>VERIFY FREEZE FRAME DATA HAS BEEN RECORDED</b></p> <ul style="list-style-type: none"> <li>Has FREEZE FRAME DATA been recorded?</li> </ul>	Yes	Go to the next step.
		No	Record FREEZE FRAME DATA on the repair order, then go to the next step.
2	<p><b>VERIFY RELATED REPAIR INFORMATION AVAILABILITY</b></p> <ul style="list-style-type: none"> <li>Verify related Service Bulletins and/or on-line repair information availability.</li> <li>Is any related Service Bulletins available?</li> </ul>	Yes	Perform repair or diagnosis according to the available Service Bulletins. <ul style="list-style-type: none"> <li>If the vehicle is not repaired, go to the next step.</li> </ul>
		No	Go to the next step.
3	<b>VERIFY RELATED PENDING</b>	Yes	Go to the appropriate DTC

## 2007 Mazda CX-9 Grand Touring

2007 ENGINE PERFORMANCE On-Board Diagnostic (MZI-3.5) - CX-9

	<p><b>CODE OR STORED DTCs</b></p> <ul style="list-style-type: none"> <li>• Turn the ignition switch off then to the ON position (Engine off).</li> <li>• Verify related pending code or stored DTCs.</li> <li>• Is other DTCs present?</li> </ul>		<p>troubleshooting. (See <b><u>DTC TABLE [MZI-3.5]</u></b>.)</p>
		No	Go to the next step.
4	<p><b>INSPECT FOR CORRECT PCM OPERATION</b></p> <ul style="list-style-type: none"> <li>• Disconnect all the PCM connectors.</li> <li>• Visually inspect for: <ul style="list-style-type: none"> <li>○ Pushed out pins</li> <li>○ Corrosion</li> </ul> </li> <li>• Connect all the PCM connectors and verify that they seat correctly.</li> <li>• Retrieve DTCs using the M-MDS.</li> <li>• Is the PENDING CODE for this DTC present?</li> </ul>	Yes	<p>Replace the PCM, then go to the next step. (see <b><u>PCM REMOVAL/INSTALLATION [MZI-3.5]</u></b> .)</p>
		No	Go to the next step.
5	<p><b>VERIFY TROUBLESHOOTING OF DTC P061F HAS BEEN COMPLETED</b></p> <ul style="list-style-type: none"> <li>• Verify that all disconnected connectors are reconnected.</li> <li>• Turn the ignition switch to the ON position (Engine off).</li> <li>• Clear the DTC from the PCM memory using the M-MDS.</li> <li>• Perform the "KOEO and KOER self-test".</li> <li>• Retrieve DTCs using the M-MDS.</li> <li>• Is the PENDING CODE for this DTC present?</li> </ul>	Yes	<p>Replace the PCM, then go to the next step. (see <b><u>PCM REMOVAL/INSTALLATION [MZI-3.5]</u></b> .)</p>
		No	Go to the next step.
6	<p><b>VERIFY AFTER REPAIR PROCEDURE.</b></p> <ul style="list-style-type: none"> <li>• Perform the "AFTER REPAIR PROCEDURE".</li> </ul> <p>(See <b><u>AFTER REPAIR PROCEDURE [MZI-3.5]</u></b>.)</p>	Yes	<p>Go to the applicable DTC inspection. (See <b><u>DTC TABLE [MZI-3.5]</u></b>.)</p>
		No	Troubleshooting completed.

## 2007 Mazda CX-9 Grand Touring

2007 ENGINE PERFORMANCE On-Board Diagnostic (MZI-3.5) - CX-9

- Are any DTCs present?

### DTC P0620 [MZI-3.5]

#### DTC P0620 (MZI-3.5) DETECTION CONDITION AND POSSIBLE CAUSES

DTC P0620	Generator control circuit
<b>DETECTION CONDITION</b>	<ul style="list-style-type: none"><li>• The PCM reads the generator and sends a DTC through the network when the generator indicates a concern.</li></ul>
<b>POSSIBLE CAUSE</b>	<ul style="list-style-type: none"><li>• Drive belt misadjustment</li><li>• Generator malfunction</li><li>• Open circuit between generator terminal LI and PCM terminal 2AG</li><li>• Open circuit between generator terminal B and battery positive terminal</li><li>• Short to ground between generator terminal LI and PCM terminal 2AG</li><li>• Short to power supply between generator terminal LI and PCM terminal 2AG</li><li>• Connector or terminal malfunction</li><li>• PCM malfunction</li></ul>

## 2007 Mazda CX-9 Grand Touring

2007 ENGINE PERFORMANCE On-Board Diagnostic (MZI-3.5) - CX-9

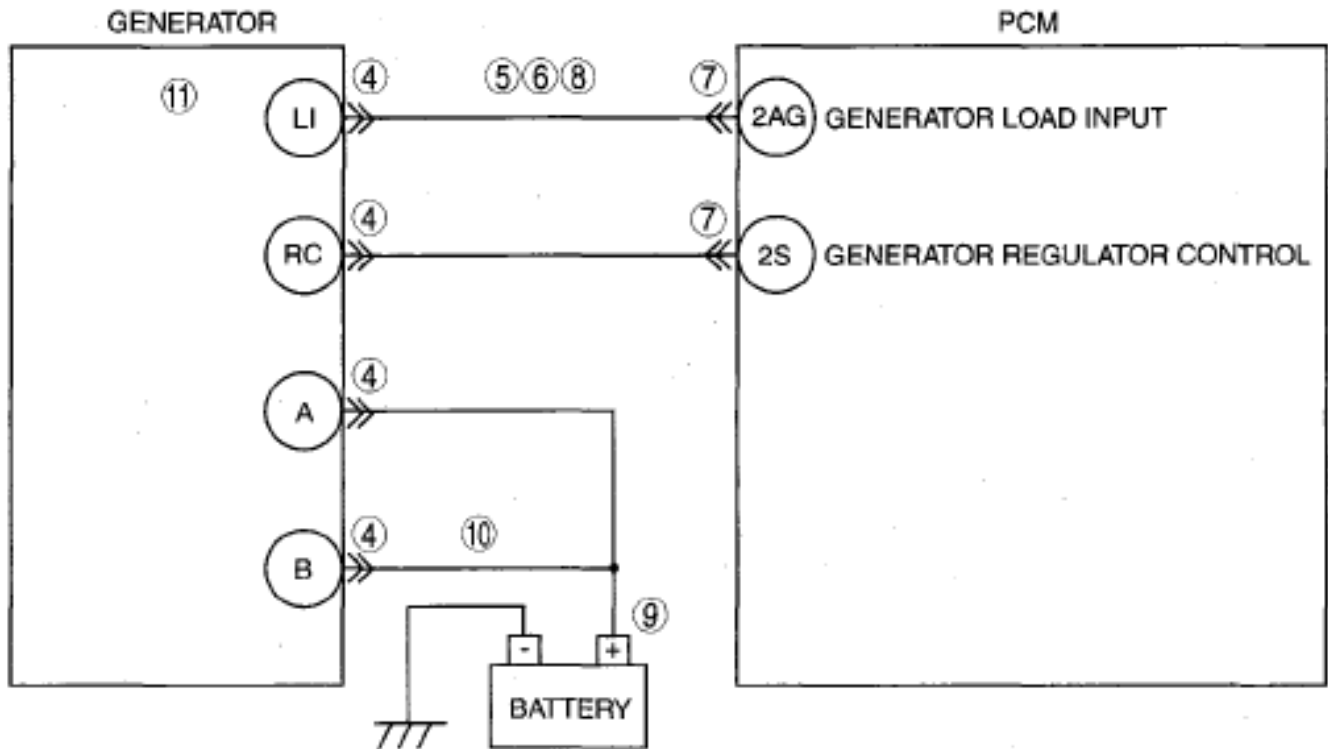

**GENERATOR WIRING HARNESS-SIDE CONNECTOR**

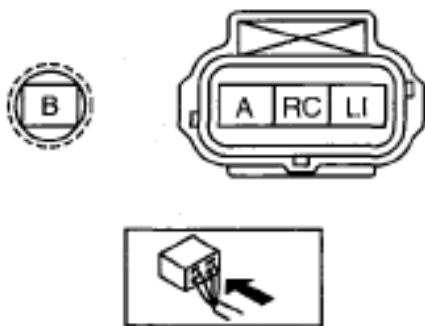

**PCM WIRING HARNESS-SIDE CONNECTOR**

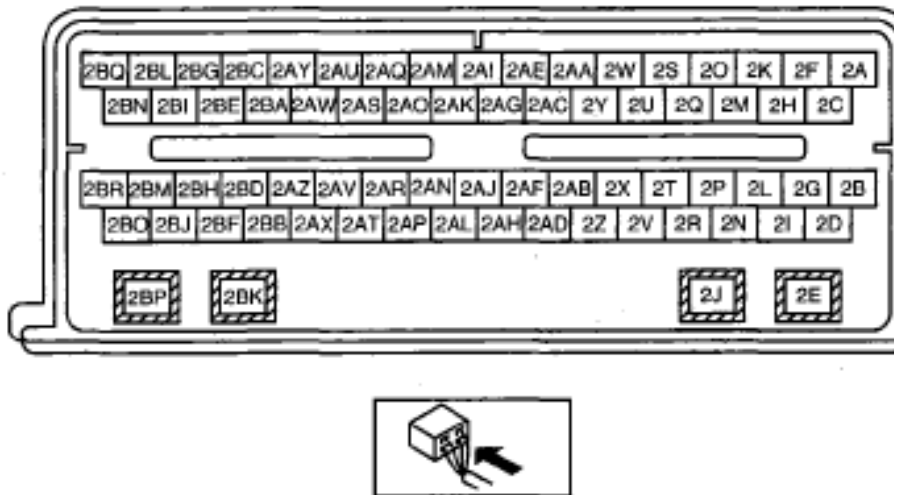

### DIAGNOSTIC PROCEDURE

#### DTC P0620 (MZI-3.5) DIAGNOSTIC PROCEDURE

STEP	INSPECTION		ACTION
1	VERIFY FREEZE FRAME DATA HAS BEEN RECORDED	Yes	Go to the next step.

## 2007 Mazda CX-9 Grand Touring

2007 ENGINE PERFORMANCE On-Board Diagnostic (MZI-3.5) - CX-9

	<ul style="list-style-type: none"> <li>Has FREEZE FRAME DATA been recorded?</li> </ul>	No	Record FREEZE FRAME DATA on the repair order, then go to the next step.
2	<b>VERIFY RELATED REPAIR INFORMATION AVAILABILITY</b> <ul style="list-style-type: none"> <li>Verify related Service Bulletins and/or on-line repair information availability.</li> <li>Is any related Service Bulletins available?</li> </ul>	Yes	Perform repair or diagnosis according to the available Service Bulletins. <ul style="list-style-type: none"> <li>If the vehicle is not repaired, go to the next step.</li> </ul>
		No	Go to the next step.
3	<b>INSPECT DRIVE BELT CONDITION</b> <ul style="list-style-type: none"> <li>Verify that drive belt auto tensioner indicator mark does not exceed limit.</li> <li>Is drive belt normal?</li> </ul>	Yes	Go to the next step.
		No	Replace and/or adjust drive belt, then go to Step 12. (see <b><u>DRIVE BELT INSPECTION [MZI-3.5]</u></b> .)
4	<b>INSPECT GENERATOR TERMINAL FOR POOR INSTALLATION</b> <ul style="list-style-type: none"> <li>Turn the engine switch off.</li> <li>Inspect generator terminal B for looseness.</li> <li>Are there any malfunction?</li> </ul>	Yes	Connect generator terminal B correctly, then go to Step 12.
		No	Go to the next step.
5	<b>INSPECT GENERATOR CIRCUIT FOR SHORT TO POWER SUPPLY</b> <ul style="list-style-type: none"> <li>Turn the ignition switch to the ON position (Engine off).</li> <li>Measure voltage between generator terminal LI (wiring harness-side) and body ground.</li> <li>Is voltage <b>B+</b>?</li> </ul>	Yes	Repair or replace suspected part, then go to Step 12.
		No	Go to the next step.
6	<b>INSPECT GENERATOR CIRCUIT FOR SHORT TO GROUND</b> <ul style="list-style-type: none"> <li>Inspect for continuity between generator terminal LI (wiring harness-side) and body ground.</li> <li>Is there continuity?</li> </ul>	Yes	Repair or replace suspected part, then go to the next step.
		No	Go to the next step.
7	<b>INSPECT PCM CONNECTOR FOR POOR CONNECTION</b>	Yes	Repair or replace suspected part, then go to Step 12.

## 2007 Mazda CX-9 Grand Touring

2007 ENGINE PERFORMANCE On-Board Diagnostic (MZI-3.5) - CX-9

	<ul style="list-style-type: none"> <li>• Turn the engine switch off.</li> <li>• Inspect for poor connection (such as damaged/pulled-out terminals, corrosion).</li> <li>• Are there any malfunction?</li> </ul>	No	Go to the next step.
8	<b>INSPECT GENERATOR CIRCUIT FOR OPEN CIRCUIT</b> <ul style="list-style-type: none"> <li>• Inspect for continuity between generator terminal LI (wiring harness-side) and PCM terminal 2AG (wiring harness-side)</li> <li>• Is there continuity?</li> </ul>	Yes	Go to the next step.
		No	Repair or replace suspected part, then go to Step 12.
9	<b>INSPECT BATTERY POSITIVE TERMINAL FOR POOR INSTALLATION</b> <ul style="list-style-type: none"> <li>• Turn the engine switch off.</li> <li>• Inspect the battery positive terminal for looseness.</li> <li>• Is there any malfunction?</li> </ul>	Yes	Connect the battery positive terminal correctly, then go to Step 12.
		No	Go to the next step.
10	<b>INSPECT GENERATOR CIRCUIT FOR OPEN CIRCUIT</b> <ul style="list-style-type: none"> <li>• Inspect continuity between generator terminal B (wiring harness-side) and battery positive terminal (wiring harness-side).</li> <li>• Is there continuity?</li> </ul>	Yes	Go to the next step.
		No	Repair or replace suspected part, then go to Step 12.
11	<b>INSPECT GENERATOR</b> <ul style="list-style-type: none"> <li>• Inspect the generator.</li> </ul> <p>(see <b><u>GENERATOR INSPECTION [MZI-3.5]</u></b> .)</p> <ul style="list-style-type: none"> <li>• Is there any malfunction?</li> </ul>	Yes	Replace the generator, then go to the next step. (see <b><u>GENERATOR REMOVAL/INSTALLATION [MZI-3.5]</u></b> .)
		No	Go to the next step.
12	<b>VERIFY TROUBLESHOOTING OF DTC P0620 HAS BEEN COMPLETED</b> <ul style="list-style-type: none"> <li>• Verify that all disconnected connectors reconnected.</li> <li>• Clear the DTC from the PCM</li> </ul>	Yes	Replace the PCM, then go to the next step. (see <b><u>PCM REMOVAL/INSTALLATION [MZI-3.5]</u></b> .)

## 2007 Mazda CX-9 Grand Touring

2007 ENGINE PERFORMANCE On-Board Diagnostic (MZI-3.5) - CX-9

	<p>memory using the M-MDS.</p> <ul style="list-style-type: none"> <li>Perform the "KOEO or KOER self-test" using the M-MDS.</li> </ul> <p>(See <b><u>KOEO/KOER SELF TEST [MZI-3.5].</u></b>)</p> <ul style="list-style-type: none"> <li>Is the PENDING CODE for the DTC present?</li> </ul>	No	Go to the next step.
13	<p><b>VERIFY AFTER REPAIR PROCEDURE.</b></p> <ul style="list-style-type: none"> <li>Perform the "AFTER REPAIR PROCEDURE".</li> </ul> <p>(See <b><u>AFTER REPAIR PROCEDURE [MZI-3.5].</u></b>)</p> <ul style="list-style-type: none"> <li>Are any DTCs present?</li> </ul>	Yes	Go to the applicable DTC inspection. (See <b><u>DTC TABLE [MZI-3.5].</u></b> )
		No	Troubleshooting completed.

### DTC P0625 [MZI-3.5]

#### DTC P0625 (MZI-3.5) DETECTION CONDITION AND POSSIBLE CAUSES

<b>DTC P0625</b>	<b>Generator field terminal circuit low</b>
<b>DETECTION CONDITION</b>	<ul style="list-style-type: none"> <li>The PCM monitors generator load from the generator/regulator in the form of frequency. The concern indicates the input is lower than the load should be in normal operation. The load input could be low when no generator output exists.</li> </ul>
<b>POSSIBLE CAUSE</b>	<ul style="list-style-type: none"> <li>Drive belt damaged</li> <li>Generator malfunction</li> <li>Short to ground between generator terminal RC and PCM terminal 2S</li> <li>Short to ground between generator terminal LI and PCM terminal 2AG</li> <li>Open circuit between terminal B and battery positive terminal</li> <li>Low system voltage</li> <li>Connector or terminal malfunction</li> </ul>



# 2007 Mazda CX-9 Grand Touring

2007 ENGINE PERFORMANCE On-Board Diagnostic (MZI-3.5) - CX-9

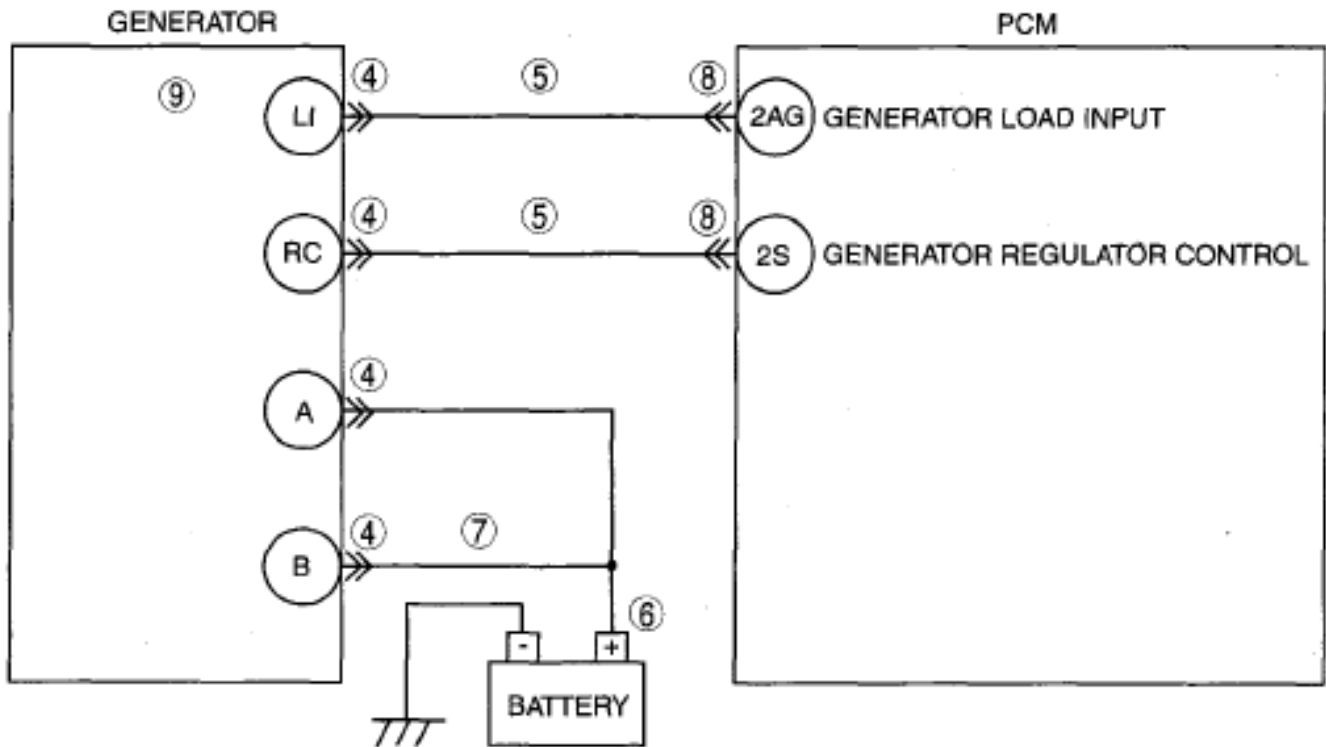

**GENERATOR WIRING HARNESS-SIDE CONNECTOR**

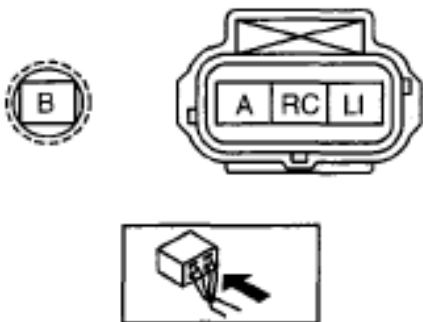

**PCM WIRING HARNESS-SIDE CONNECTOR**

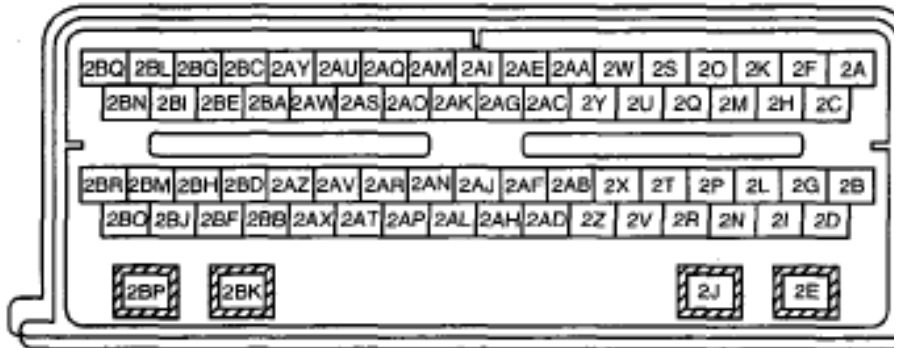

## DIAGNOSTIC PROCEDURE

### DTC P0625 (MZI-3.5) DIAGNOSTIC PROCEDURE

STEP	INSPECTION		ACTION
1	VERIFY FREEZE FRAME DATA HAS BEEN RECORDED	Yes	Go to the next step.

## 2007 Mazda CX-9 Grand Touring

2007 ENGINE PERFORMANCE On-Board Diagnostic (MZI-3.5) - CX-9

	<ul style="list-style-type: none"> <li>Has FREEZE FRAME DATA been recorded?</li> </ul>	No	Record FREEZE FRAME DATA on the repair order, then go to the next step.
2	<b>VERIFY RELATED REPAIR INFORMATION AVAILABILITY</b> <ul style="list-style-type: none"> <li>Verify related Service Bulletins and/or on-line repair information availability.</li> <li>Is any related Service Bulletins available?</li> </ul>	Yes	Perform repair or diagnosis according to the available Service Bulletins. <ul style="list-style-type: none"> <li>If the vehicle is not repaired, go to the next step.</li> </ul>
		No	Go to the next step.
3	<b>INSPECT DRIVE BELT DAMAGED</b> <ul style="list-style-type: none"> <li>Verify inspect the drive belt for damage.</li> <li>Is the drive belt normal?</li> </ul>	Yes	Go to the next step.
		No	Replace the drive belt, then go to Step 10. (see <b><u>DRIVE BELT INSPECTION [MZI-3.5]</u></b> .)
4	<b>INSPECT GENERATOR TERMINAL FOR POOR INSTALLATION</b> <ul style="list-style-type: none"> <li>Turn the engine switch off.</li> <li>Inspect generator terminal B for looseness.</li> <li>Are there any malfunction?</li> </ul>	Yes	Connect generator terminal B correctly, then go to Step 10.
		No	Go to the next step.
5	<b>INSPECT GENERATOR CIRCUIT FOR SHORT TO GROUND</b> <ul style="list-style-type: none"> <li>Inspect for continuity between the following terminal:               <ul style="list-style-type: none"> <li>Generator terminal RC (wiring harness-side) and body ground.</li> <li>Generator terminal LI (wiring harness-side) and body ground.</li> </ul> </li> <li>Are there continuity?</li> </ul>	Yes	Repair or replace suspected part, then go to Step 10.
		No	Go to the next step.
6	<b>INSPECT BATTERY POSITIVE TERMINAL FOR POOR INSTALLATION</b> <ul style="list-style-type: none"> <li>Turn the engine switch off.</li> <li>Inspect the battery positive terminal for looseness.</li> <li>Is there any malfunction?</li> </ul>	Yes	Connect the battery positive terminal correctly, then go to Step 10.
		No	Go to the next step.

## 2007 Mazda CX-9 Grand Touring

2007 ENGINE PERFORMANCE On-Board Diagnostic (MZI-3.5) - CX-9

7	<p><b>INSPECT GENERATOR CIRCUIT FOR OPEN CIRCUIT</b></p> <ul style="list-style-type: none"> <li>• Inspect the continuity between generator terminal B (wiring harness-side) and battery positive terminal (wiring harness-side)</li> <li>• Is there continuity?</li> </ul>	Yes	Go to the next step.
		No	Repair or replace suspected part, then go to Step 10.
8	<p><b>INSPECT PCM CONNECTOR FOR POOR CONNECTION</b></p> <ul style="list-style-type: none"> <li>• Turn the engine switch off.</li> <li>• Inspect for poor connection (such as damaged/pulled-out terminals, corrosion).</li> <li>• Are there any malfunction?</li> </ul>	Yes	Repair or replace suspected part, then go to Step 10.
		No	Go to the next step.
9	<p><b>INSPECT GENERATOR</b></p> <ul style="list-style-type: none"> <li>• Inspect the generator.</li> </ul> <p>(see <b><u>GENERATOR INSPECTION [MZI-3.5]</u></b> .)</p> <ul style="list-style-type: none"> <li>• Is there any malfunction?</li> </ul>	Yes	Replace the generator, then go to Step 10. (see <b><u>GENERATOR REMOVAL/INSTALLATION [MZI-3.5]</u></b> .)
		No	Go to the next step.
10	<p><b>VERIFY TROUBLESHOOTING OF DTC P0625 HAS BEEN COMPLETED</b></p> <ul style="list-style-type: none"> <li>• Verify that all disconnected connectors reconnected.</li> <li>• Clear the DTC from the PCM memory using the M-MDS.</li> <li>• Perform the "KOEO or KOER self-test" using the M-MDS.</li> </ul> <p>(See <b><u>KOEO/KOER SELF TEST [MZI-3 51]</u></b>.)</p> <ul style="list-style-type: none"> <li>• Is the PENDING CODE for the DTC present?</li> </ul>	Yes	Replace the PCM, then go to the next step. (see <b><u>PCM REMOVAL/INSTALLATION [MZI-3.5]</u></b> .)
		No	Go to the next step.
11	<p><b>VERIFY AFTER REPAIR PROCEDURE</b></p> <ul style="list-style-type: none"> <li>• Perform the "AFTER REPAIR PROCEDURE".</li> </ul>	Yes	Go to the applicable DTC inspection. (See <b><u>DTC TABLE [MZI-3.5]</u></b> .)

## 2007 Mazda CX-9 Grand Touring

2007 ENGINE PERFORMANCE On-Board Diagnostic (MZI-3.5) - CX-9

<p>(See <b><u>AFTER REPAIR PROCEDURE [MZI-3.5]</u></b>.)</p> <ul style="list-style-type: none"><li>• Are any DTCs present?</li></ul>	No	Troubleshooting completed.
--	----	----------------------------

### DTC P0626 [MZI-3.5]

#### DTC P0626 (MZI-3.5) DETECTION CONDITION AND POSSIBLE CAUSES

DTC P0626	Generator field terminal circuit high
<b>DETECTION CONDITION</b>	<ul style="list-style-type: none"><li>• The PCM monitors generator load from the generator/regulator in the form of frequency. The concern indicates the input is higher than the load should be in normal operation. The load input could be high when a battery short to ground exists.</li></ul>
<b>POSSIBLE CAUSE</b>	<ul style="list-style-type: none"><li>• Open circuit in wiring harness between generator terminal RC and PCM terminal</li><li>• Short to power supply between generator terminal RC and PCM terminal 2S</li><li>• Short to power supply between generator terminal LI and PCM terminal 2AG</li><li>• Connector or terminal malfunction</li></ul>

# 2007 Mazda CX-9 Grand Touring

2007 ENGINE PERFORMANCE On-Board Diagnostic (MZI-3.5) - CX-9

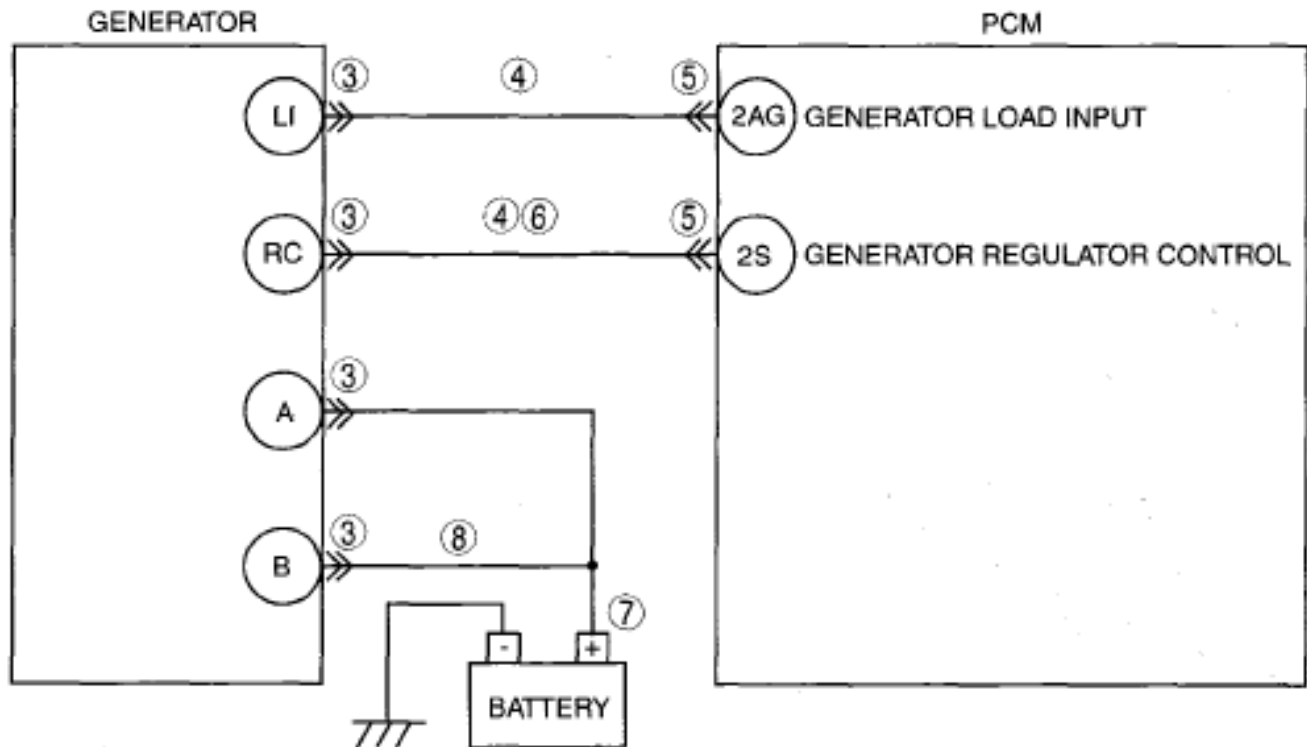

GENERATOR WIRING HARNESS-SIDE CONNECTOR

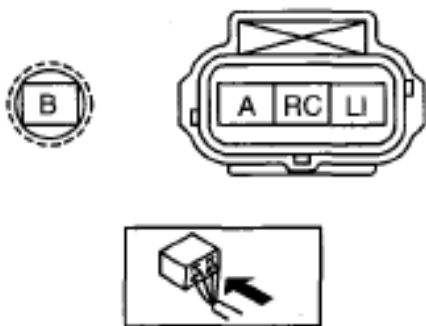

PCM WIRING HARNESS-SIDE CONNECTOR

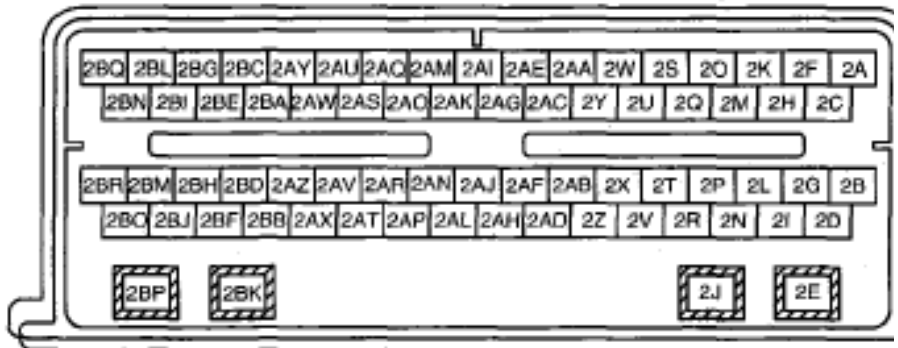

## DIAGNOSTIC PROCEDURE

### DTC P0626 (MZI-3.5) DIAGNOSTIC PROCEDURE

STEP	INSPECTION		ACTION
1	VERIFY FREEZE FRAME DATA HAS BEEN RECORDED	Yes	Go to the next step.

## 2007 Mazda CX-9 Grand Touring

2007 ENGINE PERFORMANCE On-Board Diagnostic (MZI-3.5) - CX-9

	<ul style="list-style-type: none"> <li>Has FREEZE FRAME DATA been recorded?</li> </ul>	No	Record FREEZE FRAME DATA on the repair order, then go to the next step.
2	<b>VERIFY RELATED REPAIR INFORMATION AVAILABILITY</b> <ul style="list-style-type: none"> <li>Verify related Service Bulletins and/or on-line repair information availability.</li> <li>Is any related Service Bulletins available?</li> </ul>	Yes	Perform repair or diagnosis according to the available Service Bulletins. <ul style="list-style-type: none"> <li>If the vehicle is not repaired, go to the next step.</li> </ul>
		No	Go to the next step.
3	<b>INSPECT GENERATOR TERMINAL FOR POOR INSTALLATION</b> <ul style="list-style-type: none"> <li>Turn the engine switch off.</li> <li>Inspect generator terminal B for looseness.</li> <li>Are there any malfunction?</li> </ul>	Yes	Connect generator terminal B correctly, then go to Step 9.
		No	Go to the next step.
4	<b>INSPECT GENERATOR CIRCUIT FOR SHORT TO POWER SUPPLY</b> <ul style="list-style-type: none"> <li>Turn the ignition switch to the ON position (Engine off).</li> <li>Measure the voltage between the following terminals:               <ul style="list-style-type: none"> <li>Generator terminal RC (wiring harness-side) and body ground.</li> <li>Generator terminal LI (wiring harness-side) and body ground.</li> </ul> </li> <li>Is the voltage B+?</li> </ul>	Yes	Repair or replace suspected part, then go to Step 9.
		No	Go to the next step.
5	<b>INSPECT PCM CONNECTOR FOR POOR CONNECTION</b> <ul style="list-style-type: none"> <li>Turn the engine switch off.</li> <li>Inspect for poor connection (such as damaged/pulled-out terminals, corrosion).</li> <li>Are there any malfunction?</li> </ul>	Yes	Repair or replace suspected part, then go to Step 9.
		No	Go to the next step.
6	<b>INSPECT GENERATOR CIRCUIT FOR OPEN CIRCUIT</b>	Yes	Go to the next step.

## 2007 Mazda CX-9 Grand Touring

2007 ENGINE PERFORMANCE On-Board Diagnostic (MZI-3.5) - CX-9

	<ul style="list-style-type: none"> <li>Inspect for continuity between generator terminal RC (wiring harness-side) and PCM terminal 2S (wiring harness-side).</li> <li>Is there continuity?</li> </ul>	No	Repair or replace suspected part, then go to Step 9.
7	<b>INSPECT BATTERY POSITIVE TERMINAL FOR POOR INSTALLATION</b> <ul style="list-style-type: none"> <li>Turn the engine switch off.</li> <li>Inspect the battery positive terminal for looseness.</li> <li>Is there any malfunction?</li> </ul>	Yes	Connect the battery positive terminal correctly, then go to Step 9.
		No	Go to the next step.
8	<b>INSPECT GENERATOR CIRCUIT FOR OPEN CIRCUIT</b> <ul style="list-style-type: none"> <li>Inspect the continuity between generator terminal B (wiring harness-side) and battery positive terminal (wiring harness-side)</li> <li>Is there continuity?</li> </ul>	Yes	Go to the next step.
		No	Repair or replace suspected part, then go to the next step.
9	<b>VERIFY TROUBLESHOOTING OF DTC P0626 HAS BEEN COMPLETED</b> <ul style="list-style-type: none"> <li>Verify that all disconnected connectors reconnected.</li> <li>Clear the DTC from the PCM memory using the M-MDS.</li> <li>Perform the KOEO or KOER self-test using the M-MDS.</li> </ul> <p>(See <b><u>KOEO/KOER SELF TEST [MZI-3.5].</u></b>)</p> <ul style="list-style-type: none"> <li>Is the PENDING CODE for the DTC present?</li> </ul>	Yes	Replace the PCM, then go to the next step. (see <b><u>PCM REMOVAL/INSTALLATION [MZI-3.5].</u></b> )
		No	Go to the next step.
10	<b>VERIFY AFTER REPAIR PROCEDURE</b> <ul style="list-style-type: none"> <li>Perform the "AFTER REPAIR PROCEDURE".</li> </ul> <p>(See <b><u>AFTER REPAIR</u></b></p>	Yes	Go to the applicable DTC inspection. (See <b><u>DTC TABLE [MZI-3.5].</u></b> )
		No	Troubleshooting completed.

## 2007 Mazda CX-9 Grand Touring

2007 ENGINE PERFORMANCE On-Board Diagnostic (MZI-3.5) - CX-9

### PROCEDURE [MZI-3.5].)

- Are any DTCs present?

## DTC P0642 [MZI-3.5]

### DTC P0642 (MZI-3.5) DETECTION CONDITION AND POSSIBLE CAUSES

<b>DTC P0642</b>	<b>Sensor reference voltage circuit low</b>
<b>DETECTION CONDITION</b>	<ul style="list-style-type: none"><li>• Indicates the reference voltage circuit is lower than reference voltage minimum.</li></ul>
<b>POSSIBLE CAUSE</b>	<ul style="list-style-type: none"><li>• Short to ground between fuel tank pressure sensor terminal C and PCM terminal 1</li><li>• Fuel tank pressure sensor malfunction</li><li>• Connector or terminal malfunction</li></ul>



## 2007 Mazda CX-9 Grand Touring

2007 ENGINE PERFORMANCE On-Board Diagnostic (MZI-3.5) - CX-9

FUEL TANK PRESSURE SENSOR

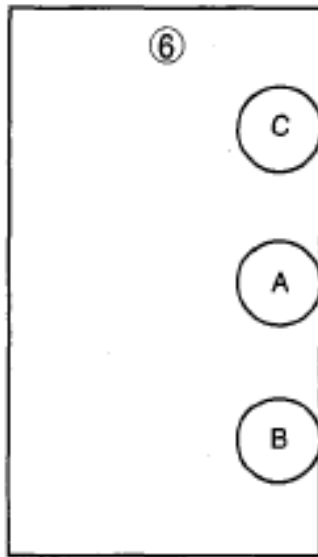

PCM

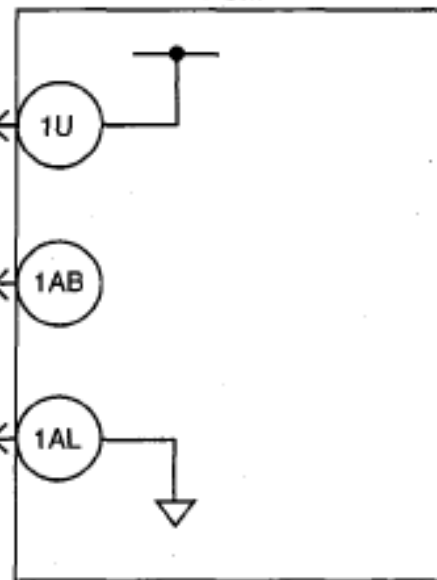

PCM  
WIRING HARNESS-SIDE CONNECTOR

FUEL TANK PRESSURE SENSOR  
WIRING HARNESS-SIDE CONNECTOR

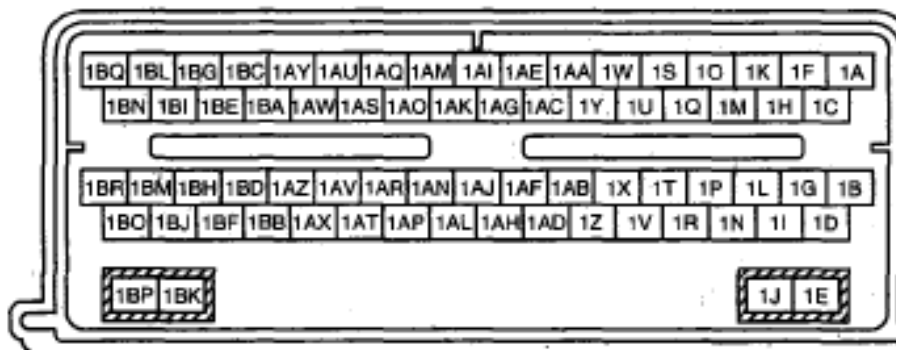

### DIAGNOSTIC PROCEDURE

#### DTC P0642 (MZI-3.5) DIAGNOSTIC PROCEDURE

STEP	INSPECTION		ACTION
1	<b>VERIFY FREEZE FRAME DATA HAS BEEN RECORDED.</b> <ul style="list-style-type: none"> <li>Has FREEZE FRAME DATA been recorded?</li> </ul>	Yes	Go to the next step.
		No	Record FREEZE FRAME DATA on the repair order, then go to the next step.

## 2007 Mazda CX-9 Grand Touring

2007 ENGINE PERFORMANCE On-Board Diagnostic (MZI-3.5) - CX-9

2	<b>VERIFY RELATED REPAIR INFORMATION AVAILABILITY</b> <ul style="list-style-type: none"> <li>• Verify related Service Bulletins and/or on-line repair information availability.</li> <li>• Is any related Service Bulletins available?</li> </ul>	Yes	Perform repair or diagnosis according to the available Service Bulletins. <ul style="list-style-type: none"> <li>• If the vehicle is not repaired, go to the next step.</li> </ul>
		No	Go to the next step.
3	<b>INSPECT FUEL TANK PRESSURE SENSOR CONNECTOR FOR POOR CONNECTION</b> <ul style="list-style-type: none"> <li>• Turn the ignition switch off.</li> <li>• Disconnect the fuel tank pressure sensor connector.</li> <li>• Inspect for poor connection (such as damaged/pulled-out pins, corrosion).</li> <li>• Are there any malfunction?</li> </ul>	Yes	Repair or replace suspected part, then go to Step 7.
		No	Go to the next step.
4	<b>INSPECT PCM CONNECTOR FOR POOR CONNECTION</b> <ul style="list-style-type: none"> <li>• Turn the ignition switch off.</li> <li>• Disconnect the PCM connector.</li> <li>• Inspect for poor connection (such as damaged/pulled-out pins, corrosion).</li> <li>• Are there any malfunction?</li> </ul>	Yes	Repair or replace suspected part, then go to Step 7.
		No	Go to the next step.
5	<b>INSPECT FUEL TANK PRESSURE SENSOR CIRCUIT FOR SHORT TO GROUND</b> <ul style="list-style-type: none"> <li>• Turn the ignition switch off.</li> <li>• Inspect the continuity between fuel tank pressure sensor terminal C (wiring harness-side) and body ground.</li> <li>• Is there continuity?</li> </ul>	Yes	Repair or replace suspected part, then go to Step 7.
		No	Go to the next step.
6	<b>INSPECT FUEL TANK PRESSURE SENSOR</b> <ul style="list-style-type: none"> <li>• Inspect the fuel tank pressure sensor. (see <b><u>FUEL TANK PRESSURE SENSOR</u></b>)</li> </ul>	Yes	Replace the evaporative hose component, then go to the next step. (see <b><u>FUEL TANK REMOVAL/INSTALLATION [MZI-3.5]</u></b> .)

## 2007 Mazda CX-9 Grand Touring

2007 ENGINE PERFORMANCE On-Board Diagnostic (MZI-3.5) - CX-9

	<p style="text-align: center;"><b><u>INSPECTION [MZI-3.5] .)</u></b></p> <ul style="list-style-type: none"> <li>• Is there any malfunction?</li> </ul>	No	Go to the next step.
7	<p><b>VERIFY TROUBLESHOOTING OF DTC P0642 HAS BEEN COMPLETED</b></p> <ul style="list-style-type: none"> <li>• Verify that all disconnected connectors reconnected.</li> <li>• Clear the DTC from the PCM memory using the M-MDS.</li> <li>• Perform the "KOEO or KOER self-test" using the M-MDS.</li> </ul> <p>(See <b><u>KOEO/KOER SELF TEST [MZI-3.5].)</u></b></p> <ul style="list-style-type: none"> <li>• Is the PENDING CODE for the DTC present?</li> </ul>	Yes	Replace the PCM, then go to the next step. (see <b><u>PCM REMOVAL/INSTALLATION [MZI-3.5] .)</u></b>
		No	Go to the next step.
8	<p><b>VERIFY AFTER REPAIR PROCEDURE.</b></p> <ul style="list-style-type: none"> <li>• Perform the "AFTER REPAIR PROCEDURE".</li> </ul> <p>(See <b><u>AFTER REPAIR PROCEDURE [MZI-3.5].)</u></b></p> <ul style="list-style-type: none"> <li>• Are any DTCs present?</li> </ul>	Yes	Go to the applicable DTC inspection. (See <b><u>DTC TABLE [MZI-3.5].)</u></b>
		No	Troubleshooting completed.

### DTC P0643 [MZI-3.5]

#### DTC P0643 (MZI-3.5) DETECTION CONDITION AND POSSIBLE CAUSES

<b>DTC P0643</b>	<b>Sensor reference voltage circuit high</b>
<b>DETECTION CONDITION</b>	<ul style="list-style-type: none"> <li>• Indicates the reference voltage circuit is higher than reference voltage maximum.</li> </ul>
<b>POSSIBLE CAUSE</b>	<ul style="list-style-type: none"> <li>• Short to ground between fuel tank pressure sensor terminal C and PCM terminal 1</li> <li>• Fuel tank pressure sensor malfunction</li> <li>• Connector or terminal malfunction</li> </ul>

## 2007 Mazda CX-9 Grand Touring

2007 ENGINE PERFORMANCE On-Board Diagnostic (MZI-3.5) - CX-9

**FUEL TANK PRESSURE SENSOR**

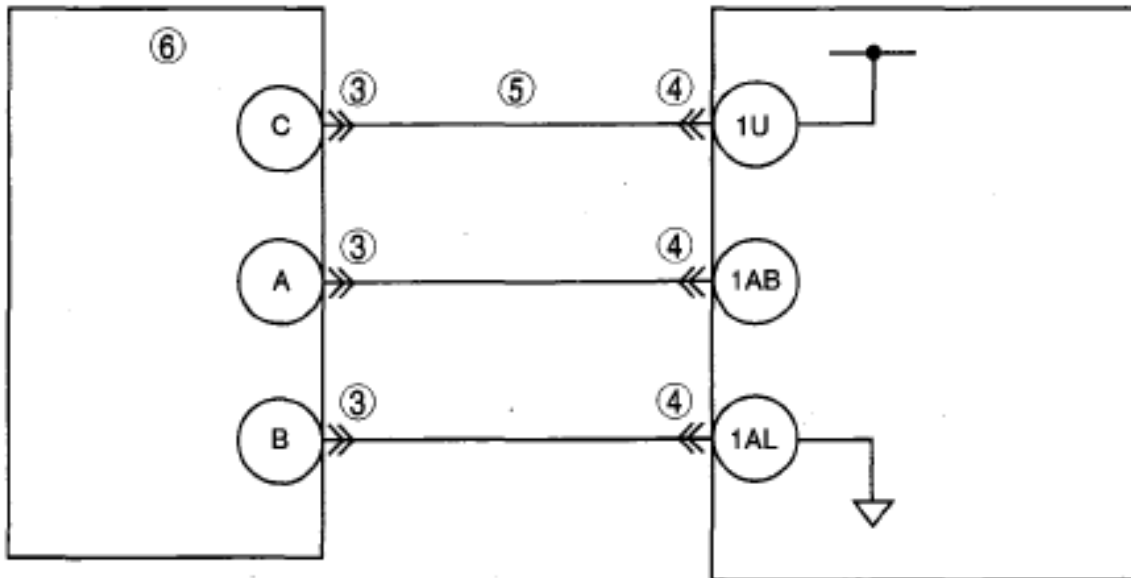

**PCM  
WIRING HARNESS-SIDE CONNECTOR**

**FUEL TANK PRESSURE SENSOR  
WIRING HARNESS-SIDE CONNECTOR**

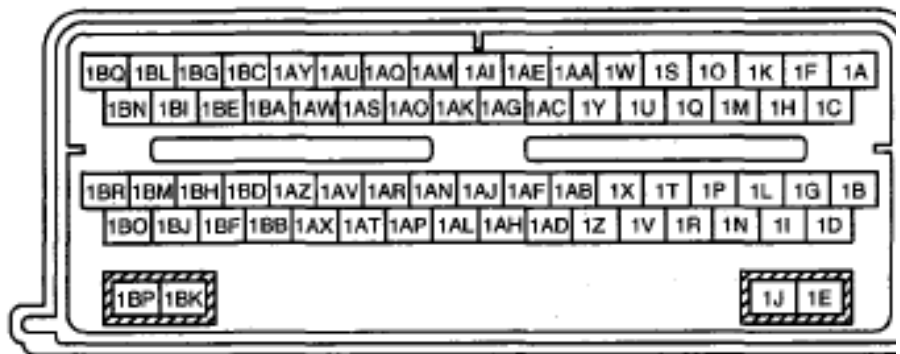

### DIAGNOSTIC PROCEDURE

#### DTC P0643 (MZI-3.5) DIAGNOSTIC PROCEDURE

STEP	INSPECTION	ACTION	
1	<b>VERIFY FREEZE FRAME DATA HAS BEEN RECORDED.</b> <ul style="list-style-type: none"> <li>Has FREEZE FRAME DATA been recorded?</li> </ul>	Yes	Go to the next step.
		No	Record FREEZE FRAME DATA on the repair order, then go to the next step.

## 2007 Mazda CX-9 Grand Touring

2007 ENGINE PERFORMANCE On-Board Diagnostic (MZI-3.5) - CX-9

2	<b>VERIFY RELATED REPAIR INFORMATION AVAILABILITY</b> <ul style="list-style-type: none"> <li>• Verify related Service Bulletins and/or on-line repair information availability.</li> <li>• Is any related Service Bulletins available?</li> </ul>	Yes	Perform repair or diagnosis according to the available Service Bulletins. <ul style="list-style-type: none"> <li>• If the vehicle is not repaired, go to the next step.</li> </ul>
		No	Go to the next step.
3	<b>INSPECT FUEL TANK PRESSURE SENSOR CONNECTOR FOR POOR CONNECTION</b> <ul style="list-style-type: none"> <li>• Turn the ignition switch off.</li> <li>• Disconnect the fuel tank pressure sensor connector.</li> <li>• Inspect for poor connection (such as damaged/pulled-out pins, corrosion).</li> <li>• Are there any malfunction?</li> </ul>	Yes	Repair or replace suspected part, then go to Step 7.
		No	Go to the next step.
4	<b>INSPECT PCM CONNECTOR FOR POOR CONNECTION</b> <ul style="list-style-type: none"> <li>• Turn the ignition switch off.</li> <li>• Disconnect the PCM connector.</li> <li>• Inspect for poor connection (such as damaged/pulled-out pins, corrosion).</li> <li>• Are there any malfunction?</li> </ul>	Yes	Repair or replace suspected part, then go to Step 7.
		No	Go to the next step.
5	<b>INSPECT FUEL TANK PRESSURE SENSOR CIRCUIT FOR SHORT TO POWER SUPPLY</b> <ul style="list-style-type: none"> <li>• Turn the ignition switch to the ON position (Engine off).</li> <li>• Measure the voltage continuity between fuel tank pressure sensor terminal C (wiring harness-side) and body ground.</li> <li>• Is the voltage <b>B+</b> ?</li> </ul>	Yes	Repair or replace suspected part, then go to Step 7.
		No	Go to the next step.
6	<b>INSPECT FUEL TANK PRESSURE SENSOR</b> <ul style="list-style-type: none"> <li>• Inspect the fuel tank pressure sensor.</li> </ul>	Yes	Replace the evaporative hose component, then go to the next step. (see <b><u>FUEL TANK REMOVAL/INSTALLATION [MZI-3.5]</u></b> .)

## 2007 Mazda CX-9 Grand Touring

2007 ENGINE PERFORMANCE On-Board Diagnostic (MZI-3.5) - CX-9

	<p>(see <b><u>FUEL TANK PRESSURE SENSOR INSPECTION [MZI-3.5]</u></b> .)</p> <ul style="list-style-type: none"> <li>• Is there any malfunction?</li> </ul>	No	Go to the next step.
7	<p><b>VERIFY TROUBLESHOOTING OF DTC P0643 HAS BEEN COMPLETED</b></p> <ul style="list-style-type: none"> <li>• Verify that all disconnected connectors reconnected.</li> <li>• Clear the DTC from the PCM memory using the M-MDS.</li> <li>• Perform the "KOEO or KOER self-test" using the M-MDS.</li> </ul> <p>(See <b><u>KOEO/KOER SELF TEST [MZI-3.5]</u></b>.)</p> <ul style="list-style-type: none"> <li>• Is the PENDING CODE for the DTC present?</li> </ul>	Yes	Replace the PCM, then go to the next step. (see <b><u>PCM REMOVAL/INSTALLATION [MZI-3.5]</u></b> .)
		No	Go to the next step.
8	<p><b>VERIFY AFTER REPAIR PROCEDURE.</b></p> <ul style="list-style-type: none"> <li>• Perform the "AFTER REPAIR PROCEDURE".</li> </ul> <p>(See <b><u>AFTER REPAIR PROCEDURE [MZI-3.5]</u></b>.)</p> <ul style="list-style-type: none"> <li>• Are any DTCs present?</li> </ul>	Yes	Go to the applicable DTC inspection. (See <b><u>DTC TABLE [MZI-3.5]</u></b> .)
		No	Troubleshooting completed.

### DTC P0645 [MZI-3.5]

#### DTC P0645 (MZI-3.5) DETECTION CONDITION AND POSSIBLE CAUSES

DTC P0645	A/C relay control circuit
<b>DETECTION CONDITION</b>	<ul style="list-style-type: none"> <li>• Monitors the A/C relay control circuit output from the PCM. The test fails when the PCM grounds the A/C relay control circuit, excessive current draw is detected on the A/C relay control circuit; or, with the A/C relay control circuit not grounded by the PCM, voltage is not detected on the A/C relay control circuit (the PCM expects to detect vehicle power voltage coming through the A/C relay coil to the A/C circuit)</li> </ul>
	<ul style="list-style-type: none"> <li>• A/C relay malfunction</li> <li>• Connector or terminal malfunction</li> <li>• Open circuit in wiring between main relay terminal No.1 D and A/C relay terminal</li> </ul>

## 2007 Mazda CX-9 Grand Touring

2007 ENGINE PERFORMANCE On-Board Diagnostic (MZI-3.5) - CX-9

### POSSIBLE CAUSE

- Open circuit in wiring between A/C relay terminal E and PCM terminal 1N
- Short to ground in wiring between A/C relay terminal E and PCM terminal 1 N
- Short to power supply between A/C relay terminal E and PCM terminal 1 N

# 2007 Mazda CX-9 Grand Touring

2007 ENGINE PERFORMANCE On-Board Diagnostic (MZI-3.5) - CX-9

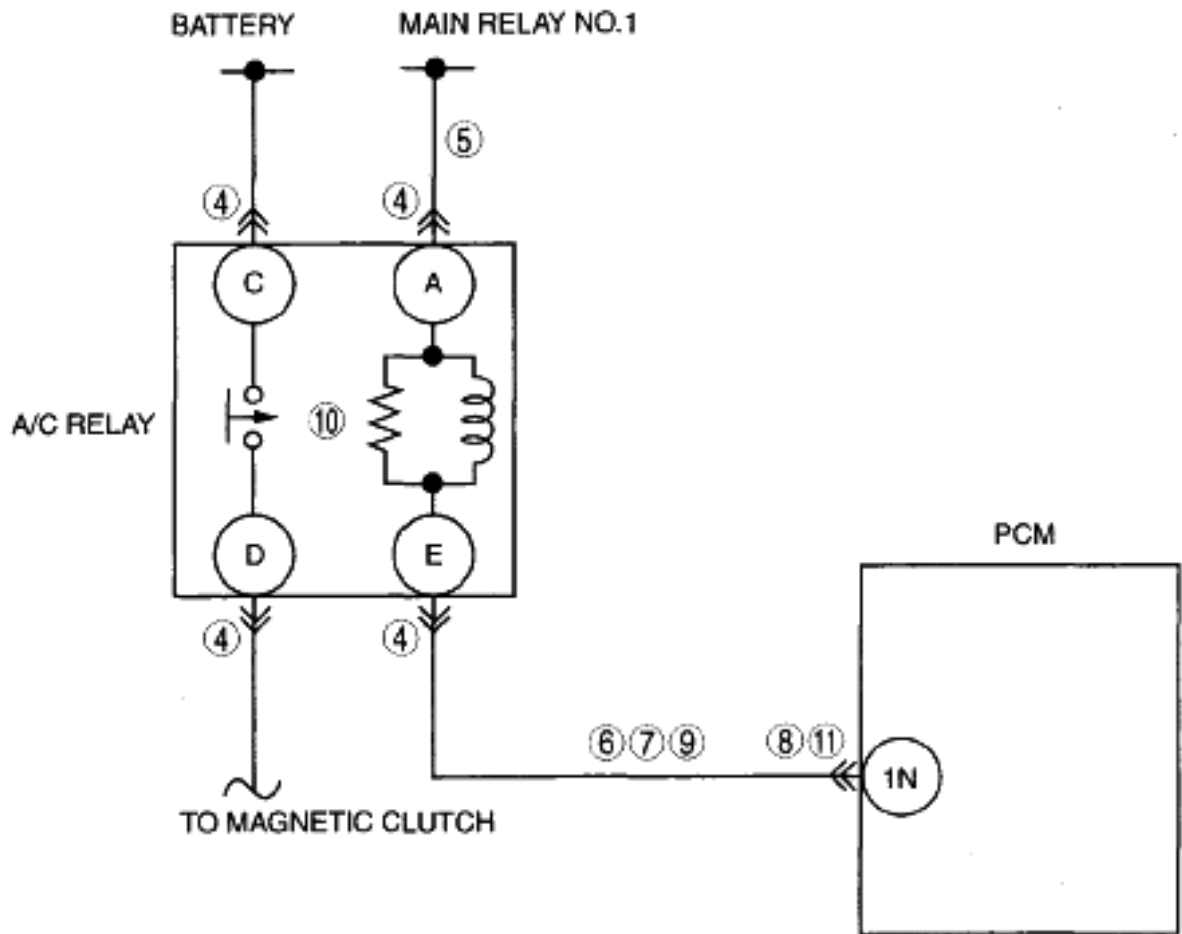

PCM  
WIRING HARNESS-SIDE CONNECTOR

MAIN RELAY NO.1

A/C RELAY

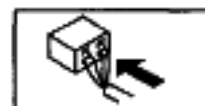
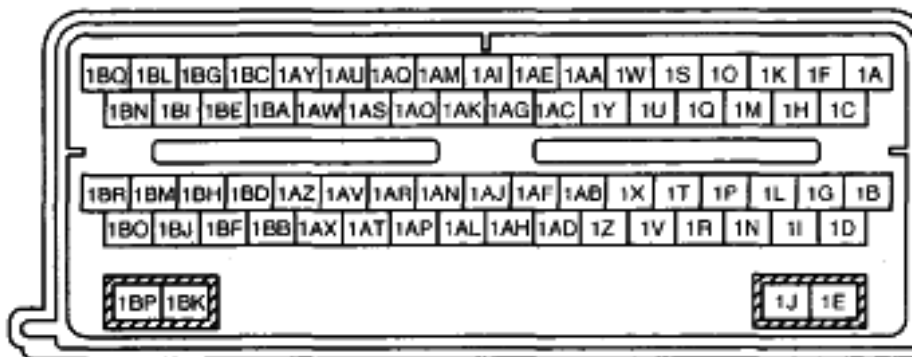
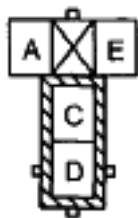
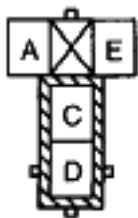



## 2007 Mazda CX-9 Grand Touring

2007 ENGINE PERFORMANCE On-Board Diagnostic (MZI-3.5) - CX-9

### DIAGNOSTIC PROCEDURE

#### DTC P0645 (MZI-3.5) DIAGNOSTIC PROCEDURE

STEP	INSPECTION	ACTION	
1	<b>VERIFY FREEZE FRAME DATA HAS BEEN RECORDED</b> <ul style="list-style-type: none"> <li>• Has FREEZE FRAME DATA been recorded?</li> </ul>	Yes	Go to the next step.
		No	Record FREEZE FRAME DATA on the repair order, then go to the next step.
2	<b>VERIFY RELATED REPAIR INFORMATION AVAILABILITY</b> <ul style="list-style-type: none"> <li>• Verify related Service Bulletins and/or on-line repair information availability.</li> <li>• Is any related Service Bulletins available?</li> </ul>	Yes	Perform repair or diagnosis according to the available Service Bulletins. <ul style="list-style-type: none"> <li>• If the vehicle is not repaired, go to the next step.</li> </ul>
		No	Go to the next step.
3	<b>INSPECT THAT THE ACCS PID IS OFF</b> <ul style="list-style-type: none"> <li>• Turn ignition key to ON (Engine running).</li> <li>• A/C switch and defroster switch off.</li> <li>• Access the ACCS PID using M-MDS.</li> <li>• Is the PID state off?</li> </ul>	Yes	Go to the next step.
		No	ACCS input to PCM is requesting A/C. Inspect A/C system operation, then go to Step 12. (see <b><u>DIAGNOSTIC TROUBLE CODE NUMBER INSPECTION</u></b> .) (see <b><u>TROUBLESHOOTING INDEX</u></b> .)
4	<b>INSPECT A/C RELAY CONNECTOR FOR POOR CONNECTOR</b> <ul style="list-style-type: none"> <li>• Turn the ignition switch off.</li> <li>• Disconnect the A/C relay connector.</li> <li>• Inspect for poor connection (such as damaged, pulled-out pins, corrosion, etc.).</li> <li>• Are there any malfunction?</li> </ul>	Yes	Repair or replace suspected part, then go to Step 12.
		No	Go to the next step.
5	<b>INSPECT A/C RELAY POWER SUPPLY CIRCUIT FOR OPEN CIRCUIT</b> <ul style="list-style-type: none"> <li>• Turn the ignition switch to the ON position (Engine off).</li> </ul>	Yes	Go to the next step.
		No	Repair or replace suspected part, then go to Step 12.

## 2007 Mazda CX-9 Grand Touring

2007 ENGINE PERFORMANCE On-Board Diagnostic (MZI-3.5) - CX-9

	<ul style="list-style-type: none"> <li>• Measure voltage between A/C relay terminal A (wiring harness-side) and body ground.</li> <li>• Is voltage <b>B+</b> ?</li> </ul>		
6	<b>INSPECT A/C RELAY CONTROL CIRCUIT FOR SHORT TO POWER SUPPLY</b> <ul style="list-style-type: none"> <li>• Turn the ignition switch to the ON position (Engine off).</li> <li>• Remove the A/C relay.</li> <li>• Measure voltage between A/C relay terminal E (wiring harness-side) and body ground.</li> <li>• Is voltage <b>B+</b> ?</li> </ul>	Yes	Repair or replace suspected part, then go to Step 12.
		No	Go to the next step.
7	<b>INSPECT A/C RELAY CONTROL CIRCUIT FOR SHORT TO GROUND</b> <ul style="list-style-type: none"> <li>• Install the A/C relay.</li> <li>• Turn the ignition switch off.</li> <li>• Inspect continuity between A/C relay terminal E (wiring harness-side) and body ground.</li> <li>• Is there continuity?</li> </ul>	Yes	Repair or replace suspected part, then go to Step 12.
		No	Go to the next step.
8	<b>INSPECT PCM CONNECTOR FOR POOR CONNECTION</b> <ul style="list-style-type: none"> <li>• Turn ignition switch to off.</li> <li>• Disconnect the PCM connector.</li> <li>• Inspect for poor connection (such as damaged, pulled-out pins, corrosion).</li> <li>• Is there any malfunction?</li> </ul>	Yes	Repair or replace suspected part, then go to Step 12.
		No	Go to the next step.
9	<b>INSPECT A/C RELAY CONTROL CIRCUIT FOR OPEN CIRCUIT</b> <ul style="list-style-type: none"> <li>• Turn the ignition switch off.</li> <li>• Inspect continuity between A/C relay terminal E (wiring harness-side) and PCM terminal 1N (wiring harness-side).</li> <li>• Is there continuity?</li> </ul>	Yes	Go to the next step.
		No	Repair or replace suspected part, then go to Step 12.

## 2007 Mazda CX-9 Grand Touring

2007 ENGINE PERFORMANCE On-Board Diagnostic (MZI-3.5) - CX-9

10	<b>INSPECT A/C RELAY</b> <ul style="list-style-type: none"> <li>• Inspect A/C relay.</li> </ul> <p style="text-align: center;">(see <b><u>RELAY INSPECTION</u></b> .)</p> <ul style="list-style-type: none"> <li>• Is A/C relay normal?</li> </ul>	Yes	Go to the next step.
		No	Replace the A/C relay. Start the engine. Turn on the A/C switch. Wait for <b>15 s</b> . Turn off the A/C switch, then go to Step 12.
11	<b>INSPECT FOR CORRECT PCM OPERATION</b> <ul style="list-style-type: none"> <li>• Disconnect all the PCM connectors.</li> <li>• Visually inspect for:                             <ul style="list-style-type: none"> <li>○ Pushed out pins</li> <li>○ Corrosion</li> </ul> </li> <li>• Connect all the PCM connectors and verify that they seat correctly.</li> <li>• Retrieve DTCs using the M-MDS.</li> <li>• Is the PENDING CODE for this DTC present?</li> </ul>	Yes	Go to the next step.
		No	The system is correctly. Go to the next step.
12	<b>VERIFY TROUBLESHOOTING OF DTC P0645 HAS BEEN COMPLETED</b> <ul style="list-style-type: none"> <li>• Verify that all disconnected connectors reconnected.</li> <li>• Clear the DTC from the PCM memory using the M-MDS.</li> <li>• Perform the "KOEO or KOER self-test" using the M-MDS.</li> </ul> <p style="text-align: center;">(See <b><u>KOEO/KOER SELF TEST [MZI-35]</u></b>)</p> <ul style="list-style-type: none"> <li>• Is the PENDING CODE for the DTC present?</li> </ul>	Yes	Replace the PCM, then go to the next step. (see <b><u>PCM REMOVAL/INSTALLATION [MZI-3.5]</u></b> .)
		No	Go to the next step.
13	<b>VERIFY AFTER REPAIR PROCEDURE</b> <ul style="list-style-type: none"> <li>• Perform the "AFTER REPAIR PROCEDURE".</li> </ul> <p style="text-align: center;">(See <b><u>AFTER REPAIR PROCEDURE [MZI-3.5]</u></b>.)</p>	Yes	Go to the applicable DTC inspection. (See <b><u>DTC TABLE [MZI-3.5]</u></b> .)
		No	Troubleshooting completed.

## 2007 Mazda CX-9 Grand Touring

2007 ENGINE PERFORMANCE On-Board Diagnostic (MZI-3.5) - CX-9

- Are any DTCs present?

### DTC P0685 [MZI-3.5]

#### DTC P0685 (MZI-3.5) DETECTION CONDITION AND POSSIBLE CAUSES

DTC P0685	ECM/PCM power relay control circuit/open
<b>DETECTION CONDITION</b>	<ul style="list-style-type: none"><li>• This DTC sets when the ignition switch position run circuit indicates the key is in off, ACC, or LOCK position, and the amount of time the PCM remains powered through the PCM power relay exceeds a predetermined amount of time.</li></ul>
<b>POSSIBLE CAUSE</b>	<ul style="list-style-type: none"><li>• Short to ground circuit between main relay No.1 terminal A and PCM terminal 11</li><li>• Main relay No.1 malfunction</li><li>• PCM malfunction</li></ul>

# 2007 Mazda CX-9 Grand Touring

2007 ENGINE PERFORMANCE On-Board Diagnostic (MZI-3.5) - CX-9

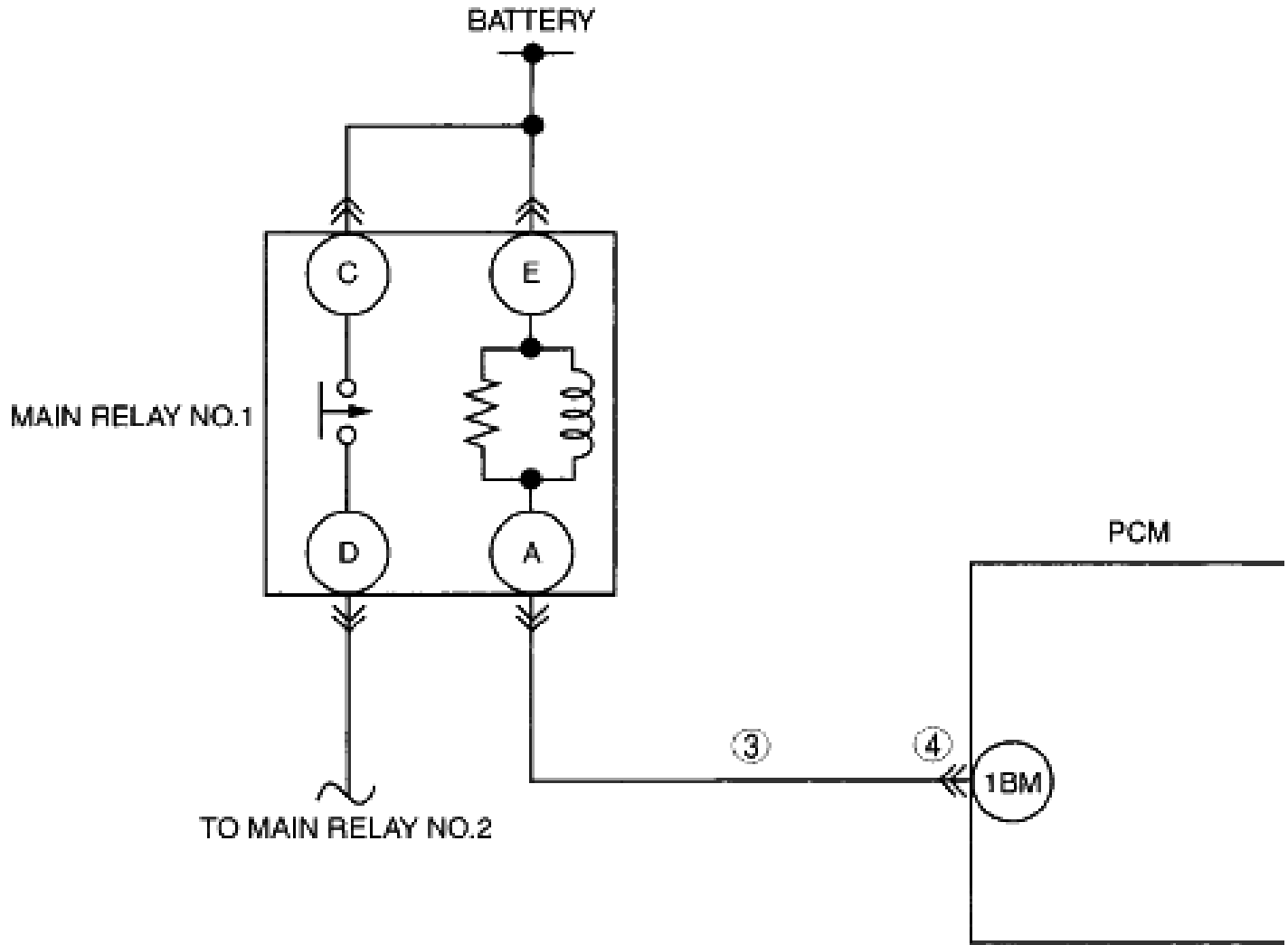

PCM  
WIRING HARNESS-SIDE CONNECTOR

MAIN RELAY NO.1

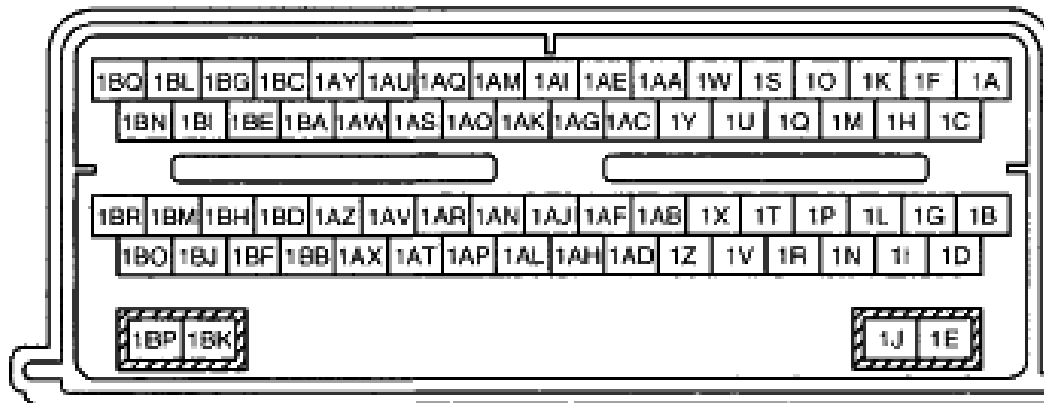
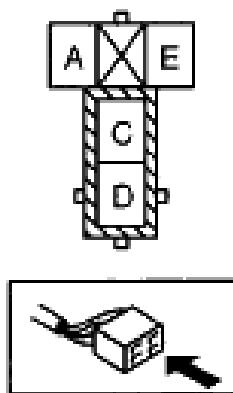

## 2007 Mazda CX-9 Grand Touring

2007 ENGINE PERFORMANCE On-Board Diagnostic (MZI-3.5) - CX-9

### DIAGNOSTIC PROCEDURE

#### DTC P0685 (MZI-3.5) DIAGNOSTIC PROCEDURE

STEP	INSPECTION	ACTION	
1	<b>VERIFY FREEZE FRAME DATA HAS BEEN RECORDED</b> <ul style="list-style-type: none"> <li>• Has FREEZE FRAME DATA been recorded?</li> </ul>	Yes	Go to the next step.
		No	Record FREEZE FRAME DATA on the repair order, then go to the next step.
2	<b>VERIFY RELATED REPAIR INFORMATION AVAILABILITY</b> <ul style="list-style-type: none"> <li>• Verify related Service Bulletins and/or on-line repair information availability.</li> <li>• Is any related Service Bulletins available?</li> </ul>	Yes	Perform repair or diagnosis according to the available Service Bulletins. <ul style="list-style-type: none"> <li>• If the vehicle is not repaired, go to the next step.</li> </ul>
		No	Go to the next step.
3	<b>INSPECT MAIN RELAY NO.1 CONTROL CIRCUIT FOR SHORT TO GROUND</b> <ul style="list-style-type: none"> <li>• Turn the ignition switch off.</li> <li>• Inspect for continuity between main relay No.1 terminal A (wiring harness-side) and body ground.</li> <li>• Is there continuity?</li> </ul>	Yes	Repair or replace suspected part, then go to Step 5.
		No	Go to the next step.
4	<b>INSPECT FOR CORRECT PCM OPERATION</b> <ul style="list-style-type: none"> <li>• Disconnect all the PCM connectors.</li> <li>• Visually inspect for:                             <ul style="list-style-type: none"> <li>○ Pushed out pins</li> <li>○ Corrosion</li> </ul> </li> <li>• Connect all the PCM connectors and verify that they seat correctly.</li> <li>• Retrieve DTCs using the M-MDS.</li> <li>• Is the PENDING CODE for this DTC present?</li> </ul>	Yes	Go to the next step.
		No	The system is correctly. Go to the next step.
5	<b>VERIFY TROUBLESHOOTING OF DTC P0685 HAS BEEN COMPLETED</b>	Yes	Replace the PCM, then go to the next step. (see <b>PCM REMOVAL/INSTALLATION [MZI-3.5]</b> .)

## 2007 Mazda CX-9 Grand Touring

2007 ENGINE PERFORMANCE On-Board Diagnostic (MZI-3.5) - CX-9

	<ul style="list-style-type: none"> <li>• Verify that all disconnected connectors reconnected.</li> <li>• Clear the DTC from the PCM memory using the M-MDS.</li> <li>• Perform the "KOEO or KOER self-test" using the M-MDS.</li> </ul> <p>(See <b><u>KOEO/KOER SELF TEST [MZI-3.5]</u></b>).</p> <ul style="list-style-type: none"> <li>• Is the PENDING CODE for the DTC present?</li> </ul>	No	Go to the next step.
6	<p><b>VERIFY AFTER REPAIR PROCEDURE</b></p> <ul style="list-style-type: none"> <li>• Perform the "AFTER REPAIR PROCEDURE".</li> </ul> <p>(See <b><u>AFTER REPAIR PROCEDURE [MZI-3.5]</u></b>).</p> <ul style="list-style-type: none"> <li>• Are any DTCs present?</li> </ul>	Yes	Go to the applicable DTC inspection. (See <b><u>DTC TABLE [MZI-3.5]</u></b> .)
		No	Troubleshooting completed.

### DTC P0689 [MZI-3.5]

#### DTC P0689 (MZI-3.5) DETECTION CONDITION AND POSSIBLE CAUSES

<b>DTC P0689</b>	<b>ECM/PCM power relay sense circuit low</b>
<b>DETECTION CONDITION</b>	<ul style="list-style-type: none"> <li>• This DTC sets when the passive anti theft system (PATS) system indicates the key ON or START position and the ignition switch position run circuit indicates OFF, ACC, or LOCK position.</li> </ul>
<b>POSSIBLE CAUSE</b>	<ul style="list-style-type: none"> <li>• Ignition circuit fuse (MAIN, IG KEY 1, IG KEY 2)</li> <li>• Open circuit between battery positive terminal and PCM terminal 1 BD</li> <li>• Short to ground circuit between battery positive terminal and PCM terminal 1 BD</li> <li>• Ignition switch malfunction</li> <li>• PATS system malfunction</li> </ul>

# 2007 Mazda CX-9 Grand Touring

2007 ENGINE PERFORMANCE On-Board Diagnostic (MZI-3.5) - CX-9

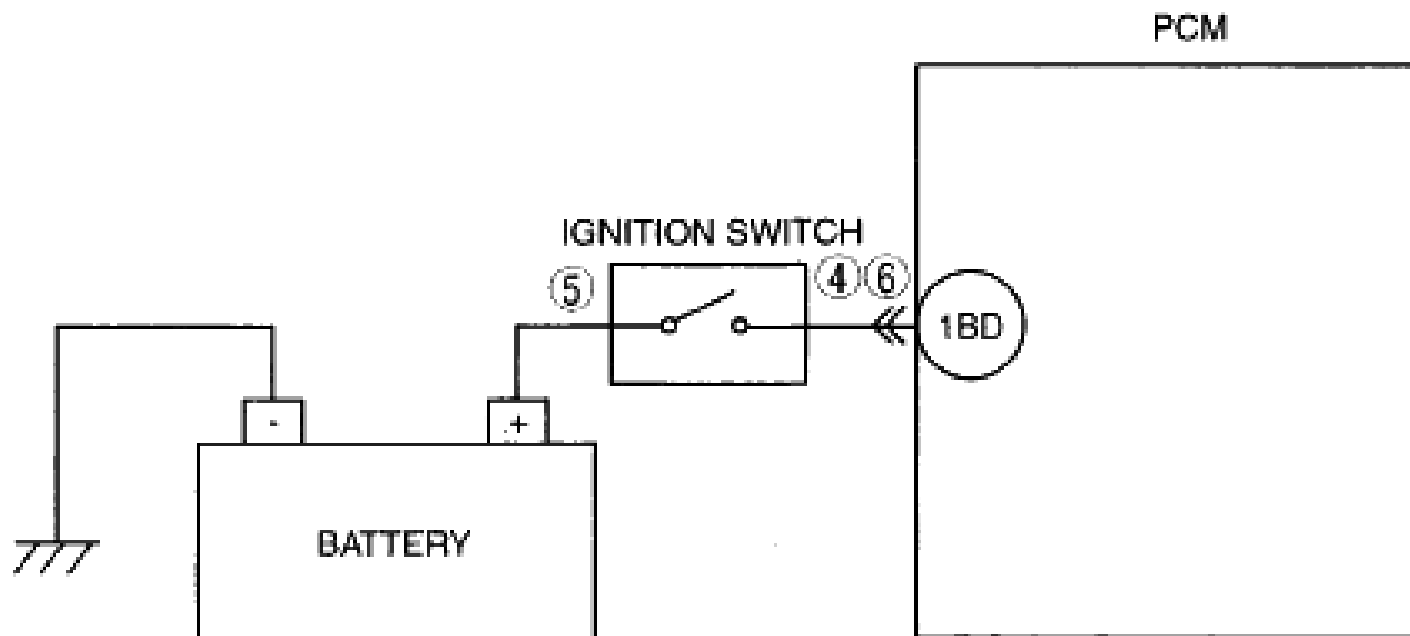

PCM  
WIRING HARNESS-SIDE CONNECTOR

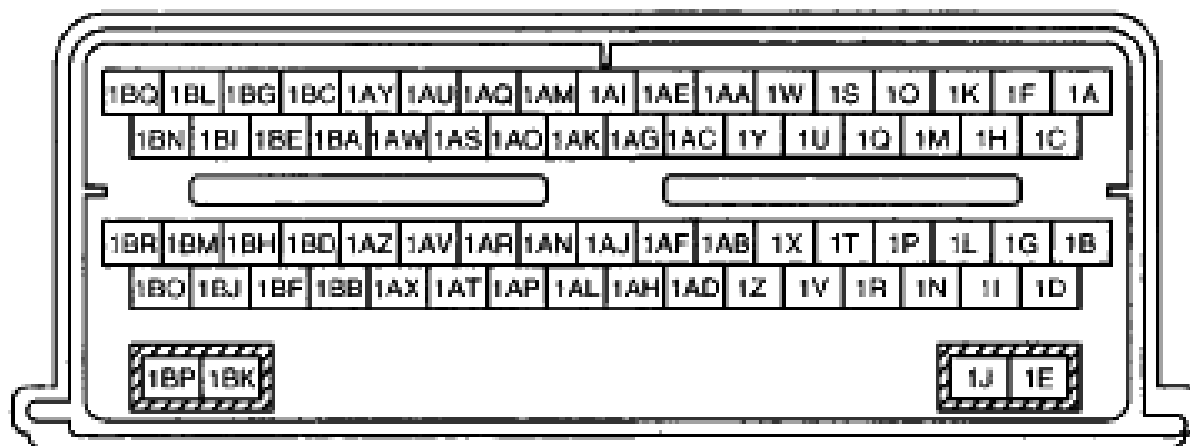



## 2007 Mazda CX-9 Grand Touring

2007 ENGINE PERFORMANCE On-Board Diagnostic (MZI-3.5) - CX-9

### DTC P0689 (MZI-3.5) DIAGNOSTIC PROCEDURE

STEP	INSPECTION	ACTION	
1	<b>VERIFY FREEZE FRAME DATA HAS BEEN RECORDED</b> <ul style="list-style-type: none"> <li>• Has FREEZE FRAME DATA been recorded?</li> </ul>	Yes	Go to the next step.
		No	Record FREEZE FRAME DATA on the repair order, then go to the next step.
2	<b>VERIFY RELATED REPAIR INFORMATION AVAILABILITY</b> <ul style="list-style-type: none"> <li>• Verify related Service Bulletins and/or on-line repair information availability.</li> <li>• Is any related Service Bulletins available?</li> </ul>	Yes	Perform repair or diagnosis according to the available Service Bulletins. <ul style="list-style-type: none"> <li>• If the vehicle is not repaired, go to the next step.</li> </ul>
		No	Go to the next step.
3	<b>INSPECT ALL OTHER PATS DTCs</b> <ul style="list-style-type: none"> <li>• Repair all other PATS DTCs before P0689.</li> </ul> (see <b><u>IMMOBILIZER SYSTEM COMPONENT REPLACEMENT/KEY ADDITION AND CLEARING [ADVANCED KEYLESS SYSTEM]</u></b> .)  (see <b><u>IMMOBILIZER SYSTEM COMPONENT REPLACEMENT/KEY ADDITION AND CLEARING [KEYLESS ENTRY SYSTEM]</u></b> .)  <ul style="list-style-type: none"> <li>• Have all other PATS DTCs been diagnosed?</li> </ul>	Yes	Go to the next step.
		No	(see <b><u>IMMOBILIZER SYSTEM COMPONENT REPLACEMENT/KEY ADDITION AND CLEARING [ADVANCED KEYLESS SYSTEM]</u></b> .) (see <b><u>IMMOBILIZER SYSTEM COMPONENT REPLACEMENT/KEY ADDITION AND CLEARING [KEYLESS ENTRY SYSTEM]</u></b> .)
4	<b>INSPECT PCM CONNECTOR FOR POOR CONNECTION</b> <ul style="list-style-type: none"> <li>• Turn the ignition switch off.</li> <li>• Disconnect the PCM connector.</li> <li>• Inspect for poor connection (such as damaged, pulled-out pins, corrosion).</li> <li>• Is there any malfunction?</li> </ul>	Yes	Repair or replace suspected part, then go to Step 7.
		No	Go to the next step.
5	<b>INSPECT BATTERY POSITIVE</b>	Yes	Go to the next step.

## 2007 Mazda CX-9 Grand Touring

2007 ENGINE PERFORMANCE On-Board Diagnostic (MZI-3.5) - CX-9

	<p><b>CIRCUIT FOR OPEN CIRCUIT</b></p> <ul style="list-style-type: none"> <li>• Turn the ignition switch to the ON position (Engine off).</li> <li>• Measure the voltage between PCM terminal 1 BD (wiring harness-side) and body ground.</li> <li>• Is the voltage <b>B+</b> ?</li> </ul>	No	Repair or replace suspected part, then go to Step 7.
6	<p><b>INSPECT FOR CORRECT PCM OPERATION</b></p> <ul style="list-style-type: none"> <li>• Disconnect all the PCM connectors.</li> <li>• Visually inspect for:                             <ul style="list-style-type: none"> <li>○ Pushed out pins</li> <li>○ Corrosion</li> </ul> </li> <li>• Connect all the PCM connectors and verify that they seat correctly.</li> <li>• Retrieve DTCs using the M-MDS.</li> <li>• Is the PENDING CODE for this DTC present?</li> </ul>	Yes	Go to the next step.
		No	The system is correctly. Go to the next step.
7	<p><b>VERIFY TROUBLESHOOTING OF DTC P0689 HAS BEEN COMPLETED</b></p> <ul style="list-style-type: none"> <li>• Verify that all disconnected connectors reconnected.</li> <li>• Clear the DTC from the PCM memory using the M-MDS.</li> <li>• Perform the "KOEO or KOER self-test" using the M-MDS.</li> </ul> <p>(See <b><u>KOEO/KOER SELF TEST [MZI-3.5].</u></b>)</p> <ul style="list-style-type: none"> <li>• Is the PENDING CODE for the DTC present?</li> </ul>	Yes	Replace the PCM, then go to the next step. (see <b><u>PCM REMOVAL/INSTALLATION [MZI-3.5]</u></b> .)
		No	Go to the next step.
8	<p><b>VERIFY AFTER REPAIR PROCEDURE</b></p> <ul style="list-style-type: none"> <li>• Perform the "AFTER REPAIR PROCEDURE". (See <b><u>AFTER REPAIR PROCEDURE [MZI-3.5].</u></b>)</li> <li>• Are any DTCs present?</li> </ul>	Yes	Go to the applicable DTC inspection. (See <b><u>DTC TABLE [MZI-3.5].</u></b> )
		No	Troubleshooting completed.

## 2007 Mazda CX-9 Grand Touring

2007 ENGINE PERFORMANCE On-Board Diagnostic (MZI-3.5) - CX-9

### DTC P0690 [MZI-3.5]

#### DTC P0690 (MZI-3.5) DETECTION CONDITION AND POSSIBLE CAUSES

DTC P0690	ECM/PCM power relay sense circuit high
<b>DETECTION CONDITION</b>	<ul style="list-style-type: none"><li>• This DTC sets when the passive anti theft system (PATS) system indicates the key is in the OFF, ACC, or LOCK position and the ignition switch position run circuit indicates ON or START position.</li></ul>
<b>POSSIBLE CAUSE</b>	<ul style="list-style-type: none"><li>• Short to power supply between battery positive terminal and PCM terminal 1 BD</li><li>• PATS system malfunction</li><li>• Ignition switch malfunction</li></ul>

# 2007 Mazda CX-9 Grand Touring

2007 ENGINE PERFORMANCE On-Board Diagnostic (MZI-3.5) - CX-9

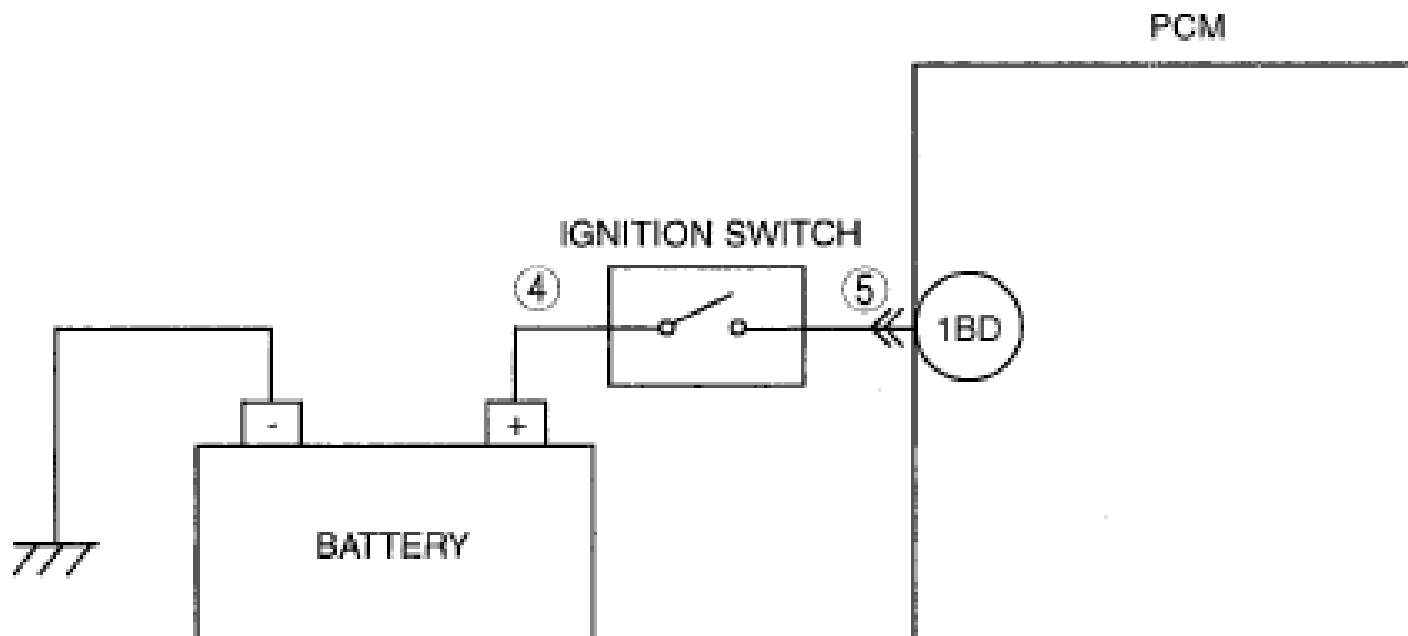

PCM  
WIRING HARNESS-SIDE CONNECTOR

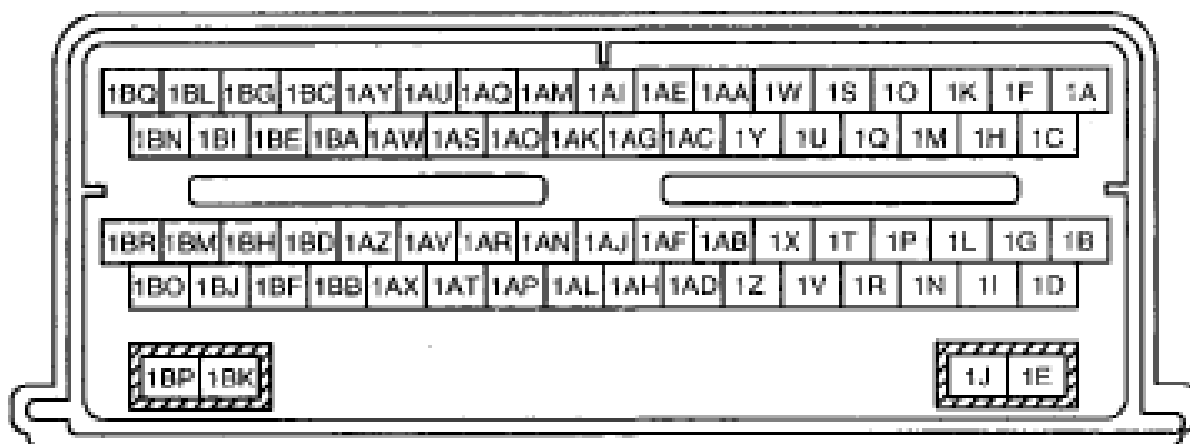

## 2007 Mazda CX-9 Grand Touring

2007 ENGINE PERFORMANCE On-Board Diagnostic (MZI-3.5) - CX-9

### DTC P0690 (MZI-3.5) DIAGNOSTIC PROCEDURE

STEP	INSPECTION	ACTION
1	<b>VERIFY FREEZE FRAME DATA HAS BEEN RECORDED</b> <ul style="list-style-type: none"> <li>• Has FREEZE FRAME DATA been recorded?</li> </ul>	Yes Go to the next step.
	No Record FREEZE FRAME DATA on the repair order, then go to the next step.	No Record FREEZE FRAME DATA on the repair order, then go to the next step.
2	<b>VERIFY RELATED REPAIR INFORMATION AVAILABILITY</b> <ul style="list-style-type: none"> <li>• Verify related Service Bulletins and/or on-line repair information availability.</li> <li>• Is any related Service Bulletins available?</li> </ul>	Yes Perform repair or diagnosis according to the available Service Bulletins. <ul style="list-style-type: none"> <li>• If the vehicle is not repaired, go to the next step.</li> </ul>
	No Go to the next step.	No Go to the next step.
3	<b>INSPECT ALL OTHER PATS DTCs</b> <ul style="list-style-type: none"> <li>• Repair all other PATS DTCs before P0690.</li> </ul> <p>(see <b><u>IMMOBILIZER SYSTEM COMPONENT REPLACEMENT/KEY ADDITION AND CLEARING [ADVANCED KEYLESS SYSTEM]</u></b> .)</p> <p>(see <b><u>IMMOBILIZER SYSTEM COMPONENT REPLACEMENT/KEY ADDITION AND CLEARING [KEYLESS ENTRY SYSTEM]</u></b> .)</p> <ul style="list-style-type: none"> <li>• Have all other PATS DTCs been diagnosed?</li> </ul>	Yes Go to the next step.
	No (see <b><u>IMMOBILIZER SYSTEM COMPONENT REPLACEMENT/KEY ADDITION AND CLEARING [ADVANCED KEYLESS SYSTEM]</u></b> .) (see <b><u>IMMOBILIZER SYSTEM COMPONENT REPLACEMENT/KEY ADDITION AND CLEARING [KEYLESS ENTRY SYSTEM]</u></b> .)	No (see <b><u>IMMOBILIZER SYSTEM COMPONENT REPLACEMENT/KEY ADDITION AND CLEARING [ADVANCED KEYLESS SYSTEM]</u></b> .) (see <b><u>IMMOBILIZER SYSTEM COMPONENT REPLACEMENT/KEY ADDITION AND CLEARING [KEYLESS ENTRY SYSTEM]</u></b> .)
4	<b>INSPECT IGNITION SWITCH POSITION RUN CIRCUIT SHORT TO POWER SUPPLY</b> <ul style="list-style-type: none"> <li>• Turn the ignition switch off.</li> <li>• Measure the voltage between PCM terminal 1BD (wiring harness-side) and body ground.</li> <li>• Is the voltage B+ ?</li> </ul>	Yes Repair or replace suspected part, then go to Step 6.
	No Go to the next step.	No Go to the next step.
5	<b>INSPECT FOR CORRECT PCM</b>	Yes Go to the next step.

## 2007 Mazda CX-9 Grand Touring

2007 ENGINE PERFORMANCE On-Board Diagnostic (MZI-3.5) - CX-9

	<p><b>OPERATION</b></p> <ul style="list-style-type: none"> <li>• Disconnect all the PCM connectors.</li> <li>• Visually inspect for: <ul style="list-style-type: none"> <li>○ Pushed out pins</li> <li>○ Corrosion</li> </ul> </li> <li>• Connect all the PCM connectors and verify that they seat correctly.</li> <li>• Retrieve DTCs using the M-MDS.</li> <li>• Is the PENDING CODE for this DTC present?</li> </ul>	No	The system is correctly. Go to the next step.
6	<p><b>VERIFY TROUBLESHOOTING OF DTC P0690 HAS BEEN COMPLETED</b></p> <ul style="list-style-type: none"> <li>• Verify that all disconnected connectors reconnected.</li> <li>• Clear the DTC from the PCM memory using the M-MDS.</li> <li>• Clear the DTC from the PCM memory using the M-MDS.</li> <li>• Perform the "KOEO or KOER self-test" using the M-MDS.</li> </ul> <p>(See <b><u>KOEO/KOER SELF TEST [MZI-3.5]</u></b>.)</p> <ul style="list-style-type: none"> <li>• Is the PENDING CODE for the DTC present?</li> </ul>	Yes	Replace the PCM, then go to the next step. (see <b><u>PCM REMOVAL/INSTALLATION [MZI-3.5]</u></b> .)
		No	Go to the next step.
7	<p><b>VERIFY AFTER REPAIR PROCEDURE</b></p> <ul style="list-style-type: none"> <li>• Perform the "AFTER REPAIR PROCEDURE".</li> </ul> <p>(See <b><u>AFTER REPAIR PROCEDURE [MZI-3.5]</u></b>.)</p> <ul style="list-style-type: none"> <li>• Are any DTCs present?</li> </ul>	Yes	Go to the applicable DTC inspection. (See <b><u>DTC TABLE [MZI-3.5]</u></b> .)
		No	Troubleshooting completed.

### DTC P1000 [MZI-3.5]

#### DTC P1000 (MZI-3.5) DETECTION CONDITION AND POSSIBLE CAUSES

<b>DTC P1000</b>	<b>OBD-II systems readiness test not complete</b>
------------------	---

## 2007 Mazda CX-9 Grand Touring

2007 ENGINE PERFORMANCE On-Board Diagnostic (MZI-3.5) - CX-9

<b>DETECTION CONDITION</b>	<ul style="list-style-type: none"> <li>• P1000 indicates that the OBD-II monitor testing is not complete.</li> </ul>
<b>POSSIBLE CAUSE</b>	<ul style="list-style-type: none"> <li>• The vehicle is new from the factory and has not yet completed an OBD-II Drive Cycle.</li> <li>• The battery or the PCM has been disconnected.</li> <li>• OBD-II monitor malfunction had occurred before completion of an OBD-II Drive Cycle.</li> <li>• The PCM DTCs have been cleared with an M-MDS tester as part of a service process.</li> </ul>

### DIAGNOSTIC PROCEDURE

#### DTC P1000 (MZI-3.5) DIAGNOSTIC PROCEDURE

STEP	INSPECTION		ACTION
1	<b>VERIFY FREEZE FRAME DATA HAS BEEN RECORDED</b> <ul style="list-style-type: none"> <li>• Has FREEZE FRAME DATA been recorded?</li> </ul>	Yes	Go to the next step.
		No	Record FREEZE FRAME DATA on the repair order, then go to the next step.
2	<b>VERIFY RELATED REPAIR INFORMATION AVAILABILITY</b> <ul style="list-style-type: none"> <li>• Verify related Service Bulletins and/or on-line repair information availability.</li> <li>• Is any related Service Bulletins available?</li> </ul>	Yes	Perform repair or diagnosis according to the available Service Bulletins. <ul style="list-style-type: none"> <li>• If the vehicle is not repaired, go to the next step.</li> </ul>
		No	Go to the next step.
3	<b>DTC P1000: INSPECT FOR OTHER DTCS</b> <ul style="list-style-type: none"> <li>• This test should be used only if DTC P1000 was received in Continuous Memory. Ignore any DTC P1000s in KOEO or KOER.</li> </ul> <p><b>NOTE:</b></p> <ul style="list-style-type: none"> <li>• <b>DTC P1000 indicates that all of the OBD-II monitors have not yet been successfully tested to clear DTC P1000.</b></li> <li>• Were any other DTCs received with P1000?</li> </ul>	Yes	Repair other DTCs. Go to the applicable DTC Troubleshooting.
		No	Go to the next step.
4	<b>REQUEST TO CLEAR DTC P1000</b>	Yes	Perform the Drive Mode.

## 2007 Mazda CX-9 Grand Touring

2007 ENGINE PERFORMANCE On-Board Diagnostic (MZI-3.5) - CX-9

	<ul style="list-style-type: none"> <li>Has the customer requested DTC P1000 be cleared from the PCM memory?</li> </ul>		(See <b>OBD-II DRIVE MODE [MZI-3.5].</b> )
		No	Inform customer that if the law in the state requires additional driving in order to clear DTC P1000 from the PCM memory, it must be performed before an inspection maintenance test.
5	<b>VERIFY AFTER REPAIR PROCEDURE</b> <ul style="list-style-type: none"> <li>Perform the "AFTER REPAIR PROCEDURE".</li> </ul> <p>(See <b>AFTER REPAIR PROCEDURE [MZI-3.5].</b>)</p> <ul style="list-style-type: none"> <li>Are any DTC present?</li> </ul>	Yes	Go to the applicable DTC inspection. (See <b>DTC TABLE [MZI-3.5].</b> )
		No	Troubleshooting completed.

### DTC P1001 [MZI-3.5]

#### DTC P1001 (MZI-3.5) DETECTION CONDITION AND POSSIBLE CAUSES

DTC P1001	KOER not able to complete, KOER aborted
<b>DETECTION CONDITION</b>	<ul style="list-style-type: none"> <li>P1001 indicates any of the following</li> <li>Unable to access Continuous Memory DTCs.</li> <li>Unable to activate KOEO or KOER Self-Test.</li> <li>M-MDS tester communication problem.</li> <li>DTC displayed by M-MDS tester not listed.</li> <li>KOER Self-Test cannot be completed.</li> </ul>
<b>POSSIBLE CAUSE</b>	<ul style="list-style-type: none"> <li>Damaged DLC-2.</li> <li>Incorrect Self-Test procedure.</li> <li>VREF is not in specification.</li> <li>Idle RPM out of specification.</li> <li>Open in DLC-2 wiring harness circuit.</li> <li>Short in DLC-2 circuit or associated modules.</li> <li>Damaged PCM power relay circuit</li> </ul>

#### DIAGNOSTIC PROCEDURE

##### DTC P1001 (MZI-3.5) DIAGNOSTIC PROCEDURE

STEP	INSPECTION		ACTION
1	<b>VERIFY FREEZE FRAME DATA HAS BEEN RECORDED</b>	Yes	Go to the next step.



## 2007 Mazda CX-9 Grand Touring

2007 ENGINE PERFORMANCE On-Board Diagnostic (MZI-3.5) - CX-9

	<ul style="list-style-type: none"> <li>• Has FREEZE FRAME DATA been recorded?</li> </ul>	No	Record FREEZE FRAME DATA on the repair order, then go to the next step.
2	<b>VERIFY RELATED REPAIR INFORMATION AVAILABILITY</b> <ul style="list-style-type: none"> <li>• Verify related Service Bulletins and/or on-line repair information availability.</li> <li>• Is any related Service Bulletins available?</li> </ul>	Yes	Perform repair or diagnosis according to the available Service Bulletins. <ul style="list-style-type: none"> <li>• If the vehicle is not repaired, go to the next step.</li> </ul>
		No	Go to the next step.
3	<b>VERIFY RELATED PENDING CODE OR STORED DTCs</b> <ul style="list-style-type: none"> <li>• Turn the ignition switch off then to the ON position (Engine off).</li> <li>• Verify related pending code or stored DTCs.</li> <li>• Are other DTCs present?</li> </ul>	Yes	Go to the appropriate DTC troubleshooting. (See <b>DTC TABLE [MZI-3.5]</b> .)
		No	Go to the next step.
4	<b>INSPECT FOR CORRECT PCM OPERATION</b> <ul style="list-style-type: none"> <li>• Disconnect all the PCM connectors.</li> <li>• Visually inspect for:               <ul style="list-style-type: none"> <li>○ Pushed out pins</li> <li>○ Corrosion</li> </ul> </li> <li>• Connect all the PCM connectors and verify that they seat correctly.</li> <li>• Retrieve DTCs using the M-MDS.</li> <li>• Is the PENDING CODE for this DTC present?</li> </ul>	Yes	Replace the PCM, then go to the next step. (see <b>PCM REMOVAL/INSTALLATION [MZI-3.5]</b> .)
		No	Go to the next step.
5	<b>VERIFY TROUBLESHOOTING OF DTC P1001 HAS BEEN COMPLETED</b> <ul style="list-style-type: none"> <li>• Verify that all disconnected connectors are reconnected.</li> <li>• Turn the ignition switch to the ON position (Engine off).</li> <li>• Clear the DTC from the PCM memory using the M-MDS.</li> <li>• Start the engine and run it at idle.</li> </ul>	Yes	Replace the PCM, then go to the next step. (see <b>PCM REMOVAL/INSTALLATION [MZI-3.5]</b> .)

## 2007 Mazda CX-9 Grand Touring

2007 ENGINE PERFORMANCE On-Board Diagnostic (MZI-3.5) - CX-9

	<ul style="list-style-type: none"> <li>Retrieve DTCs using the M-MDS.</li> <li>Is the PENDING CODE for this DTC present?</li> </ul>	No	Go to the next step.
6	<p><b>VERIFY AFTER REPAIR PROCEDURE</b></p> <ul style="list-style-type: none"> <li>Perform the "After Repair Procedure".</li> </ul> <p>(See <b><u>AFTER REPAIR PROCEDURE [MZI-3.5]</u></b>.)</p> <ul style="list-style-type: none"> <li>Are any DTC present?</li> </ul>	Yes	Go to the applicable DTC inspection. (See <b><u>DTC TABLE [MZI-3.5]</u></b> .)
		No	Troubleshooting completed.

### DTC P1101 [MZI-3.5]

#### DTC P1101 (MZI-3.5) DETECTION CONDITION AND POSSIBLE CAUSES

DTC P1101	MAP sensor out of self-test range
<b>DETECTION CONDITION</b>	<ul style="list-style-type: none"> <li>The MAP sensor circuit is monitored by the PCM for an out of range air flow (or voltage) input. If, during KOEO, the air flow voltage signal is more than 0.27 V w the ignition switch in the ON position (Engine off). Likewise, the test fails if the airflow voltage signal is not within 0.46 to 2.44 V with the ignition switch in the ( position (Engine running) (KOER).</li> </ul>
<b>POSSIBLE CAUSE</b>	<ul style="list-style-type: none"> <li>Low battery charge</li> <li>Open circuit wiring harness between MAP sensor terminal B (wiring harness-side body ground</li> <li>Open circuit wiring harness between MAP sensor terminal C (wiring harness-side PCM terminal 1AJ (wiring harness-side)</li> <li>Connector or terminal malfunction</li> <li>MAP sensor malfunction</li> </ul>

## 2007 Mazda CX-9 Grand Touring

2007 ENGINE PERFORMANCE On-Board Diagnostic (MZI-3.5) - CX-9

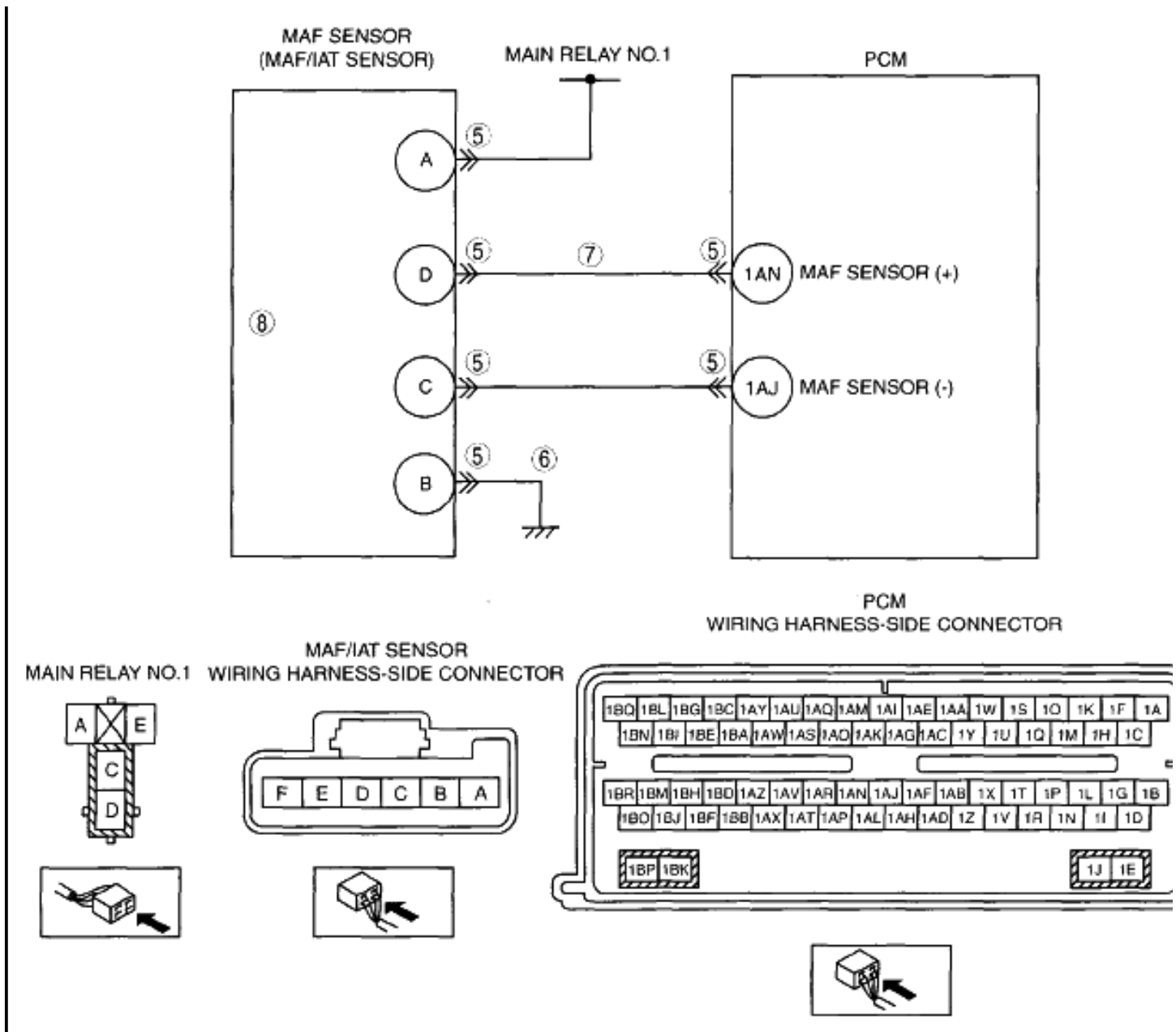

### DIAGNOSTIC PROCEDURE

#### DTC P1101 (MZI-3.5) DIAGNOSTIC PROCEDURE

STEP	INSPECTION		ACTION
1	<b>VERIFY FREEZE FRAME DATA HAS BEEN RECORDED</b>	Yes	Go to next step.
		No	Record FREEZE FRAME DATA on the repair order, then go to next step.
2	<b>VERIFY RELATED REPAIR</b>	Yes	Perform repair or diagnosis according to

## 2007 Mazda CX-9 Grand Touring

2007 ENGINE PERFORMANCE On-Board Diagnostic (MZI-3.5) - CX-9

	<p><b>INFORMATION AVAILABILITY</b></p> <ul style="list-style-type: none"> <li>• Verify related Service Bulletins availability.</li> <li>• Is any related Service Bulletins available?</li> </ul>		<p>available Service Bulletins.</p> <ul style="list-style-type: none"> <li>• If vehicle is not repaired, go to next step.</li> </ul>
		No	Go to the next step.
3	<p><b>VERIFY RELATED PENDING CODE OR STORED DTC</b></p> <ul style="list-style-type: none"> <li>• Verify the related PENDING CODE or stored DTCs.</li> <li>• Are other DTCs present?</li> </ul>	Yes	Go to appropriate DTC inspection. (See <b><u>DTC TABLE [MZI-3.5]</u></b> .)
		No	Go to the next step.
4	<p><b>INSPECT MAP SIGNAL SENT TO PCM</b></p> <ul style="list-style-type: none"> <li>• Turn the ignition switch to the ON position (Engine running).</li> <li>• Access MAP PID using the M-MDS</li> <li>• Is the voltage between 0.46-2.44 V</li> </ul>	Yes	Perform the "INTERMITTENT CONCERN TROUBLESHOOTING". Then go to Step 10.
		No	Go to the next step.
5	<p><b>INSPECT MAP SENSOR AND PCM CONNECTOR FOR POOR CONNECTION</b></p> <ul style="list-style-type: none"> <li>• Turn the ignition switch off.</li> <li>• Disconnect the MAF/IAT sensor and PCM connector.</li> <li>• Inspect for poor connection (such as damaged/pulled-out pins, corrosion).</li> <li>• Are there any malfunction?</li> </ul>	Yes	Repair or replace suspected part, then go to Step 10.
		No	Go to the next step.
6	<p><b>INSPECT MAF SENSOR GROUND CIRCUIT FOR OPEN CIRCUIT</b></p> <ul style="list-style-type: none"> <li>• Turn the ignition switch off.</li> <li>• Inspect continuity between MAF sensor terminal B (wiring harness-side) and body ground.</li> <li>• Is there continuity?</li> </ul>	Yes	Go to the next step.
		No	Repair or replace suspected part, then go to Step 10.
7	<p><b>INSPECT MAF SENSOR SIGNAL CIRCUIT FOR OPEN CIRCUIT</b></p> <ul style="list-style-type: none"> <li>• Turn the ignition switch off.</li> </ul>	Yes	Go to the next step.

## 2007 Mazda CX-9 Grand Touring

2007 ENGINE PERFORMANCE On-Board Diagnostic (MZI-3.5) - CX-9

	<ul style="list-style-type: none"> <li>Inspect continuity between MAF sensor terminal C (wiring harness-side) and PCM terminal 1AJ (wiring harness-side).</li> <li>Is there continuity?</li> </ul>	No	Repair or replace suspected part, then go to Step 10.
8	<p><b>INSPECT MAF SENSOR</b></p> <ul style="list-style-type: none"> <li>Inspect the MAF sensor.</li> </ul> <p>(see <b>MASS AIR FLOW (MAF) SENSOR INSPECTION [MZI-3.5]</b>.)</p> <ul style="list-style-type: none"> <li>Is there any malfunction?</li> </ul>	Yes	Replace the MAF/IAT sensor, then go to Step 10.
		No	Go to the next step.
9	<p><b>INSPECT FOR CORRECT PCM OPERATION</b></p> <ul style="list-style-type: none"> <li>Disconnect all the PCM connectors.</li> <li>Visually inspect for:                             <ul style="list-style-type: none"> <li>Pushed out pins</li> <li>Corrosion</li> </ul> </li> <li>Connect all the PCM connectors and verify that they seat correctly.</li> <li>Retrieve DTCs using the M-MDS.</li> <li>Is the PENDING CODE for this DTC present?</li> </ul>	Yes	Go to the next step.
		No	The system is correctly. Go to the next step.
10	<p><b>VERIFY TROUBLESHOOTING OF DTC P1101 HAS BEEN COMPLETED</b></p> <ul style="list-style-type: none"> <li>Verify that all disconnected connectors reconnected.</li> <li>Clear DTC from memory using M-MDS.</li> <li>Start engine.</li> <li>Perform "KOEO/KOER self-test"</li> </ul> <p>(See <b>KOEO/KOER SELF TEST [MZI-3.5]</b>.)</p> <ul style="list-style-type: none"> <li>Is same DTC present?</li> </ul>	Yes	Replace PCM, then go to the next step. (see <b>PCM REMOVAL/INSTALLATION [MZI-3.5]</b> .)
		No	Go to the next step.
11	<p><b>VERIFY AFTER REPAIR</b></p>	Yes	Go to the applicable DTC inspection.

## 2007 Mazda CX-9 Grand Touring

2007 ENGINE PERFORMANCE On-Board Diagnostic (MZI-3.5) - CX-9

<p><b>PROCEDURE</b></p> <ul style="list-style-type: none"> <li>Perform "AFTER REPAIR PROCEDURE".</li> </ul> <p>(See <b><u>AFTER REPAIR PROCEDURE [MZI-3.5].</u></b>)</p> <ul style="list-style-type: none"> <li>Are any DTC present?</li> </ul>		(See <b><u>DTC TABLE [MZI-3.5].</u></b> )
	No	Troubleshooting completed.

### DTC P1127 [MZI-3.5]

#### DTC P1127 (MZI-3.5) DETECTION CONDITION AND POSSIBLE CAUSES

<b>DTC P1127</b>	<b>Exhaust temperature out of range, HO2S tests not completed</b>
<b>DETECTION CONDITION</b>	<ul style="list-style-type: none"> <li>The HO2S monitor uses an exhaust temperature model to determine when the HO2S heaters are cycled ON. The test fails when the inferred exhaust temperature is below a minimum calibrated value.</li> </ul>
<b>POSSIBLE CAUSE</b>	<ul style="list-style-type: none"> <li>Engine not operating long enough prior to carrying out the KOER self-test</li> <li>Exhaust system too cool</li> </ul>

#### DIAGNOSTIC PROCEDURE

#### DTC P1127 (MZI-3.5) DIAGNOSTIC PROCEDURE

STEP	INSPECTION		ACTION
1	<b>VERIFY FREEZE FRAME DATA HAS BEEN RECORDED</b> <ul style="list-style-type: none"> <li>Has FREEZE FRAME DATA been recorded?</li> </ul>	Yes	Go to the next step.
		No	Record FREEZE FRAME DATA on the repair order, then go to next step.
2	<b>VERIFY RELATED REPAIR INFORMATION AVAILABILITY</b> <ul style="list-style-type: none"> <li>Verify related Service Bulletins availability.</li> <li>Is any related Service Bulletins available?</li> </ul>	Yes	Perform repair or diagnosis according to available Service Bulletins. <ul style="list-style-type: none"> <li>If vehicle is not repaired, go to next step.</li> </ul>
		No	Go to the next step.
3	<b>EXHAUST TEMPERATURE OUT OF RANGE Note</b> <p><b>NOTE:</b></p> <ul style="list-style-type: none"> <li>Address all other DTCs before proceeding.</li> </ul>	Yes	Perform the KOER self-test, then go to the next step. (See <b><u>KOEO/KOER SELF TEST [MZI-3.5].</u></b> )
		No	Run the engine until the PID indicates ON.

## 2007 Mazda CX-9 Grand Touring

2007 ENGINE PERFORMANCE On-Board Diagnostic (MZI-3.5) - CX-9

	<ul style="list-style-type: none"> <li>• Turn the ignition switch to the ON position (Engine running)</li> <li>• Verify that the engine is at normal operating temperature.</li> <li>• Access the PCM and monitor the HO2S heater PID.</li> <li>• Is the PID state ON?</li> </ul>		Perform the KOER self-test, then go to the next step. (See <b><u>KOEO/KOER SELF TEST [MZI-3.5].</u></b> )
4	<b>VERIFY TROUBLESHOOTING OF DTC P1127 HAS BEEN COMPLETED</b> <ul style="list-style-type: none"> <li>• Verify that all disconnected connectors reconnected.</li> <li>• Clear DTC from memory using M-MDS.</li> <li>• Start engine.</li> <li>• Perform "KOEO/KOER self-test"</li> </ul> <p>(See <b><u>KOEO/KOER SELF TEST [MZI-3.5].</u></b>)</p> <ul style="list-style-type: none"> <li>• Is same DTC present?</li> </ul>	Yes	Replace PCM, then go to the next step. (see <b><u>PCM REMOVAL/INSTALLATION [MZI-3.5] .</u></b> )
		No	Go to the next step.
5	<b>VERIFY AFTER REPAIR PROCEDURE</b> <ul style="list-style-type: none"> <li>• Perform "AFTER REPAIR PROCEDURE".</li> </ul> <p>(See <b><u>AFTER REPAIR PROCEDURE [MZI-3.5].</u></b>)</p> <ul style="list-style-type: none"> <li>• Are any DTC present?</li> </ul>	Yes	Go to the applicable DTC inspection. (See <b><u>DTC TABLE [MZI-3.5].</u></b> )
		No	Troubleshooting completed.

### DTC P115E [MZI-3.5]

#### DTC P115E (MZI-3.5) DETECTION CONDITION AND POSSIBLE CAUSES

DTC P115E	Throttle actuator control throttle body air flow trim at max limit
<b>DETECTION CONDITION</b>	<ul style="list-style-type: none"> <li>• During idle, the PCM monitors the throttle angle and air flow. If the air flow is determined to be less than expected, the PCM adjusts the throttle angle to compensate. The air flow reduction is typically the result of sludge buildup around the throttle plate. This DTC indicates the PCM has reached the maximum allowed compensation and is no longer able to compensate for the build up.</li> </ul>

## 2007 Mazda CX-9 Grand Touring

2007 ENGINE PERFORMANCE On-Board Diagnostic (MZI-3.5) - CX-9

<b>POSSIBLE CAUSE</b>	<ul style="list-style-type: none"> <li>• Sludge around the throttle plate</li> </ul>
-----------------------	--

### DIAGNOSTIC PROCEDURE

#### DTC P115E (MZI-3.5) DIAGNOSTIC PROCEDURE

STEP	INSPECTION		ACTION
1	<b>VERIFY FREEZE FRAME DATA HAS BEEN RECORDED</b> <ul style="list-style-type: none"> <li>• Has FREEZE FRAME DATA been recorded?</li> </ul>	Yes	Go to the next step.
		No	Record FREEZE FRAME DATA on the repair order, then go to the next step.
2	<b>VERIFY RELATED REPAIR INFORMATION AVAILABILITY</b> <ul style="list-style-type: none"> <li>• Verify related Service Bulletins and/or on-line repair information availability.</li> <li>• Is any related Service Bulletins available?</li> </ul>	Yes	Perform repair or diagnosis according to the available Service Bulletins. <ul style="list-style-type: none"> <li>• If the vehicle is not repaired, go to the next step.</li> </ul>
		No	Go to the next step.
3	<b>INSPECT FOR OTHER POWERTRAIN DTCs</b> <ul style="list-style-type: none"> <li>• Repair all other powertrain DTCs before P115E.</li> <li>• Have all other powertrain DTCs been diagnosed?</li> </ul>	Yes	Go to the next step.
		No	Go to the appropriate DTC Troubleshooting.
4	<b>INSPECT THROTTLE BODY</b> <ul style="list-style-type: none"> <li>• Remove the air duct from the throttle valve body.</li> <li>• Check around the throttle plate for sludge.</li> <li>• Is the throttle valve normal?</li> </ul>	Yes	Replace the throttle body. Then go to the Step 6.
		No	Clean the throttle plate and throttle valve body. Then go to the next step.
5	<b>PERFORM KOER SELF-TEST</b> <ul style="list-style-type: none"> <li>• Verify that all disconnected connectors are reconnected.</li> <li>• Clear the DTC from the PCM memory using the M-MDS.</li> <li>• Perform the KOER self-test.</li> <li>• Retrieve DTCs using the M-MDS.</li> <li>• Is the PENDING CODE for this DTC present?</li> </ul>	Yes	Replace the throttle body then go to the step.
		No	Go to the next step.



## 2007 Mazda CX-9 Grand Touring

2007 ENGINE PERFORMANCE On-Board Diagnostic (MZI-3.5) - CX-9

6	<b>VERIFY TROUBLESHOOTING OF DTC P115E HAS BEEN COMPLETED</b> <ul style="list-style-type: none"> <li>• Verify that all disconnected connectors reconnected.</li> <li>• Turn the ignition switch to the ON position (Engine off).</li> <li>• Clear the DTC from the PCM memory using the M-MDS.</li> <li>• Start the engine and run it at idle.</li> <li>• Retrieve DTCs using the M-MDS.</li> <li>• Is the PENDING CODE for this DTC present?</li> </ul>	Yes	Replace the PCM, then go to the next step. (see <b><u>PCM REMOVAL/INSTALLATION [MZI-3.5]</u></b> .)
		No	Go to the next step.
7	<b>VERIFY AFTER REPAIR PROCEDURE</b> <ul style="list-style-type: none"> <li>• Perform "AFTER REPAIR PROCEDURE".</li> </ul> <p style="text-align: center;">(See <b><u>AFTER REPAIR PROCEDURE [MZI-3.5]</u></b>.)</p> <ul style="list-style-type: none"> <li>• Are any DTC present?</li> </ul>	Yes	Go to the applicable DTC inspection. (See <b><u>DTC TABLE [MZI-3.5]</u></b> .)
		No	Troubleshooting completed.

### DTC P1260 [MZI-3.5]

#### DTC P1260 (MZI-3.5) DETECTION CONDITION AND POSSIBLE CAUSES

<b>DTC P1260</b>	<b>Theft detected, vehicle immobilized</b>
<b>DETECTION CONDITION</b>	Indicates that the PATS determined a theft condition existed and the engine is disabled. This DTC is a good indicator to check the PATS for DTCs.
<b>POSSIBLE CAUSE</b>	<ul style="list-style-type: none"> <li>• Previous theft condition</li> <li>• Anti-theft system failure Theft indicator flashing rapidly or on solid when the ignition switch is in the ON position.</li> <li>• Check the anti-theft system for DTCs.</li> </ul>

#### DIAGNOSTIC PROCEDURE

#### DTC P1260 (MZI-3.5) DIAGNOSTIC PROCEDURE

STEP	INSPECTION		ACTION
1	<b>VERIFY FREEZE FRAME DATA HAS BEEN RECORDED</b>	Yes	Go to the next step.
		No	Record FREEZE FRAME DATA on the

## 2007 Mazda CX-9 Grand Touring

2007 ENGINE PERFORMANCE On-Board Diagnostic (MZI-3.5) - CX-9

	<ul style="list-style-type: none"> <li>Has FREEZE FRAME DATA been recorded?</li> </ul>		repair order, then go to the next step.
2	<b>VERIFY RELATED REPAIR INFORMATION AVAILABILITY</b> <ul style="list-style-type: none"> <li>Verify related Service Bulletins and/or on-line repair information availability.</li> <li>Is any related Service Bulletins available?</li> </ul>	Yes	Perform repair or diagnosis according to the available Service Bulletins. <ul style="list-style-type: none"> <li>If the vehicle is not repaired, go to the next step.</li> </ul>
		No	Go to the next step.
3	<b>INSPECT ALL OTHER PATS DTCs</b> <ul style="list-style-type: none"> <li>Repair all other PATS DTCs before P1260.</li> </ul> (see <b><u>IMMOBILIZER SYSTEM COMPONENT REPLACEMENT/KEY ADDITION AND CLEARING [ADVANCED KEYLESS SYSTEM]</u></b> .)  (see <b><u>IMMOBILIZER SYSTEM COMPONENT REPLACEMENT/KEY ADDITION AND CLEARING [KEYLESS ENTRY SYSTEM]</u></b> .)  <ul style="list-style-type: none"> <li>Have all other PATS DTCs been diagnosed?</li> </ul>	Yes	Go to the next step.
		No	(see <b><u>IMMOBILIZER SYSTEM COMPONENT REPLACEMENT/KEY ADDITION AND CLEARING [ADVANCED KEYLESS SYSTEM]</u></b> .) (see <b><u>IMMOBILIZER SYSTEM COMPONENT REPLACEMENT/KEY ADDITION AND CLEARING [KEYLESS ENTRY SYSTEM]</u></b> .)
4	<b>INSPECT FOR OTHER POWERTRAIN DTCs</b> <ul style="list-style-type: none"> <li>Repair all other powertrain DTCs before P1260.</li> <li>Have all other powertrain DTCs been diagnosed?</li> </ul>	Yes	Go to the next step.
		No	Go to the appropriate DTC troubleshooting.
5	<b>ATTEMPT TO START ENGINE</b> <ul style="list-style-type: none"> <li>Complete the keep alive memory.</li> <li>Reset to clear DTC 1260.</li> <li>This reset initializes the PCM to communicate with the PATS.</li> <li>Attempt to start the engine.</li> </ul>	Yes	No system malfunctions exists at this time. For intermittent No Starts or Start Stalls, verify intermittent PATS faults. Then go to the next step.  <b>NOTE:</b> <ul style="list-style-type: none"> <li><b>PATS cannot stall the engine after</b></li> </ul>

## 2007 Mazda CX-9 Grand Touring

2007 ENGINE PERFORMANCE On-Board Diagnostic (MZI-3.5) - CX-9

	<ul style="list-style-type: none"> <li>Does the engine start?</li> </ul>		<p><b>1 second of operation. For intermittent Stalls while driving, verify the M-MDS tester to PCM communication during concern. If a PCM communication error occurs, possible causes are:</b></p> <ul style="list-style-type: none"> <li>Loss of PWRs or grounds to the PCM.</li> <li>Malfunctioning PCM PWR relay.</li> <li>Malfunctioning EEC PWR diode.</li> </ul> <ul style="list-style-type: none"> <li><b>Repair if necessary and return the vehicle to customer.</b></li> </ul>
		No	<p>DTC P1260 is not the cause of the No Start. (see <b><u>QUICK DIAGNOSTIC CHART [MZI-3.5]</u></b> .)</p>
6	<p><b>VERIFY TROUBLESHOOTING OF DTC P1260 HAS BEEN COMPLETED</b></p> <ul style="list-style-type: none"> <li>Verify that all disconnected connectors are reconnected.</li> <li>Turn the ignition switch to the ON position (Engine off).</li> <li>Clear the DTC from the PCM memory using the M-MDS.</li> <li>Start the engine and run it at idle.</li> <li>Retrieve DTCs using the M-MDS,</li> <li>Is the PENDING CODE for this DTC present?</li> </ul>	Yes	<p>Replace the PCM, then go to the next step. (see <b><u>PCM REMOVAL/INSTALLATION [MZI-3.5]</u></b> .)</p>
		No	<p>Go to the next step.</p>
7	<p><b>VERIFY AFTER REPAIR PROCEDURE</b></p> <ul style="list-style-type: none"> <li>Perform "AFTER REPAIR PROCEDURE".</li> </ul> <p>(See <b><u>AFTER REPAIR PROCEDURE [MZI-3.5]</u></b>.)</p> <ul style="list-style-type: none"> <li>Are any DTC present?</li> </ul>	Yes	<p>Go to the applicable DTC inspection. (See <b><u>DTC TABLE [MZI-3.5]</u></b>.)</p>
		No	<p>Troubleshooting completed.</p>

### DTC P1285, P1299 [MZI-3.5]

#### DTC P1285, P1299 (MZI-3.5) DETECTION CONDITION AND POSSIBLE CAUSES

## 2007 Mazda CX-9 Grand Touring

2007 ENGINE PERFORMANCE On-Board Diagnostic (MZI-3.5) - CX-9

<b>DTC P1285</b>	<b>P1285: Cylinder head over temperature condition</b>
<b>DTC P1299</b>	<b>P1299: Cylinder head over temperature protection active</b>
<b>DETECTION CONDITION</b>	<ul style="list-style-type: none"> <li>• P1285 indicates that an engine overheat condition was sensed by the CHT sensor.</li> <li>• P1299 indicates that an engine overheat condition was detected by the CHT sensor.</li> <li>• Fail-safe function was activated to cool the engine.</li> </ul>
<b>POSSIBLE CAUSE</b>	<ul style="list-style-type: none"> <li>• Low engine coolant level</li> <li>• Base engine malfunction</li> <li>• Engine cooling system malfunction</li> <li>• CHT sensor malfunction</li> </ul>

### DIAGNOSTIC PROCEDURE

#### DTC P1285, P1299 (MZI-3.5) DIAGNOSTIC PROCEDURE

STEP	INSPECTION	ACTION	
1	<b>VERIFY FREEZE FRAME DATA HAS BEEN RECORDED</b>	Yes	Go to the next step.
	<ul style="list-style-type: none"> <li>• Has FREEZE FRAME DATA been recorded?</li> </ul>	No	Record FREEZE FRAME DATA on the repair order, then go to the next step.
2	<b>VERIFY RELATED REPAIR INFORMATION AVAILABILITY</b>	Yes	Perform repair or diagnosis according to the available Service Bulletins. <ul style="list-style-type: none"> <li>• If the vehicle is not repaired, go to the next step.</li> </ul>
	<ul style="list-style-type: none"> <li>• Verify related Service Bulletins and/or on-line repair information availability.</li> <li>• Is any related Service Bulletins available?</li> </ul>	No	Go to the next step.
3	<b>INSPECT COOLING SYSTEM</b>  <b>WARNING:</b> <ul style="list-style-type: none"> <li>• Never remove the cooling system cap or loosen the radiator drain plug while the engine is running, or when the engine and radiator are hot. Scalding engine coolant and steam may shoot out and cause serious injury. It may also damage the engine and cooling system.</li> <li>• Turn off the engine and wait until it is cool. Even then, be</li> </ul>	Yes	Go to the next step.

## 2007 Mazda CX-9 Grand Touring

2007 ENGINE PERFORMANCE On-Board Diagnostic (MZI-3.5) - CX-9

	<p><b>very careful when removing the cap. Wrap a thick cloth around it and slowly turn it counterclockwise to the first stop. Step back while the pressure escapes.</b></p> <ul style="list-style-type: none"> <li>• <b>When you are sure all the pressure is gone, press down on the cap using the cloth, turn it, and remove it.</b></li> </ul> <p><b>NOTE:</b></p> <ul style="list-style-type: none"> <li>• <b>If the electric cooling fan does not operate, go to the applicable DTC inspection. (See <u>DTC TABLE [MZI-3.5].</u>)</b></li> <li>• An engine overheat condition is sensed by the CHT sensor.</li> <li>• Check the cooling system for: <ul style="list-style-type: none"> <li>○ Correct coolant level</li> <li>○ Internal or external coolant leaks</li> <li>○ Blockage of the radiator</li> <li>○ Cooling fan operation</li> </ul> </li> <li>• Is the cooling system normal?</li> </ul>	No	Repair if necessary. Then go to the next step.
4	<p><b>INSPECT OPERATION OF THE CHT SENSOR</b></p> <ul style="list-style-type: none"> <li>• Run the engine until the engine temperature stabilizes.</li> <li>• Verify the radiator hoses are hot and the cooling system is pressurized.</li> <li>• Verify self-test DTCs.</li> <li>• Is DTC P1285 present?</li> </ul>	Yes	Go to the next step.
		No	An engine overheat temperature was not detected. Repair any other DTCs if necessary.
5	<p><b>INSPECT CHT SENSOR</b></p> <ul style="list-style-type: none"> <li>• Inspect the CHT sensor.</li> </ul> <p>(see <u>CYLINDER HEAD TEMPERATURE (CHT) SENSOR INSPECTION [MZI-3.5].</u>)</p>	Yes	Replace the CHT sensor, then go to the next step.
		No	Go to the next step.

## 2007 Mazda CX-9 Grand Touring

2007 ENGINE PERFORMANCE On-Board Diagnostic (MZI-3.5) - CX-9

	<ul style="list-style-type: none"> <li>• Is there any malfunction?</li> </ul>		
6	<b>VERIFY TROUBLESHOOTING OF DTC P1285, P1299 HAS BEEN COMPLETED</b> <ul style="list-style-type: none"> <li>• Verify that all disconnected connectors are reconnected.</li> <li>• Turn the ignition switch to the ON position (Engine off).</li> <li>• Clear the DTC from the PCM memory using the M-MDS.</li> <li>• Start the engine and run it at idle.</li> <li>• Retrieve DTCs using the M-MDS.</li> <li>• Is the PENDING CODE for this DTC present?</li> </ul>	Yes	Replace the PCM, then go to the next step. (see <b>PCM REMOVAL/INSTALLATION [MZI-3.5]</b> .)
		No	Go to the next step.
7	<b>VERIFY AFTER REPAIR PROCEDURE</b> <ul style="list-style-type: none"> <li>• Perform the "AFTER REPAIR PROCEDURE".</li> </ul> <p>(See <b>AFTER REPAIR PROCEDURE [MZI-3.5]</b>.)</p> <ul style="list-style-type: none"> <li>• Are any DTC present?</li> </ul>	Yes	Go to the applicable DTC inspection. (See <b>DTC TABLE [MZI-3.5]</b> .)
		No	Troubleshooting completed.

### DTC P1288 [MZI-3.5]

#### DTC P1288 (MZI-3.5) DETECTION CONDITION AND POSSIBLE CAUSES

<b>DTC P1288</b>	<b>CHT sensor out of self-test range</b>
<b>DETECTION CONDITION</b>	<ul style="list-style-type: none"> <li>• Indicates the CHT sensor is out of self-test range. The engine is not at a normal operating temperature.</li> </ul>
<b>POSSIBLE CAUSE</b>	<ul style="list-style-type: none"> <li>• Cold engine</li> <li>• Engine overheating</li> <li>• Connector or terminal malfunction</li> <li>• Low engine coolant level</li> <li>• CHT sensor malfunction</li> </ul>

#### DIAGNOSTIC PROCEDURE

#### DTC P1288 (MZI-3.5) DIAGNOSTIC PROCEDURE

STEP	INSPECTION	ACTION

## 2007 Mazda CX-9 Grand Touring

2007 ENGINE PERFORMANCE On-Board Diagnostic (MZI-3.5) - CX-9

1	<b>VERIFY FREEZE FRAME DATA HAS BEEN RECORDED</b> <ul style="list-style-type: none"> <li>• Has FREEZE FRAME DATA been recorded?</li> </ul>	Yes	Go to next step.
		No	Record FREEZE FRAME DATA on the repair order, then go to next step.
2	<b>VERIFY RELATED REPAIR INFORMATION AVAILABILITY</b> <ul style="list-style-type: none"> <li>• Verify related Service Bulletins availability.</li> <li>• Is any related Service Bulletins available?</li> </ul>	Yes	Perform repair or diagnosis according to available Service Bulletins. <ul style="list-style-type: none"> <li>• If vehicle is not repaired, go to next step.</li> </ul>
		No	Go to next step.
3	<b>VERIFY RELATED PENDING CODE OR STORED DTC</b> <ul style="list-style-type: none"> <li>• Verify the related PENDING CODE or stored DTCs.</li> <li>• Are other DTCs present?</li> </ul>	Yes	Go to appropriate DTC inspection. (See <b><u>DTC TABLE [MZI-3.5]</u></b> .)
		No	Go to the next step.
4	<b>INSPECT THE COOLING SYSTEM</b> <ul style="list-style-type: none"> <li>• Inspect the vehicle coolant level.</li> <li>• Is the cooling system normal?</li> </ul>	Yes	Go to the next step.
		No	Inspect the cooling system (overheat), the go to Step 7.
5	<b>INSPECT CHT SENSOR</b> <ul style="list-style-type: none"> <li>• Inspect the CHT sensor.</li> </ul> <p style="margin-left: 20px;">(see <b><u>CYLINDER HEAD TEMPERATURE (CHT) SENSOR INSPECTION [MZI-3.5]</u></b>.)</p> <ul style="list-style-type: none"> <li>• Is there any malfunction?</li> </ul>	Yes	Replace the CHT sensor, then go to Step 7.
		No	Go to the next step.
6	<b>INSPECT FOR CORRECT PCM OPERATION</b> <ul style="list-style-type: none"> <li>• Disconnect all the PCM connectors.</li> <li>• Visually inspect for:               <ul style="list-style-type: none"> <li>○ Pushed out pins</li> <li>○ Corrosion</li> </ul> </li> <li>• Connect all the PCM connectors and verify that they seat correctly.</li> <li>• Retrieve DTCs using the M-MDS.</li> <li>• Is the PENDING CODE for this</li> </ul>	Yes	Go to the next step.
		No	The system is correctly. Go to the next step.

## 2007 Mazda CX-9 Grand Touring

2007 ENGINE PERFORMANCE On-Board Diagnostic (MZI-3.5) - CX-9

DTC present?			
7	<b>VERIFY TROUBLESHOOTING OF DTC P1288 HAS BEEN COMPLETED</b> <ul style="list-style-type: none"> <li>• Verify that all disconnected connectors reconnected.</li> <li>• Clear the DTC from the PCM memory using the M-MDS.</li> <li>• Perform the KOEO or KOER self-test using the M-MDS.</li> </ul> <p>(See <b>KOEO/KOER SELF TEST [MZI-3.5].</b>)</p> <ul style="list-style-type: none"> <li>• Is the PENDING CODE for the DTC present?</li> </ul>	Yes	Replace the PCM, then go to the next step. (see <b>PCM REMOVAL/INSTALLATION [MZI-3.5]</b> .)
		No	Go to the next step.
8	<b>VERIFY AFTER REPAIR PROCEDURE</b> <ul style="list-style-type: none"> <li>• Perform "AFTER REPAIR PROCEDURE".</li> </ul> <p>(See <b>AFTER REPAIR PROCEDURE [MZI-3.5].</b>)</p> <ul style="list-style-type: none"> <li>• Are any DTCs present?</li> </ul>	Yes	Go to the applicable DTC inspection. (See <b>DTC TABLE [MZI-3.5].</b> )
		No	Troubleshooting completed.

### DTC P1289 [MZI-3.51]

#### DTC P1289 (MZI-3.5) DETECTION CONDITION AND POSSIBLE CAUSES

DTC P1289	CHT sensor circuit high input
<b>DETECTION CONDITION</b>	<ul style="list-style-type: none"> <li>• Indicates a CHT sensor circuit open.</li> </ul>
<b>POSSIBLE CAUSE</b>	<ul style="list-style-type: none"> <li>• Open circuit in wiring harness between CHT sensor terminal A and PCM terminal 2AN</li> <li>• Open circuit in wiring harness between CHT sensor terminal B and PCM terminal 2AN</li> <li>• Short to power supply in wiring harness between CHT sensor terminal B and PCM terminal 2AN</li> <li>• CHT sensor malfunction</li> <li>• Connector or terminal malfunction</li> </ul>



## 2007 Mazda CX-9 Grand Touring

2007 ENGINE PERFORMANCE On-Board Diagnostic (MZI-3.5) - CX-9

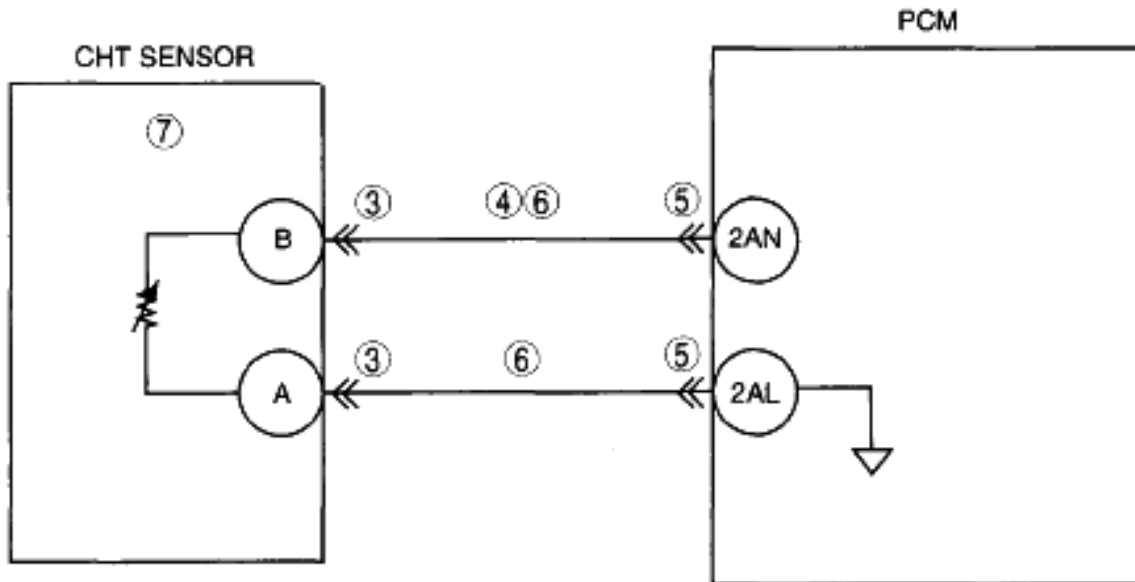

CHT SENSOR  
WIRING HARNESS-SIDE CONNECTOR



PCM  
WIRING HARNESS-SIDE CONNECTOR

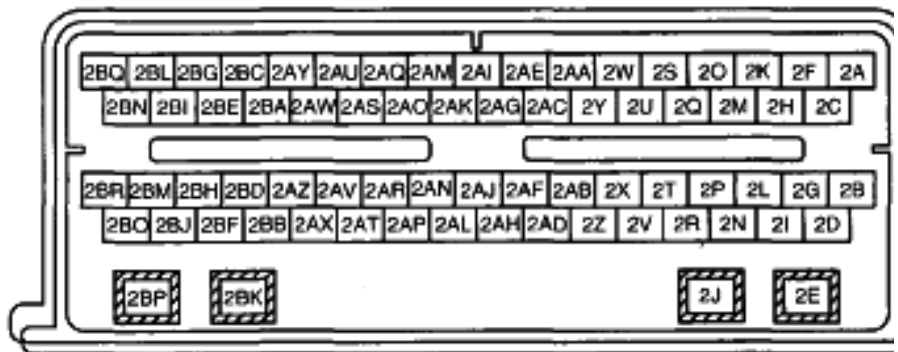

### DIAGNOSTIC PROCEDURE

#### DTC P1289 (MZI-3.5) DIAGNOSTIC PROCEDURE

STEP	INSPECTION		ACTION
1	<b>VERIFY FREEZE FRAME DATA HAS BEEN RECORDED</b> <ul style="list-style-type: none"> <li>Has FREEZE FRAME DATA been recorded?</li> </ul>	Yes	Go to the next step.
		No	Record FREEZE FRAME DATA on the repair order, then go to the next step.

## 2007 Mazda CX-9 Grand Touring

2007 ENGINE PERFORMANCE On-Board Diagnostic (MZI-3.5) - CX-9

2	<b>VERIFY RELATED REPAIR INFORMATION AVAILABILITY</b> <ul style="list-style-type: none"> <li>• Verify related Service Bulletins and/or on-line repair information availability.</li> <li>• is any related Service Bulletins available?</li> </ul>	Yes	Perform repair or diagnosis according to the available Service Bulletins. <ul style="list-style-type: none"> <li>• If the vehicle is not repaired, go to the next step.</li> </ul>
		No	Go to the next step.
3	<b>INSPECT POOR CONNECTION OF CHT SENSOR CONNECTOR</b> <ul style="list-style-type: none"> <li>• Turn the ignition switch off.</li> <li>• Disconnect CHT sensor connector.</li> <li>• Inspect for poor connection (such as damaged/pulled-out pins, corrosion).</li> <li>• Are there any malfunction?</li> </ul>	Yes	Repair or replace suspected part, then go to Step 8.
		No	Go to the next step.
4	<b>INSPECT CHT SENSOR SIGNAL CIRCUIT FOR SHORT TO POWER SUPPLY</b> <ul style="list-style-type: none"> <li>• Turn the ignition switch to the ON position (Engine off).</li> <li>• Measure the voltage between CHT sensor terminal B (wiring harness-side) and body ground.</li> <li>• Is the voltage <b>B+</b> ?</li> </ul>	Yes	Repair or replace suspected part, then go to Step 8.
		No	Go to the next step.
5	<b>INSPECT PCM CONNECTOR FOR POOR CONNECTION</b> <ul style="list-style-type: none"> <li>• Disconnect the PCM connector.</li> <li>• Inspect for poor connection (such as damaged/pulled-out pins, corrosion).</li> <li>• Are there any malfunction?</li> </ul>	Yes	Repair or replace suspected part, then go to Step 8.
		No	Go to the next step.
6	<b>INSPECT CHT SENSOR CIRCUIT FOR OPEN CIRCUIT</b> <ul style="list-style-type: none"> <li>• Inspect the continuity between the following circuit:                             <ul style="list-style-type: none"> <li>○ CHT sensor terminal A (wiring harness-side) and PCM terminal 2AL (wiring harness-side).</li> </ul> </li> </ul>	Yes	Go to the next step.
		No	Repair or replace suspected part, then go to Step 8.

## 2007 Mazda CX-9 Grand Touring

2007 ENGINE PERFORMANCE On-Board Diagnostic (MZI-3.5) - CX-9

	<ul style="list-style-type: none"> <li>○ CHT sensor terminal B (wiring harness-side) and PCM terminal 2AN (wiring harness-side).</li> <li>● Are there continuity?</li> </ul>		
7	<p><b>INSPECT CHT SENSOR</b></p> <ul style="list-style-type: none"> <li>● Inspect the CHT sensor.</li> </ul> <p>(see <b><u>CYLINDER HEAD TEMPERATURE (CHT) SENSOR INSPECTION [MZI-3.5]</u></b>.)</p> <ul style="list-style-type: none"> <li>● Is there any malfunction?</li> </ul>	Yes	Replace the CHT sensor, then go to the next step.
		No	Go to the next step.
8	<p><b>VERIFY TROUBLESHOOTING OF DTC P1289 HAS BEEN COMPLETED</b></p> <ul style="list-style-type: none"> <li>● Verify that all disconnected connectors reconnected.</li> <li>● Clear the DTC from the PCM memory using the M-MDS.</li> <li>● Perform the KOEO or KOER self-test using the M-MDS.</li> </ul> <p>(See <b><u>KOEO/KOER SELF TEST [MZI-3.5]</u></b>.)</p> <ul style="list-style-type: none"> <li>● Is the PENDING CODE for the DTC present?</li> </ul>	Yes	Replace the PCM, then go to the next step. (see <b><u>PCM REMOVAL/INSTALLATION [MZI-3.5]</u></b> .)
		No	Go to the next step.
9	<p><b>VERIFY AFTER REPAIR PROCEDURE</b></p> <ul style="list-style-type: none"> <li>● Perform "AFTER REPAIR PROCEDURE".</li> </ul> <p>(See <b><u>AFTER REPAIR PROCEDURE [MZI-3.5]</u></b>.)</p> <ul style="list-style-type: none"> <li>● Are any DTCs present?</li> </ul>	Yes	Go to the applicable DTC inspection. (See <b><u>DTC TABLE [MZI-3.5]</u></b> .)
		No	Troubleshooting completed.

### DTC P1290 [MZI-3.5]

#### DTC P1290 (MZI-3.5) DETECTION CONDITION AND POSSIBLE CAUSES

## 2007 Mazda CX-9 Grand Touring

2007 ENGINE PERFORMANCE On-Board Diagnostic (MZI-3.5) - CX-9

<b>DTC P1290</b>	<b>CHT sensor circuit low input</b>
<b>DETECTION CONDITION</b>	<ul style="list-style-type: none"> <li>• Indicates a CHT sensor circuit short to ground.</li> </ul>
<b>POSSIBLE CAUSE</b>	<ul style="list-style-type: none"> <li>• Short to ground in wiring harness between CHT sensor terminal B and PCM term 2AN</li> <li>• CHT sensor malfunction</li> <li>• Connector or terminal malfunction</li> </ul>

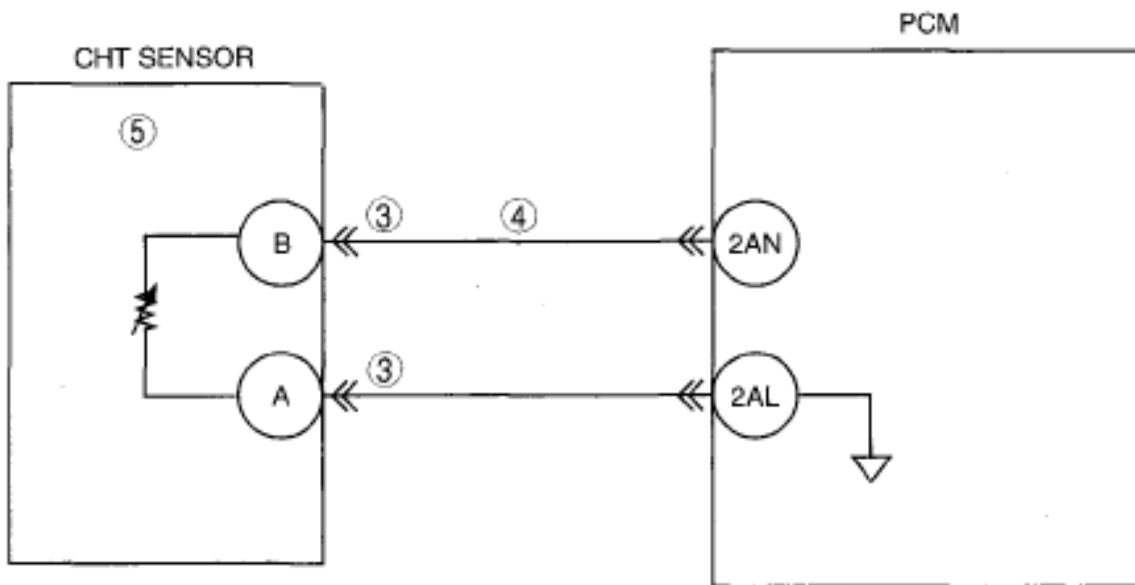

CHT SENSOR  
WIRING HARNESS-SIDE CONNECTOR

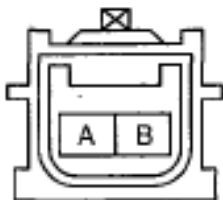

PCM  
WIRING HARNESS-SIDE CONNECTOR

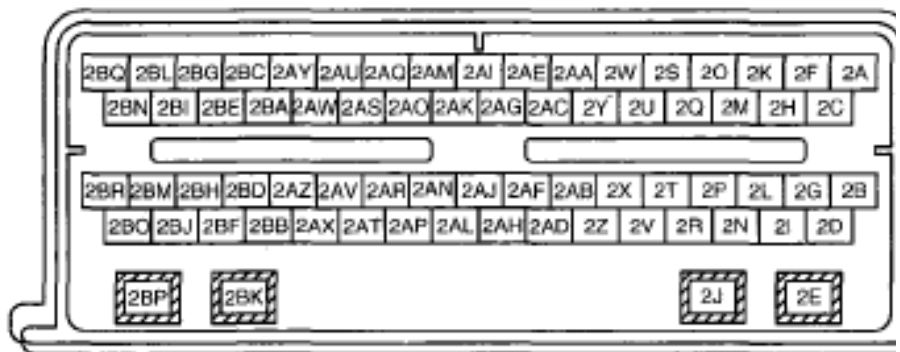

### DIAGNOSTIC PROCEDURE

## 2007 Mazda CX-9 Grand Touring

2007 ENGINE PERFORMANCE On-Board Diagnostic (MZI-3.5) - CX-9

### DTC P1290 (MZI-3.5) DIAGNOSTIC PROCEDURE

STEP	INSPECTION	ACTION	
1	<b>VERIFY FREEZE FRAME DATA HAS BEEN RECORDED</b> <ul style="list-style-type: none"> <li>• Has FREEZE FRAME DATA been recorded?</li> </ul>	Yes	Go to the next step.
		No	Record FREEZE FRAME DATA on the repair order, then go to the next step.
2	<b>VERIFY RELATED REPAIR INFORMATION AVAILABILITY</b> <ul style="list-style-type: none"> <li>• Verify related Service Bulletins and/or on-line repair information availability.</li> <li>• Is any related Service Bulletins available?</li> </ul>	Yes	Perform repair or diagnosis according to the available Service Bulletins. <ul style="list-style-type: none"> <li>• If the vehicle is not repaired, go to the next step.</li> </ul>
		No	Go to the next step.
3	<b>INSPECT TERMINAL BENT</b> <ul style="list-style-type: none"> <li>• Turn the ignition switch off.</li> <li>• Disconnect the CHT sensor connector.</li> <li>• Inspect for bent of CHT sensor terminals A and B (part-side).</li> <li>• Is there any malfunction?</li> </ul>	Yes	Repair or replace the terminal, then go to Step 6.
		No	Go to the next step.
4	<b>INSPECT CHT SENSOR SIGNAL CIRCUIT FOR SHORT TO GROUND</b> <ul style="list-style-type: none"> <li>• Turn the ignition switch off.</li> <li>• Inspect for continuity between CHT sensor terminal B (wiring harness-side) and body ground.</li> <li>• Is there continuity?</li> </ul>	Yes	Repair or replace suspected part, then go to Step 6.
		No	Go to the next step.
5	<b>INSPECT CHT SENSOR</b> <ul style="list-style-type: none"> <li>• Inspect the CHT sensor.</li> </ul> <p style="text-align: center;">(see <b><u>CYLINDER HEAD TEMPERATURE (CHT) SENSOR INSPECTION [MZI-3.5]</u></b>.)</p> <ul style="list-style-type: none"> <li>• Is there any malfunction?</li> </ul>	Yes	Replace the CHT sensor, then go to the next step.
		No	Go to the next step.
6	<b>VERIFY TROUBLESHOOTING OF DTC P1290 HAS BEEN</b>	Yes	Replace the PCM, then go to the next step. (see <b><u>PCM</u></b> )

## 2007 Mazda CX-9 Grand Touring

2007 ENGINE PERFORMANCE On-Board Diagnostic (MZI-3.5) - CX-9

	<p><b>COMPLETED</b></p> <ul style="list-style-type: none"> <li>• Verify that all disconnected connectors reconnected.</li> <li>• Clear the DTC from the PCM memory using the M-MDS.</li> <li>• Perform the KOEO or KOER self-test using the M-MDS.</li> </ul> <p>(See <b><u>KOEO/KOER SELF TEST [MZI-3.5].</u></b>)</p> <ul style="list-style-type: none"> <li>• Is the PENDING CODE for the DTC present?</li> </ul>		<p><b>REMOVAL/INSTALLATION [MZI-3.5] .)</b></p>
		No	Go to the next step.
7	<p><b>VERIFY AFTER REPAIR PROCEDURE</b></p> <ul style="list-style-type: none"> <li>• Perform "AFTER REPAIR PROCEDURE".</li> </ul> <p>(See <b><u>AFTER REPAIR PROCEDURE [MZI-3.5].</u></b>)</p> <ul style="list-style-type: none"> <li>• Are any DTCs present?</li> </ul>	Yes	Go to the applicable DTC inspection. (See <b><u>DTC TABLE [MZI-3.5].</u></b> )
		No	Troubleshooting completed.

### DTC P1336 [MZI-3.5]

#### DTC P1336 (MZI-3.5) DETECTION CONDITION AND POSSIBLE CAUSES

<b>DTC P1336</b>	<b>CKP/CMP sensor range/performance</b>
<b>DETECTION CONDITION</b>	<ul style="list-style-type: none"> <li>• The input signal to the PCM from the CKP sensor or the CMP sensor is erratic.</li> </ul>
<b>POSSIBLE CAUSE</b>	<ul style="list-style-type: none"> <li>• CKP sensor malfunction</li> <li>• CMP sensor malfunction</li> <li>• Base engine malfunction</li> <li>• Connector or terminal malfunction</li> </ul>

#### DIAGNOSTIC PROCEDURE

##### DTC P1336 (MZI-3.5) DIAGNOSTIC PROCEDURE

STEP	INSPECTION		ACTION
1	<b>VERIFY FREEZE FRAME DATA HAS BEEN RECORDED</b>	Yes	Go to the next step.
		No	Record FREEZE FRAME DATA on the

## 2007 Mazda CX-9 Grand Touring

2007 ENGINE PERFORMANCE On-Board Diagnostic (MZI-3.5) - CX-9

	<ul style="list-style-type: none"> <li>Has FREEZE FRAME DATA been recorded?</li> </ul>		repair order, then go to the next step.
2	<b>VERIFY RELATED REPAIR INFORMATION AVAILABILITY</b> <ul style="list-style-type: none"> <li>Verify related Service Bulletins and/or on-line repair information availability.</li> <li>Is any related Service Bulletins available?</li> </ul>	Yes	Perform repair or diagnosis according to the available Service Bulletins. <ul style="list-style-type: none"> <li>If the vehicle is not repaired, go to the next step.</li> </ul>
		No	Go to the next step.
3	<b>VERIFY RELATED PENDING CODE OR STORED DTC</b> <ul style="list-style-type: none"> <li>Verify the related PENDING CODE or stored DTCs.</li> <li>Are other DTCs present?</li> </ul>	Yes	Go to appropriate DTC inspection. (See <b><u>DTC TABLE [MZI-3.5]</u></b> .)
		No	Go to the next step.
4	<b>INSPECT THE CKP SENSOR SIGNAL SENT TO THE PCM</b> <p><b>NOTE:</b></p> <ul style="list-style-type: none"> <li>The battery should be fully charged and the starting system should be functioning properly.</li> <li>Connect the M-MDS to the DLC-2.</li> <li>Access RPM PID.</li> <li>Crank the engine.</li> <li>Is the reading <b>more than 150 rpm</b> ?</li> </ul>	Yes	Go to Step 8.
		No	Go to the next step.
5	<b>INSPECT THE FRONT COVER, CKP SENSOR AND CKP SENSOR PULSE WHEEL FOR OBVIOUS PHYSICAL DAMAGE</b> <ul style="list-style-type: none"> <li>Turn the ignition switch off.</li> <li>Visually inspect the front cover, CKP sensor and CKP sensor pulse wheel for obvious physical damage.</li> <li>Do any parts appear physically damaged?</li> </ul>	Yes	Repair if necessary, then go to Step 11.
		No	Go to the next step.
6	<b>INSPECT CKP SENSOR CONNECTOR FOR POOR</b>	Yes	Repair or replace suspected part, then go to Step 11.

## 2007 Mazda CX-9 Grand Touring

2007 ENGINE PERFORMANCE On-Board Diagnostic (MZI-3.5) - CX-9

	<p><b>CONNECTION</b></p> <ul style="list-style-type: none"> <li>• Disconnect the CKP sensor connector.</li> <li>• Inspect for poor connection (such as damaged/pulled-out pins, corrosion).</li> <li>• Is there any malfunction?</li> </ul>	No	Go to the next step.
7	<p><b>INSPECT CKP SENSOR</b></p> <ul style="list-style-type: none"> <li>• Inspect the CKP sensor.</li> </ul> <p>(see <b><u>CRANKSHAFT POSITION (CKP) SENSOR INSPECTION [MZI-3.5].</u></b>)</p> <ul style="list-style-type: none"> <li>• Is there any malfunction?</li> </ul>	Yes	Replace the CKP sensor, then go to Step 11. (see <b><u>CRANKSHAFT POSITION (CKP) SENSOR REMOVAL/INSTALLATION [MZI-3.5].</u></b> )
		No	Go to the next step.
8	<p><b>INSPECT CMP SENSOR CONNECTOR FOR POOR CONNECTION</b></p> <ul style="list-style-type: none"> <li>• Disconnect the CMP sensor connector.</li> <li>• Inspect for poor connection (such as damaged/pulled-out pins, corrosion).</li> <li>• Is there any malfunction?</li> </ul>	Yes	Repair or replace suspected part, then go to Step 11.
		No	Go to the next step.
9	<p><b>INSPECT CMP SENSOR</b></p> <ul style="list-style-type: none"> <li>• Inspect the CMP sensor.</li> </ul> <p>(see <b><u>CAMSHAFT POSITION (CMP) SENSOR INSPECTION [MZI-3.5].</u></b>)</p> <ul style="list-style-type: none"> <li>• Is there any malfunction?</li> </ul>	Yes	Replace the CMP sensor, then go to Step 11. (see <b><u>CAMSHAFT POSITION (CMP) SENSOR REMOVAL/INSTALLATION [MZI-3.5].</u></b> )
		No	Go to the next step.
10	<p><b>INSPECT PCM CONNECTOR FOR POOR CONNECTION</b></p> <ul style="list-style-type: none"> <li>• Disconnect the PCM connector.</li> <li>• Inspect for poor connection (such as damaged/pulled-out pins, corrosion).</li> <li>• Are any malfunction?</li> </ul>	Yes	Repair or replace suspected part, then go to the next step.
		No	Go to the next step.



## 2007 Mazda CX-9 Grand Touring

2007 ENGINE PERFORMANCE On-Board Diagnostic (MZI-3.5) - CX-9

11	<b>VERIFY TROUBLESHOOTING OF DTC P1336 HAS BEEN COMPLETED</b> <ul style="list-style-type: none"> <li>• Make sure to reconnect all disconnected connectors.</li> <li>• Clear the DTC from the PCM memory using the M-MDS.</li> <li>• Start the engine.</li> <li>• Is the same DTC present?</li> </ul>	Yes	Replace the PCM, then go to the next step. (see <b><u>PCM REMOVAL/INSTALLATION [MZI-3.5]</u></b> .)
		No	Go to the next step.
12	<b>VERIFY AFTER REPAIR PROCEDURE</b> <ul style="list-style-type: none"> <li>• Perform the "AFTER REPAIR PROCEDURE".</li> </ul> <p style="text-align: center;">(See <b><u>AFTER REPAIR PROCEDURE [MZI-3.5]</u></b>.)</p> <ul style="list-style-type: none"> <li>• Are any DTCs present?</li> </ul>	Yes	Go to the applicable DTC inspection. (See <b><u>DTC TABLE [MZI-3.5]</u></b> .)
		No	Troubleshooting completed.

### DTC P1397 [MZI-3.5]

#### DTC P1397 (MZI-3.5) DETECTION CONDITION AND POSSIBLE CAUSES

<b>DTC P1397</b>	<b>System voltage out of self-test range</b>
<b>DETECTION CONDITION</b>	<ul style="list-style-type: none"> <li>• This DTC indicates that the 12-volt system voltage is too high or too low during the KOEO or KOER self-test. It sets if the system voltage falls below or exceeds the calibrated threshold at any time during the KOEO or KOER self-test.</li> </ul>
<b>POSSIBLE CAUSE</b>	<ul style="list-style-type: none"> <li>• Battery or charging system concern.</li> </ul>

#### DIAGNOSTIC PROCEDURE

#### DTC P1397 (MZI-3.5) DIAGNOSTIC PROCEDURE

STEP	INSPECTION	ACTION	
1	<b>VERIFY FREEZE FRAME DATA HAS BEEN RECORDED</b> <ul style="list-style-type: none"> <li>• Has FREEZE FRAME DATA been recorded?</li> </ul>	Yes	Go to the next step.
		No	Record FREEZE FRAME DATA on the repair order, then go to the next step.
2	<b>VERIFY RELATED REPAIR INFORMATION AVAILABILITY</b> <ul style="list-style-type: none"> <li>• Verify related Service Bulletins</li> </ul>	Yes	Perform repair or diagnosis according to the available Service Bulletins. <ul style="list-style-type: none"> <li>• If the vehicle is not repaired, go to</li> </ul>

## 2007 Mazda CX-9 Grand Touring

2007 ENGINE PERFORMANCE On-Board Diagnostic (MZI-3.5) - CX-9

	and/or on-line repair information availability. <ul style="list-style-type: none"> <li>Is any related Service Bulletins available?</li> </ul>	No	Go to the next step.
3	<b>INSPECT THE BATTERY</b> <ul style="list-style-type: none"> <li>Turn the ignition switch off.</li> <li>Inspect the battery.</li> <li>Is the battery normal?</li> </ul>	Yes	Inspect charging system. (see <b><u>QUICK DIAGNOSTIC CHART [MZI-3.5]</u></b> .) <ul style="list-style-type: none"> <li>If there is any malfunction, repair or replace malfunctioning part, then go to the next step.</li> </ul>
		No	Replace the battery, then go to the next step.
4	<b>VERIFY TROUBLESHOOTING OF DTC P1397 HAS BEEN COMPLETED</b> <ul style="list-style-type: none"> <li>Verify that all disconnected connectors reconnected.</li> <li>Clear the DTC from the PCM memory using the M-MDS.</li> <li>Perform the KOEO or KOER self-test using the M-MDS.</li> </ul> <p>(See <b><u>KOEO/KOER SELF TEST [MZI-3.5]</u></b>.)</p> <ul style="list-style-type: none"> <li>Is the PENDING CODE for the DTC present?</li> </ul>	Yes	Replace the PCM, then go to the next step. (see <b><u>PCM REMOVAL/INSTALLATION [MZI-3.5]</u></b> .)
		No	Go to the next step.
5	<b>VERIFY AFTER REPAIR PROCEDURE</b> <ul style="list-style-type: none"> <li>Perform "AFTER REPAIR PROCEDURE".</li> </ul> <p>(See <b><u>AFTER REPAIR PROCEDURE [MZI-3.5]</u></b>.)</p> <ul style="list-style-type: none"> <li>Are any DTCs present?</li> </ul>	Yes	Go to the applicable DTC inspection. (See <b><u>DTC TABLE [MZI-3.5]</u></b> .)
		No	Troubleshooting completed.

### DTC P1450 [MZI-3.5]

#### DTC P1450 (MZI-3.5) DETECTION CONDITION AND POSSIBLE CAUSES

DTC P1450	Unable to bleed up fuel tank vacuum
DETECTION	

## 2007 Mazda CX-9 Grand Touring

2007 ENGINE PERFORMANCE On-Board Diagnostic (MZI-3.5) - CX-9

<b>CONDITION</b>	<ul style="list-style-type: none"> <li>• P1450 indicates the Self-Test has detected that the EVAP system is unable to bleed up fuel tank vacuum.</li> </ul>
<b>POSSIBLE CAUSE</b>	<ul style="list-style-type: none"> <li>• Blockages or kinks in the charcoal canister tube or purge solenoid valve outlet tube (between fuel tank, CV solenoid valve and charcoal canister).</li> <li>• Fuel filler cap is stuck closed (no vacuum relief).</li> <li>• Contaminated fuel vapor elbow on charcoal canister.</li> <li>• Restricted charcoal canister.</li> <li>• CV solenoid valve stuck open (partially or fully).</li> <li>• Plugged CV solenoid valve filter.</li> <li>• CV solenoid valve is stuck open.</li> <li>• Power supply open (wiring harness near Fuel tank pressure sensor, Fuel tank pressure sensor or PCM).</li> <li>• Fuel tank pressure sensor malfunction</li> </ul>

### DIAGNOSTIC PROCEDURE

#### DTC P1450 (MZI-3.5) DIAGNOSTIC PROCEDURE

STEP	INSPECTION		ACTION
1	<b>VERIFY FREEZE FRAME DATA HAS BEEN RECORDED</b> <ul style="list-style-type: none"> <li>• Has FREEZE FRAME DATA been recorded?</li> </ul>	Yes	Go to the next step.
		No	Record FREEZE FRAME DATA on the repair order, then go to the next step.
2	<b>VERIFY RELATED REPAIR INFORMATION AVAILABILITY</b> <ul style="list-style-type: none"> <li>• Verify related Service Bulletins and/or on-line repair information availability.</li> <li>• Is any related Service Bulletins available?</li> </ul>	Yes	Perform repair or diagnosis according to the available Service Bulletins. <ul style="list-style-type: none"> <li>• If the vehicle is not repaired, go to the next step.</li> </ul>
		No	Go to the next step.
3	<b>VERIFY RELATED PENDING CODE OR STORED DTCs</b> <ul style="list-style-type: none"> <li>• Turn the ignition switch off then to the ON position (Engine off).</li> <li>• Verify related pending code or stored DTCs.</li> <li>• Are other DTCs present?</li> </ul>	Yes	Go to the appropriate DTC troubleshooting. (See <b><u>DTC TABLE [MZI-3.5]</u></b> .)
		No	Go to the next step.
4	<b>INSPECT FOR VISUAL CAUSES OF EXCESSIVE FUEL TANK VACUUM</b>	Yes	Remove any contamination or foreign material around fuel vapor hoses and tubes.

## 2007 Mazda CX-9 Grand Touring

2007 ENGINE PERFORMANCE On-Board Diagnostic (MZI-3.5) - CX-9

	<ul style="list-style-type: none"> <li>• Verify kinks or bends in the fuel vapor hoses and tubes.</li> <li>• Visually inspect the charcoal canister inlet port, CV solenoid valve, EVAP dust separator or the outlet hose for contamination or foreign material.</li> <li>• Is a concern evident?</li> </ul>		Repair the hoses, tubes or components if necessary. Go to Step 9.
		No	Go to the next step.
5	<b>PERFORM EVAP LEAK TEST</b> <ul style="list-style-type: none"> <li>• Connect the EVAP Leak Tester to the fuel filler pipe.</li> <li>• Close the purge solenoid valve using the EVMV PID.</li> <li>• Pressurize the EVAP system to <b>3.48 kPa</b> (PID FTP_H2O displays "14").</li> <li>• Does the pressure reach <b>3.48 kPa</b> (PID FTP_H2O displays "14")?</li> </ul>	Yes	Go to the next step.
		No	Check to see if the CV solenoid valve is stuck open. Replace if necessary. (see <b><u>CHARCOAL CANISTER, CANISTER VENT (CV) SOLENOID VALVE, AIR FILTER COMPONENT REMOVAL/INSTALLATION [MZI-3.5].</u></b> ) Go to Step 9.
6	<b>INSPECT WHETHER CV SOLENOID VALVE IS STUCK CLOSED</b> <ul style="list-style-type: none"> <li>• Open the purge solenoid valve using the EVMV PID.</li> <li>• Does the pressure drop immediately?</li> </ul>	Yes	Go to the next step.
		No	Check to see if the CV solenoid valve is stuck closed. Replace if necessary. (see <b><u>CHARCOAL CANISTER, CANISTER VENT (CV) SOLENOID VALVE, AIR FILTER COMPONENT REMOVAL/INSTALLATION [MZI-3.5].</u></b> ) Go to Step 9.
7	<b>INSPECT FOR FUEL TANK PRESSURE SENSOR PID WITHOUT PRESSURE APPLIED</b> <ul style="list-style-type: none"> <li>• Disconnect the charcoal canister outlet tube at the charcoal canister.</li> <li>• Turn the ignition switch to the ON position (Engine off).</li> <li>• Using M-MDS tester, select Diagnostic Data Link.</li> <li>• Select PCM.</li> <li>• Select Active Command Modes.</li> <li>• Access FTP V PID and record the reading.</li> <li>• Is the reading between 2.40 to</li> </ul>	Yes	Go to the next step.
		No	Replace the evaporative hose component. (see <b><u>FUEL TANK PRESSURE SENSOR INSPECTION [MZI-3.5].</u></b> ) Go to the next step.

## 2007 Mazda CX-9 Grand Touring

2007 ENGINE PERFORMANCE On-Board Diagnostic (MZI-3.5) - CX-9

	2.80 V?		
8	<b>EVAP SYSTEM LEAK TEST</b> <ul style="list-style-type: none"> <li>• Connect all disconnected connectors and hoses.</li> <li>• Perform the EVAP system leak test.</li> </ul> <p style="text-align: center;">(see <b><u>ENGINE CONTROL SYSTEM OPERATION INSPECTION [MZI-3.5]</u></b> .)</p> <ul style="list-style-type: none"> <li>• Are the test results normal?</li> </ul>	Yes	Go to the next step.
		No	Leakage still exists. Locate leak point and repair. Repeat this step.
9	<b>VERIFY TROUBLESHOOTING OF DTC P1450 HAS BEEN COMPLETED</b> <ul style="list-style-type: none"> <li>• Verify that all disconnected connectors are reconnected.</li> <li>• Turn the ignition switch to the ON position (Engine off).</li> <li>• Clear the DTC from the PCM memory using the M-MDS.</li> <li>• Start the engine and the perform "EVAP system monitor drive cycle"</li> <li>• Retrieve DTCs using the M-MDS.</li> <li>• Is the PENDING CODE for this DTC present?</li> </ul>	Yes	Replace the PCM, then go to the next step. (see <b><u>PCM REMOVAL/INSTALLATION [MZI-3.5]</u></b> .)
		No	Go to the next step.
10	<b>VERIFY AFTER REPAIR PROCEDURE</b> <ul style="list-style-type: none"> <li>• Perform "AFTER REPAIR PROCEDURE".</li> <li>• (See <b><u>AFTER REPAIR PROCEDURE [MZI-3.5]</u></b>.)</li> <li>• Are any DTC present?</li> </ul>	Yes	Go to the applicable DTC inspection. (See <b><u>DTC TABLE [MZI-3.5]</u></b> .)
		No	Troubleshooting completed.

### DTC P145E [MZI-3.5]

#### DTC P145E (MZI-3.5) DETECTION CONDITION AND POSSIBLE CAUSES

<b>DTC P145E</b>	<b>PCV heater control circuit</b>
<b>DETECTION</b>	<ul style="list-style-type: none"> <li>• This DTC sets when the PCM detects a PCV valve heater circuit</li> </ul>

## 2007 Mazda CX-9 Grand Touring

2007 ENGINE PERFORMANCE On-Board Diagnostic (MZI-3.5) - CX-9

<b>CONDITION</b>	malfunction.
<b>POSSIBLE CAUSE</b>	<ul style="list-style-type: none"><li>● Open circuit between PCV valve heater control terminal A and main relay No.1</li><li>● Open circuit between PCV valve heater fitting terminal A and main relay No.1</li><li>● Short to ground circuit between PCV valve heater control terminal B and PCM terminal 2BL</li><li>● Short to ground circuit between PCV valve heater fitting terminal B and PCM terminal 2AU</li><li>● Open circuit between PCV valve heater control terminal B and PCM terminal 2BL</li><li>● Open circuit between PCV valve heater fitting B and PCM terminal 2AU</li><li>● Connector or terminal malfunction</li><li>● PCV valve heater control malfunction</li><li>● PCV valve heater fitting malfunction</li></ul>

# 2007 Mazda CX-9 Grand Touring

2007 ENGINE PERFORMANCE On-Board Diagnostic (MZI-3.5) - CX-9

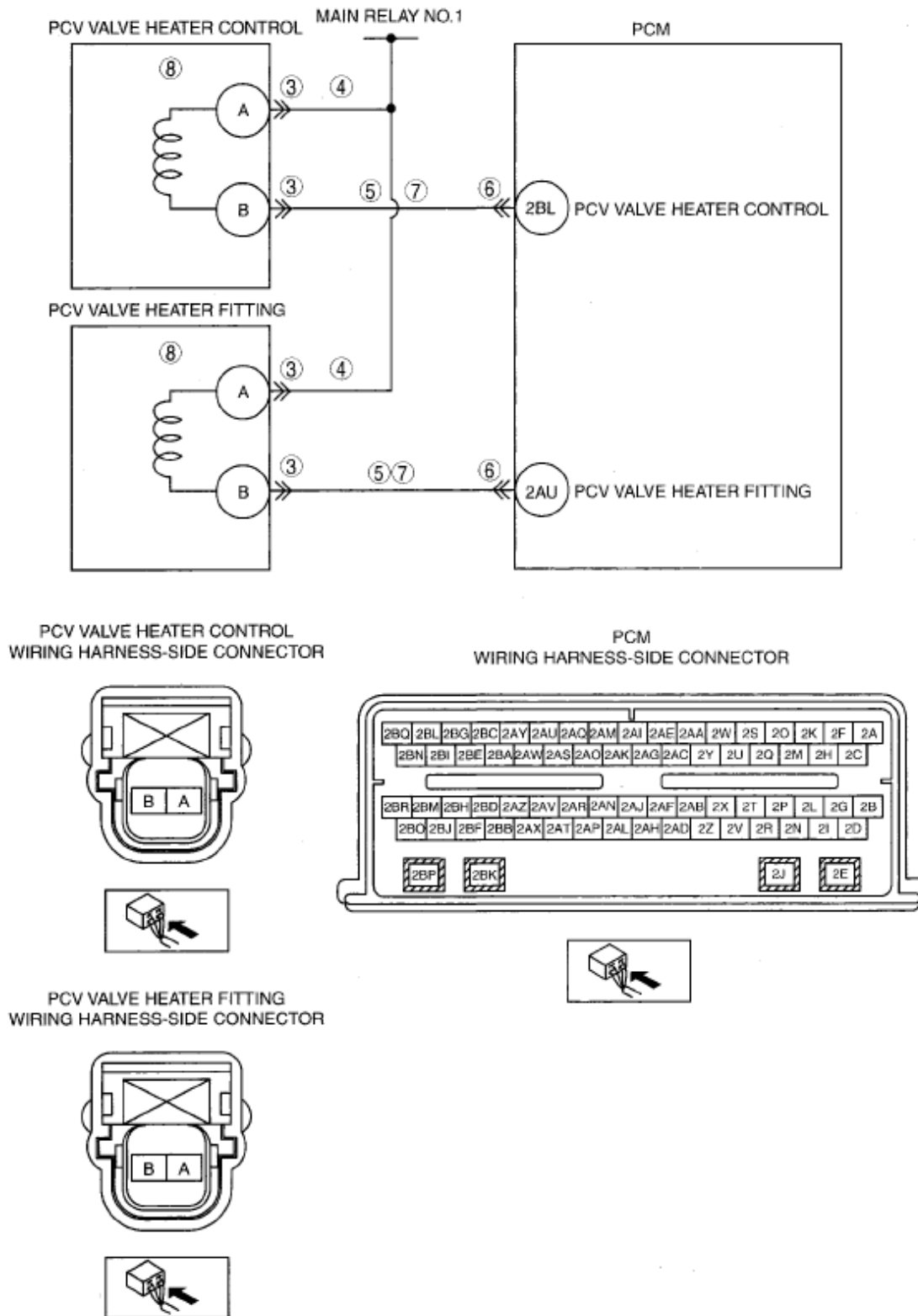

**Fig. 12: PCV Heater Control Circuit Diagram**  
 Courtesy of MAZDA MOTORS CORP.

## 2007 Mazda CX-9 Grand Touring

2007 ENGINE PERFORMANCE On-Board Diagnostic (MZI-3.5) - CX-9

### DIAGNOSTIC PROCEDURE

#### DTC P145E (MZI-3.5) DIAGNOSTIC PROCEDURE

STEP	INSPECTION	ACTION	
1	<b>VERIFY FREEZE FRAME DATA HAS BEEN RECORDED</b> <ul style="list-style-type: none"> <li>• Has FREEZE FRAME DATA been recorded?</li> </ul>	Yes	Go to the next step.
		No	Record FREEZE FRAME DATA on the repair order, then go to the next step.
2	<b>VERIFY RELATED REPAIR INFORMATION AVAILABILITY</b> <ul style="list-style-type: none"> <li>• Verify related Service Bulletins and/or on-line repair information availability.</li> <li>• Is any related Service Bulletins available?</li> </ul>	Yes	Perform repair or diagnosis according to the available Service Bulletins. <ul style="list-style-type: none"> <li>• If the vehicle is not repaired, go to the next step.</li> </ul>
		No	Go to the next step.
3	<b>INSPECT PCV VALVE HEATER CONTROL AND PCV VALVE HEATER FITTING CONNECTOR FOR POOR CONNECTION</b> <ul style="list-style-type: none"> <li>• Turn the ignition switch off.</li> <li>• Disconnect PCV valve heater control and PCV valve heater fitting connector.</li> <li>• Inspect for poor connection (such as damaged/pulled-out pins, corrosion).</li> <li>• Are there any malfunction?</li> </ul>	Yes	Repair or replace suspected part, then go to Step 9.
		No	Go to the next step.
4	<b>INSPECT POWER SUPPLY CIRCUIT FOR OPEN CIRCUIT</b> <ul style="list-style-type: none"> <li>• Turn the ignition switch to the ON position (Engine off).</li> <li>• Inspect the voltage between the following circuit:                             <ul style="list-style-type: none"> <li>○ PCV valve heater control terminal A (wiring harness-side) and body ground</li> <li>○ PCV valve heater fitting terminal A (wiring harness-side) and body ground</li> </ul> </li> <li>• Are there voltage B+?</li> </ul>	Yes	Go to the next step.
		No	Repair or replace suspected part, then go to Step 9.



## 2007 Mazda CX-9 Grand Touring

2007 ENGINE PERFORMANCE On-Board Diagnostic (MZI-3.5) - CX-9

5	<p><b>INSPECT PCV VALVE HEATER CONTROL AND PCV VALVE HEATER FITTING CIRCUIT FOR SHORT TO GROUND</b></p> <ul style="list-style-type: none"> <li>• Turn the ignition switch off.</li> <li>• Inspect for continuity between the following circuit:                             <ul style="list-style-type: none"> <li>○ PCV valve heater control terminal B (wiring harness-side) and body ground</li> <li>○ PCV valve heater fitting terminal B (wiring harness-side) and body ground</li> </ul> </li> <li>• Are there continuity?</li> </ul>	Yes	Repair or replace suspected part, then go to Step 9.
		No	Go to the next step.
6	<p><b>INSPECT PCM CONNECTOR FOR POOR CONNECTION</b></p> <ul style="list-style-type: none"> <li>• Turn the ignition switch off.</li> <li>• Disconnect PCM connector.</li> <li>• Inspect for poor connection (such as damaged/pulled-out pins, corrosion).</li> <li>• Are there any malfunction?</li> </ul>	Yes	Repair or replace suspected part, then go to Step 9.
		No	Go to the next step
7	<p><b>INSPECT PCV VALVE HEATER CONTROL AND PCV VALVE HEATER FITTING FOR OPEN CIRCUIT</b></p> <ul style="list-style-type: none"> <li>• Inspect for continuity between the following circuit:                             <ul style="list-style-type: none"> <li>○ PCV valve heater control terminal B (wiring harness-side) and PCM terminal 2BL (wiring harness-side)</li> <li>○ PCV valve heater fitting B (wiring harness-side) and PCM terminal 2AU (wiring harness-side)</li> </ul> </li> <li>• Are there continuity?</li> </ul>	Yes	Go to the next step.
		No	Repair or replace suspected part, then go to Step 9.
8	<p><b>INSPECT PCV VALVE HEATER CONTROL AND PCV VALVE HEATER FITTING</b></p>	Yes	Replace the malfunctioning part, then go to the next step.

## 2007 Mazda CX-9 Grand Touring

2007 ENGINE PERFORMANCE On-Board Diagnostic (MZI-3.5) - CX-9

	<ul style="list-style-type: none"> <li>Inspect the PCV valve heater control and PCV valve heater fitting.</li> </ul> <p>(see <b><u>POSITIVE CRANKCASE VENTILATION (PCV) VALVE INSPECTION [MZI-3.5].</u></b>)</p> <p>(see <b><u>POSITIVE CRANKCASE VENTILATION (PCV) VALVE HEATER FITTING INSPECTION [MZI-3.5].</u></b>)</p> <ul style="list-style-type: none"> <li>Is there any malfunction?</li> </ul>	No	Go to the next step.
9	<p><b>VERIFY TROUBLESHOOTING OF DTC P145E HAS BEEN COMPLETED</b></p> <ul style="list-style-type: none"> <li>Verify that all disconnected connectors reconnected.</li> <li>Clear the DTC from the PCM memory using the M-MDS.</li> <li>Perform the "KOEO or KOER self-test" using the M-MDS.</li> </ul> <p>(See <b><u>KOEO/KOER SELF TEST [MZI-3.5].</u></b>)</p> <ul style="list-style-type: none"> <li>Is the PENDING CODE for the DTC present?</li> </ul>	Yes	Replace the PCM, then go to the next step. (see <b><u>PCM REMOVAL/INSTALLATION [MZI-3.5].</u></b> )
		No	Go to the next step.
10	<p><b>VERIFY AFTER REPAIR PROCEDURE</b></p> <ul style="list-style-type: none"> <li>Perform the "AFTER REPAIR PROCEDURE".</li> </ul> <p>(See <b><u>AFTER REPAIR PROCEDURE [MZI-3.5].</u></b>)</p> <ul style="list-style-type: none"> <li>Are any DTCs present?</li> </ul>	Yes	Go to the applicable DTC inspection. (See <b><u>DTC TABLE [MZI-3.5].</u></b> )
		No	Troubleshooting completed.

### DTC P1464 [MZI-3.5]

#### DTC P1464 (MZI-3.5) DETECTION CONDITION AND POSSIBLE CAUSES

DTC P1464	A/C demand out of self-test range
-----------	-----------------------------------

## 2007 Mazda CX-9 Grand Touring

2007 ENGINE PERFORMANCE On-Board Diagnostic (MZI-3.5) - CX-9

<b>DETECTION CONDITION</b>	<ul style="list-style-type: none"> <li>The DTC sets when the PCM receives a request for A/C during the self-test.</li> </ul>
<b>POSSIBLE CAUSE</b>	<ul style="list-style-type: none"> <li>A/C or defrost on during self-test</li> <li>A/C relay circuit short to voltage</li> <li>A/C switch malfunction</li> <li>A/C relay malfunction</li> </ul>

### DIAGNOSTIC PROCEDURE

#### DTC P1464 (MZI-3.5) DIAGNOSTIC PROCEDURE

STEP	INSPECTION		ACTION
1	<b>VERIFY FREEZE FRAME DATA HAS BEEN RECORDED</b> <ul style="list-style-type: none"> <li>Has FREEZE FRAME DATA been recorded?</li> </ul>	Yes	Go to the next step.
		No	Record FREEZE FRAME DATA on the repair order, then go to the next step.
2	<b>VERIFY RELATED REPAIR INFORMATION AVAILABILITY</b> <ul style="list-style-type: none"> <li>Verify related Service Bulletins and/or on-line repair information availability.</li> <li>Is any related Service Bulletins available?</li> </ul>	Yes	Perform repair or diagnosis according to the available Service Bulletins. <ul style="list-style-type: none"> <li>If the vehicle is not repaired, go to the next step.</li> </ul>
		No	Go to the next step.
3	<b>VERIFY A/C AND DEFROST ARE OFF DURING SELF-TEST</b> <ul style="list-style-type: none"> <li>Perform the "KOEO/KOER self-test".</li> </ul> (See <b><u>KOEO/KOER SELF TEST [MZI-3.5].</u></b> ) <ul style="list-style-type: none"> <li>Are the A/C and defrost off during the self-test?</li> </ul>	Yes	Go to the next step.
		No	Turn the A/C and defrost off. Then go to Step 5.
4	<b>INSPECT ACCS PID</b> <ul style="list-style-type: none"> <li>Turn the ignition switch to the ON position (Engine off).</li> <li>A/C and defroster OFF.</li> <li>Access the PCM and monitor the ACCS PID.</li> <li>Is the PID state ON?</li> </ul>	Yes	The ACCS PID indicates that the PCM is being requested to turn on the A/C. Inspect the A/C system. (see <b><u>DIAGNOSTIC TROUBLE CODE NUMBER INSPECTION .</u></b> ) Then go to the next step.
		No	The ACCS PID indicates that the ACCS input to the PCM is low. Go to the next step.

## 2007 Mazda CX-9 Grand Touring

2007 ENGINE PERFORMANCE On-Board Diagnostic (MZI-3.5) - CX-9

5	<b>VERIFY TROUBLESHOOTING OF DTC P1464 HAS BEEN COMPLETED</b> <ul style="list-style-type: none"> <li>• Verify that all disconnected connectors reconnected.</li> <li>• Clear the DTC from the PCM memory using the M-MDS.</li> <li>• Perform the KOEO or KOER self-test using the M-MDS.</li> </ul> <p>(See <b>KOEO/KOER SELF TEST [MZI-3.5].</b>)</p> <ul style="list-style-type: none"> <li>• Is the PENDING CODE for the DTC present?</li> </ul>	Yes	Replace the PCM, then go to the next step. (see <b>PCM REMOVAL/INSTALLATION [MZI-3.5]</b> .)
		No	Go to the next step.
6	<b>VERIFY AFTER REPAIR PROCEDURE</b> <ul style="list-style-type: none"> <li>• Perform "AFTER REPAIR PROCEDURE".</li> </ul> <p>(See <b>AFTER REPAIR PROCEDURE [MZI-3.5].</b>)</p> <ul style="list-style-type: none"> <li>• Are any DTCs present?</li> </ul>	Yes	Go to the applicable DTC inspection. (See <b>DTC TABLE [MZI-3.5].</b> )
		No	Troubleshooting completed.

### DTC P1500 [MZI-3.5]

#### DTC P1500 (MZI-3.5) DETECTION CONDITION AND POSSIBLE CAUSES

<b>DTC P1500</b>	<b>Vehicle speed signal</b>
<b>DETECTION CONDITION</b>	<ul style="list-style-type: none"> <li>• Indicates the VSS input signal was intermittent. This DTC is set when a VSS concern interferes with other OBD tests, such as the catalyst efficiency monitor, the EVAP monitor, or the HO2S monitor.</li> </ul>
<b>POSSIBLE CAUSE</b>	<ul style="list-style-type: none"> <li>• Intermittent sensor connections</li> <li>• Intermittent open in the sensor wiring harness circuit(s)</li> <li>• Intermittent short in the sensor wiring harness circuit(s)</li> <li>• Sensor malfunction</li> </ul>

#### DIAGNOSTIC PROCEDURE

#### DTC P1500 (MZI-3.5) DIAGNOSTIC PROCEDURE

STEP	INSPECTION	ACTION

## 2007 Mazda CX-9 Grand Touring

2007 ENGINE PERFORMANCE On-Board Diagnostic (MZI-3.5) - CX-9

1	<b>VERIFY FREEZE FRAME DATA HAS BEEN RECORDED</b> <ul style="list-style-type: none"> <li>• Has FREEZE FRAME DATA been recorded?</li> </ul>	Yes	Go to the next step.
		No	Record FREEZE FRAME DATA on the repair order, then go to the next step.
2	<b>VERIFY RELATED REPAIR INFORMATION AVAILABILITY</b> <ul style="list-style-type: none"> <li>• Verify related Service Bulletins and/or on-line repair information availability.</li> <li>• Is any related Service Bulletins available?</li> </ul>	Yes	Perform repair or diagnosis according to the available Service Bulletins. <ul style="list-style-type: none"> <li>• If the vehicle is not repaired, go to the next step.</li> </ul>
		No	Go to the next step.
3	<b>VERIFY STORED DTC IN DSC/RSC HU/CM</b> <ul style="list-style-type: none"> <li>• Turn the ignition switch to the ON position (Engine off).</li> <li>• Verify stored DTCs in DSC/RSC HU/CM.</li> <li>• Are DTCs stored?</li> </ul>	Yes	Go to the appropriate DTC inspection. (see <b><u>ON-BOARD DIAGNOSIS [DSC/RSC]</u></b> .)
		No	Go to the next step.
4	<b>VERIFY TROUBLESHOOTING OF DTC P1500 HAS BEE COMPLETED</b> <ul style="list-style-type: none"> <li>• Verify that all disconnected connectors reconnected.</li> <li>• Clear the DTC from the PCM memory using the M-MDS.</li> <li>• Perform the "KOEO or KOER self-test" using the M-MDS.</li> </ul> <p>(See <b><u>KOEO/KOER SELF TEST [MZI-3.5]</u></b> )</p> <ul style="list-style-type: none"> <li>• Is the PENDING CODE for the DTC present?</li> </ul>	Yes	Replace the PCM, then go to the next step. (see <b><u>PCM REMOVAL/INSTALLATION [MZI-3.5]</u></b> .)
		No	Go to the next step.
5	<b>VERIFY AFTER REPAIR PROCEDURE</b> <ul style="list-style-type: none"> <li>• Perform the "AFTER REPAIR PROCEDURE".</li> </ul> <p>(See <b><u>AFTER REPAIR PROCEDURE [MZI-3.5]</u></b>.)</p>	Yes	Go to the applicable DTC inspection. (See <b><u>DTC TABLE [MZI-3.5]</u></b> .)
		No	Troubleshooting completed.

## 2007 Mazda CX-9 Grand Touring

2007 ENGINE PERFORMANCE On-Board Diagnostic (MZI-3.5) - CX-9

- |   |  |
|---|--|
| <ul style="list-style-type: none"> <li>• Are any DTCs present?</li> </ul> |  |
|---|--|

### DTC P1501 [MZI-3.5]

#### DTC P1501 (MZI-3.5) DETECTION CONDITION AND POSSIBLE CAUSES

DTC P1501	Vehicle speed sensor (VSS) out of self-test range
<b>DETECTION CONDITION</b>	<ul style="list-style-type: none"> <li>• Indicates that the vehicle speed input signal is out of the self-test range. If the PCM detects a vehicle speed input signal any time during the self-test, DTC P1501 is set and the test aborts.</li> </ul>
<b>POSSIBLE CAUSE</b>	<ul style="list-style-type: none"> <li>• Noise on the vehicle speed input signal from radio frequency interference/electro magnetic interference</li> <li>• External sources, such as ignition wires, the charging circuit, or aftermarket equipment</li> </ul>

#### DIAGNOSTIC PROCEDURE

#### DTC P1501 (MZI-3.5) DIAGNOSTIC PROCEDURE

STEP	INSPECTION		ACTION
1	<b>VERIFY FREEZE FRAME DATA HAS BEEN RECORDED</b> <ul style="list-style-type: none"> <li>• Has FREEZE FRAME DATA been recorded?</li> </ul>	Yes	Go to the next step.
		No	Record FREEZE FRAME DATA on the repair order, then go to the next step.
2	<b>VERIFY RELATED REPAIR INFORMATION AVAILABILITY</b> <ul style="list-style-type: none"> <li>• Verify related Service Bulletins and/or on-line repair information availability.</li> <li>• Is any related Service Bulletins available?</li> </ul>	Yes	Perform repair or diagnosis according to the available Service Bulletins. <ul style="list-style-type: none"> <li>• If the vehicle is not repaired, go to the next step.</li> </ul>
		No	Go to the next step.
3	<b>VERIFY STORED DTC IN DSC/RSC HU/CM</b> <ul style="list-style-type: none"> <li>• Turn the ignition switch to the ON position (Engine off).</li> <li>• Verify stored DTCs in DSC/RSC HU/CM.</li> <li>• Are DTCs stored?</li> </ul>	Yes	Go to the appropriate DTC inspection. (see <b><u>ON-BOARD DIAGNOSIS [DSC/RSC]</u></b> .)
		No	Go to the next step.
4	<b>VERIFY TROUBLESHOOTING OF DTC P1501 HAS BEEN COMPLETED</b>	Yes	Replace the PCM, then go to the next step. (see <b><u>PCM REMOVAL/INSTALLATION [MZI-3.5]</u></b> .)

## 2007 Mazda CX-9 Grand Touring

2007 ENGINE PERFORMANCE On-Board Diagnostic (MZI-3.5) - CX-9

	<ul style="list-style-type: none"> <li>Verify that all disconnected connectors reconnected.</li> <li>Clear the DTC from the PCM memory using the M-MDS.</li> <li>Perform the "KOEO or KOER self-test" using the M-MDS.</li> </ul> <p>(See <b><u>KOEO/KOER SELF TEST [MZI-3.5].</u></b>)</p> <ul style="list-style-type: none"> <li>Is the PENDING CODE for the DTC present?</li> </ul>	No	Go to the next step.
5	<p><b>VERIFY AFTER REPAIR PROCEDURE</b></p> <ul style="list-style-type: none"> <li>Perform the "AFTER REPAIR PROCEDURE".</li> </ul> <p>(See <b><u>AFTER REPAIR PROCEDURE [MZI-3.5].</u></b>)</p> <ul style="list-style-type: none"> <li>Are any DTCs present?</li> </ul>	Yes	Go to the applicable DTC inspection. (See <b><u>DTC TABLE [MZI-3.5].</u></b> )
		No	Troubleshooting completed.

### DTC P1633 [MZI-3.5]

#### DTC P1633 (MZI-3.5) DETECTION CONDITION AND POSSIBLE CAUSES

<b>DTC P1633</b>	<b>Keep alive power voltage too low</b>
<b>DETECTION CONDITION</b>	<ul style="list-style-type: none"> <li>Indicates the keep alive power circuit has experienced a voltage interrupt.</li> </ul>
<b>POSSIBLE CAUSE</b>	<ul style="list-style-type: none"> <li>Connector or terminal malfunction</li> <li>Open circuit between battery positive terminal and PCM terminal 1 BB</li> </ul>

## 2007 Mazda CX-9 Grand Touring

2007 ENGINE PERFORMANCE On-Board Diagnostic (MZI-3.5) - CX-9

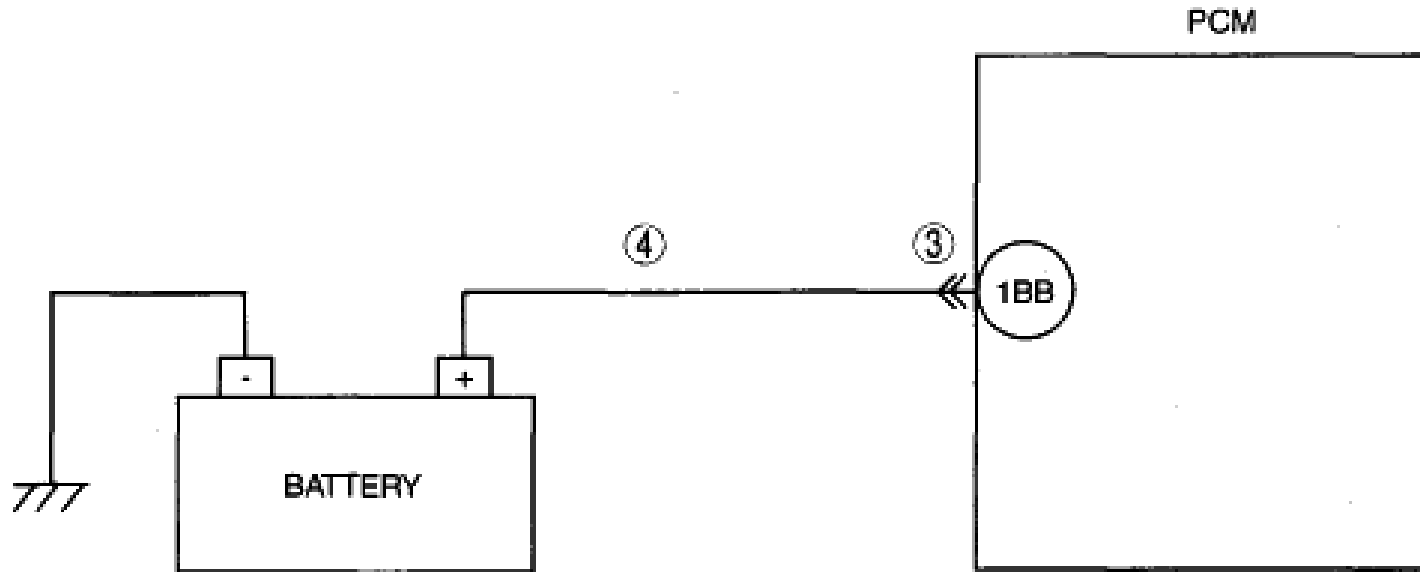

PCM  
WIRING HARNESS-SIDE CONNECTOR

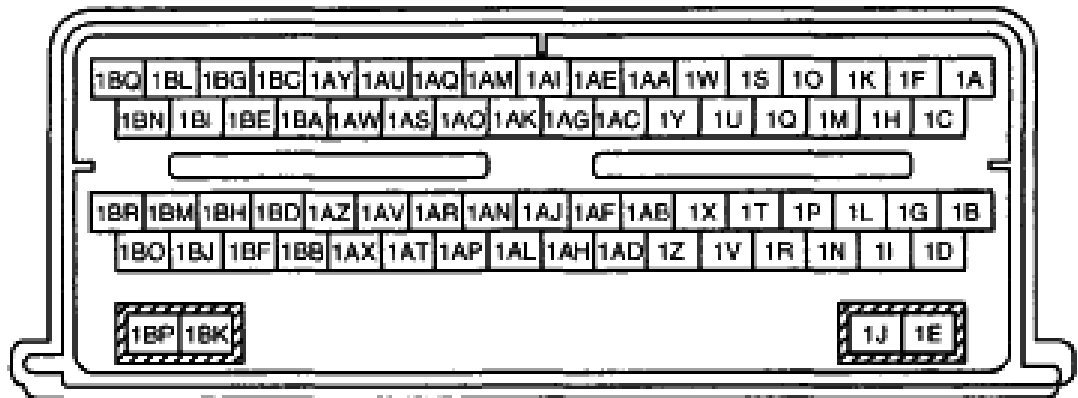

### DIAGNOSTIC PROCEDURE

#### DTC P1633 (MZI-3.5) DIAGNOSTIC PROCEDURE

STEP	INSPECTION		ACTION
1	VERIFY FREEZE FRAME DATA HAS BEEN RECORDED	Yes	Go to the next step.



## 2007 Mazda CX-9 Grand Touring

2007 ENGINE PERFORMANCE On-Board Diagnostic (MZI-3.5) - CX-9

	<ul style="list-style-type: none"> <li>• Has FREEZE FRAME DATA been recorded?</li> </ul>	No	Record FREEZE FRAME DATA on the repair order, then go to the next step.
2	<b>VERIFY RELATED REPAIR INFORMATION AVAILABILITY</b> <ul style="list-style-type: none"> <li>• Verify related Service Bulletins and/or on-line repair information availability.</li> <li>• Is any related Service Bulletins available?</li> </ul>	Yes	Perform repair or diagnosis according to the available Service Bulletins. <ul style="list-style-type: none"> <li>• If the vehicle is not repaired, go to the next step.</li> </ul>
		No	Go to the next step.
3	<b>INSPECT BATTERY TERMINAL AND PCM CONNECTOR FOR POOR CONNECTION</b> <ul style="list-style-type: none"> <li>• Turn the ignition switch off.</li> <li>• Disconnect battery terminal and PCM connector.</li> <li>• Inspect for poor connection (such as damaged/pulled-out pins, corrosion).</li> <li>• Is there any malfunction?</li> </ul>	Yes	Repair or replace suspected part, then go to Step 5.
		No	Go to the next step.
4	<b>INSPECT KEEP ALIVE POWER CIRCUIT FOR OPEN CIRCUIT</b> <ul style="list-style-type: none"> <li>• Turn the ignition switch off.</li> <li>• Disconnect battery cables.</li> <li>• Disconnect PCM connector.</li> <li>• Check continuity between battery positive terminal (harness-side) and PCM terminal 1BB (wiring harness-side).</li> <li>• Is there continuity?</li> </ul>	Yes	Go to the next step.
		No	Repair or replace suspected part, then go to the next step.
5	<b>VERIFY TROUBLESHOOTING OF DTC P1633 HAS BEEN COMPLETED</b> <ul style="list-style-type: none"> <li>• Make sure to reconnect all disconnected connectors.</li> <li>• Clear the DTC from the PCM memory using the M-MDS.</li> <li>• Start the engine.</li> <li>• Is the same DTC present?</li> </ul>	Yes	Replace the PCM, then go to the next step. (see <b><u>PCM REMOVAL/INSTALLATION [MZI-3.5]</u></b> .)
		No	Go to the next step.
6	<b>VERIFY AFTER REPAIR</b>	Yes	Go to the applicable DTC inspection.

## 2007 Mazda CX-9 Grand Touring

2007 ENGINE PERFORMANCE On-Board Diagnostic (MZI-3.5) - CX-9

<p><b>PROCEDURE</b></p> <ul style="list-style-type: none"> <li>Perform the "AFTER REPAIR PROCEDURE".</li> </ul> <p>(See <b><u>AFTER REPAIR PROCEDURE [MZI-3.5].</u></b>)</p> <ul style="list-style-type: none"> <li>Are any DTCs present?</li> </ul>		(See <b><u>DTC TABLE [MZI-3.5].</u></b> )
	No	Troubleshooting completed.

### DTC P1635 [MZI-3.5]

#### DTC P1635 (MZI-3.5) DETECTION CONDITION AND POSSIBLE CAUSES

<b>DTC P1635</b>	<b>Tire/axle out of acceptable range</b>
<b>DETECTION CONDITION</b>	<ul style="list-style-type: none"> <li>This DTC indicates the tire and axle information contained in the vehicle identification block does not match the vehicle hardware.</li> </ul>
<b>POSSIBLE CAUSE</b>	<ul style="list-style-type: none"> <li>Incorrect tire size</li> <li>Incorrect axle ratio</li> <li>Incorrect vehicle identification configuration parameters</li> </ul>

#### DIAGNOSTIC PROCEDURE

#### DTC P1635 (MZI-3.5) DIAGNOSTIC PROCEDURE

STEP	INSPECTION		ACTION
1	<b>VERIFY FREEZE FRAME DATA HAS BEEN RECORDED</b> <ul style="list-style-type: none"> <li>Has FREEZE FRAME DATA been recorded?</li> </ul>	Yes	Go to the next step.
		No	Record FREEZE FRAME DATA on the repair order, then go to the next step.
2	<b>VERIFY RELATED REPAIR INFORMATION AVAILABILITY</b> <ul style="list-style-type: none"> <li>Verify related Service Bulletins and/or on-line repair information availability.</li> <li>Is any related Service Bulletins available?</li> </ul>	Yes	Perform repair or diagnosis according to available Service Bulletins. <ul style="list-style-type: none"> <li>If vehicle is not repaired, go to the next step.</li> </ul>
		No	Go to the next step.
3	<b>VERIFY VEHICLE IDENTIFICATION TIRE DATA</b> <ul style="list-style-type: none"> <li>Turn the ignition switch to the ON position.</li> <li>Connect the M-MDS to the DLC-</li> </ul>	Yes	Go to the next step.
		No	Perform PCM configuration procedure, then go to Step 5. (see <b><u>PCM CONFIGURATION [MZI-3.5]</u></b> .)

## 2007 Mazda CX-9 Grand Touring

2007 ENGINE PERFORMANCE On-Board Diagnostic (MZI-3.5) - CX-9

	<p>2.</p> <ul style="list-style-type: none"> <li>• Access the data of the tire size.</li> <li>• Is it the same as a equipped tire?</li> </ul>		
4	<p><b>VERIFY GENUINE TIRES ARE INSTALLED</b></p> <ul style="list-style-type: none"> <li>• Is genuine tires are equipped?</li> </ul>	Yes	Go to the next step.
		No	Change to the genuine tire, then go to the next step.
5	<p><b>VERIFY TROUBLESHOOTING OF DTC P1635 HAS BEEN COMPLETED</b></p> <ul style="list-style-type: none"> <li>• Verify that all disconnected connectors reconnected.</li> <li>• Turn the ignition switch to the ON position (Engine off).</li> <li>• Clear DTC from PCM memory using M-MDS.</li> <li>• Start engine and warm up it completely.</li> <li>• Is same DTC present?</li> </ul>	Yes	Replace the PCM, then go to the next step. (see <b><u>PCM REMOVAL/INSTALLATION [MZI-3.5]</u></b> .)
		No	Go to the next step.
6	<p><b>VERIFY AFTER REPAIR PROCEDURE</b></p> <ul style="list-style-type: none"> <li>• Perform "AFTER REPAIR PRECAUTION".</li> </ul> <p>(See <b><u>AFTER REPAIR PROCEDURE [MZI-3.5]</u></b>.)</p> <ul style="list-style-type: none"> <li>• Are any DTCs present?</li> </ul>	Yes	Go to the applicable DTC inspection. (See <b><u>DTC TABLE [MZI-3.5]</u></b> .)
		No	Troubleshooting completed.

### DTC P1639 [MZI-3.5]

#### DTC P1639 (MZI-3.5) DETECTION CONDITION AND POSSIBLE CAUSES

<b>DTC P1639</b>	<b>Vehicle ID block corrupted, that not programmed</b>
<b>DETECTION CONDITION</b>	<ul style="list-style-type: none"> <li>• This DTC indicates that the VID block is not programmed or the information within is corrupt.</li> </ul>
<b>POSSIBLE CAUSE</b>	<ul style="list-style-type: none"> <li>• New PCM</li> <li>• Incorrect PCM</li> <li>• Incorrect VID configuration</li> </ul>

#### DIAGNOSTIC PROCEDURE

## 2007 Mazda CX-9 Grand Touring

2007 ENGINE PERFORMANCE On-Board Diagnostic (MZI-3.5) - CX-9

### DTC P1639 (MZI-3.5) DIAGNOSTIC PROCEDURE

STEP	INSPECTION	ACTION	
1	<b>VERIFY FREEZE FRAME DATA HAS BEEN RECORDED</b> <ul style="list-style-type: none"> <li>• Has FREEZE FRAME DATA been recorded?</li> </ul>	Yes	Go to the next step.
		No	Record FREEZE FRAME DATA on the repair order, then go to the next step.
2	<b>VERIFY RELATED REPAIR INFORMATION AVAILABILITY</b> <ul style="list-style-type: none"> <li>• Verify related Service Bulletins and/or on-line repair information availability.</li> <li>• Is any related Service Bulletins available?</li> </ul>	Yes	Perform repair or diagnosis according to the available Service Bulletins. <ul style="list-style-type: none"> <li>• If the vehicle is not repaired, go to the next step.</li> </ul>
		No	Perform the PCM reprogramming procedure. (see <b><u>PCM CONFIGURATION [MZI-3.5]</u></b> .) Then go to the next step.
3	<b>VERIFY TROUBLESHOOTING OF DTC P1639 HAS BEEN COMPLETED</b> <ul style="list-style-type: none"> <li>• Verify that all disconnected connectors are reconnected.</li> <li>• Turn the ignition switch to the ON position (Engine off).</li> <li>• Clear the DTC from the PCM memory using the M-MDS.</li> <li>• Start the engine and perform the KOEO and KOER self-test.</li> <li>• Retrieve DTCs using the M-MDS.</li> <li>• Is the PENDING CODE for this DTC present?</li> </ul>	Yes	Replace the PCM, then go to the next step. (see <b><u>PCM REMOVAL/INSTALLATION [MZI-3.5]</u></b> .)
		No	Go to the next step.
4	<b>VERIFY AFTER REPAIR PROCEDURE</b> <ul style="list-style-type: none"> <li>• Perform the "AFTER REPAIR PROCEDURE".</li> </ul> (See <b><u>AFTER REPAIR PROCEDURE [MZI-3.5]</u></b> .) <ul style="list-style-type: none"> <li>• Are any DTC present?</li> </ul>	Yes	Go to the applicable DTC inspection. (See <b><u>DTC TABLE [MZI-3.5]</u></b> .)
		No	Troubleshooting completed.

### DTC P1650 [MZI-3.5]

## 2007 Mazda CX-9 Grand Touring

2007 ENGINE PERFORMANCE On-Board Diagnostic (MZI-3.5) - CX-9

### DTC P1650 (MZI-3.5) DETECTION CONDITION AND POSSIBLE CAUSES

<b>DTC P1650</b>	<b>PSP switch out of self-test range</b>
<b>DETECTION CONDITION</b>	<ul style="list-style-type: none"> <li>In the KOEO self-test, this DTC indicates the PSP input to the PCM is high.</li> <li>In the KOER self-test, this DTC indicates the PSP input did not change state.</li> </ul>
<b>POSSIBLE CAUSE</b>	<ul style="list-style-type: none"> <li>The steering wheel must be turned during KOER self-test</li> <li>PSP switch malfunction</li> <li>Open circuit between PSP switch terminal A and PCM terminal 2I</li> <li>Short to ground circuit between PSP switch terminal A and PCM terminal 2I</li> </ul>

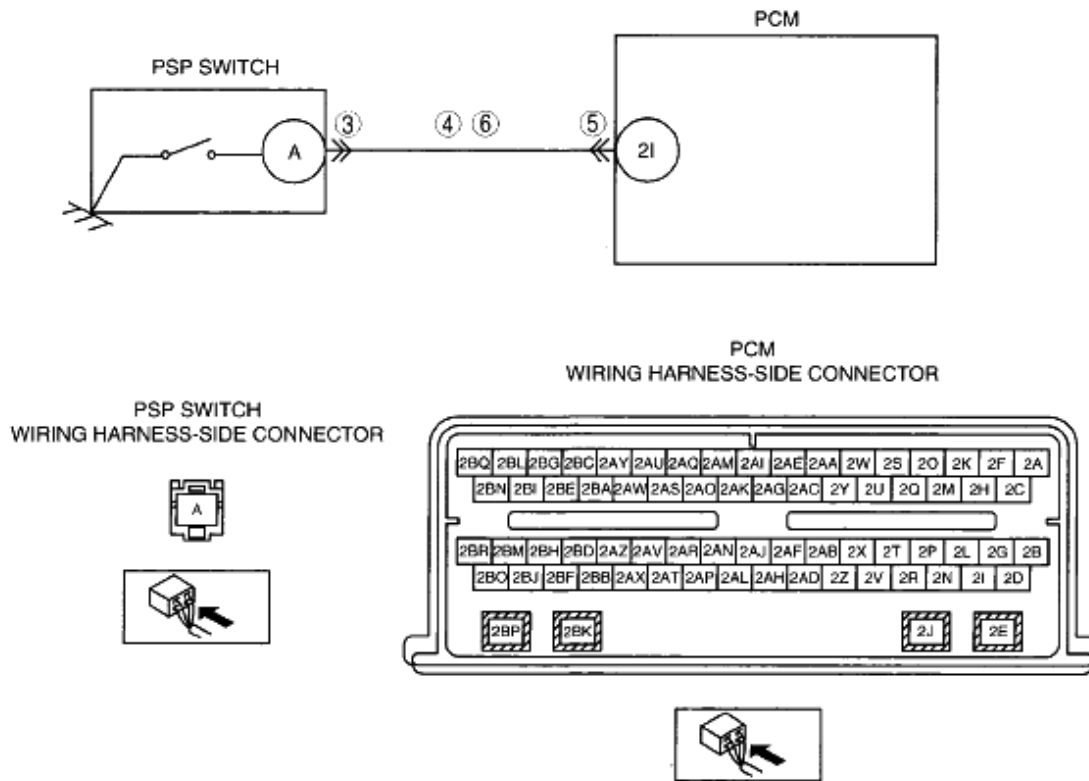

**Fig. 13: PSP Switch Circuit Diagram**  
 Courtesy of MAZDA MOTORS CORP.

### DIAGNOSTIC PROCEDURE

#### DTC P1650 (MZI-3.5) DIAGNOSTIC PROCEDURE

STEP	INSPECTION		ACTION
1	<b>VERIFY FREEZE FRAME DATA HAS BEEN RECORDED</b>	Yes	Go to the next step.
		No	Record FREEZE FRAME DATA on the repair order, then go to the next step.
	<ul style="list-style-type: none"> <li>Has FREEZE FRAME DATA been recorded?</li> </ul>		

## 2007 Mazda CX-9 Grand Touring

2007 ENGINE PERFORMANCE On-Board Diagnostic (MZI-3.5) - CX-9

2	<b>VERIFY RELATED REPAIR INFORMATION AVAILABILITY</b> <ul style="list-style-type: none"> <li>• Verify related Service Bulletins and/or on-line repair information availability.</li> <li>• Is any related Service Bulletins available?</li> </ul>	Yes	Perform repair or diagnosis according to available Service Bulletins. <ul style="list-style-type: none"> <li>• If vehicle is not repaired, go to next step.</li> </ul>
		No	Go to the next step.
3	<b>INSPECT PSP SWITCH CONNECTOR FOR POOR CONNECTION</b> <ul style="list-style-type: none"> <li>• Turn the ignition switch off.</li> <li>• Disconnect the PCM connector.</li> <li>• Inspect for poor connection (such as damaged/pulled-out pins, corrosion).</li> <li>• Is there any malfunction?</li> </ul>	Yes	Repair or replace suspected part, then go to Step 8.
		No	Go to the next step.
4	<b>INSPECT PSP SWITCH CIRCUIT FOR SHORT TO GROUND</b> <ul style="list-style-type: none"> <li>• Turn the ignition switch off.</li> <li>• Inspect for continuity between PSP switch terminal A (wiring harness-side) and body ground.</li> <li>• Is there continuity?</li> </ul>	Yes	Repair or replace suspected part, then go to Step 8.
		No	Go to the next step.
5	<b>INSPECT PCM CONNECTOR FOR POOR CONNECTION</b> <ul style="list-style-type: none"> <li>• Turn the ignition switch off.</li> <li>• Disconnect the PCM connector.</li> <li>• Inspect for poor connection (such as damaged/pulled-out pins, corrosion).</li> <li>• Is there any malfunction?</li> </ul>	Yes	Repair or replace suspected part, then go to Step 8.
		No	Go to the next step.
6	<b>INSPECT PSP SWITCH CIRCUIT FOR OPEN CIRCUIT</b> <ul style="list-style-type: none"> <li>• Inspect for continuity between PSP switch terminal A (wiring harness-side) and PCM terminal 2I (wiring harness-side)</li> <li>• Is there continuity?</li> </ul>	Yes	Go to the next step.
		No	Repair or replace suspected part, then go to Step 8.

## 2007 Mazda CX-9 Grand Touring

2007 ENGINE PERFORMANCE On-Board Diagnostic (MZI-3.5) - CX-9

7	<p><b>INSPECT FOR CORRECT PCM OPERATION</b></p> <ul style="list-style-type: none"> <li>• Disconnect all the PCM connectors.</li> <li>• Visually inspect for:                             <ul style="list-style-type: none"> <li>○ Pushed out pins</li> <li>○ Corrosion</li> </ul> </li> <li>• Connect all the PCM connectors and verify that they seat correctly.</li> <li>• Retrieve DTCs using the M-MDS.</li> <li>• Is the PENDING CODE for this DTC present?</li> </ul>	Yes	Go to the next step.
		No	The system is correctly. Go to the next step.
8	<p><b>VERIFY TROUBLESHOOTING OF DTC P1650 HAS BEEN COMPLETED</b></p> <ul style="list-style-type: none"> <li>• Verify that all disconnected connectors reconnected.</li> <li>• Start the engine.</li> <li>• Clear DTC from PCM memory using M-MDS.</li> <li>• Perform the "KOEO/KOER Self-Test".</li> </ul> <p>(See <b><u>KOEO/KOER SELF TEST [MZI-3.5].</u></b>)</p> <ul style="list-style-type: none"> <li>• Is same DTC present?</li> </ul>	Yes	Replace the PCM, then go to the next step. (see <b><u>PCM REMOVAL/INSTALLATION [MZI-3.5].</u></b> )
		No	Go to the next step.
9	<p><b>VERIFY AFTER REPAIR PROCEDURE</b></p> <ul style="list-style-type: none"> <li>• Perform "AFTER REPAIR PROCEDURE".</li> </ul> <p>(See <b><u>AFTER REPAIR PROCEDURE [MZI-3.5].</u></b>)</p> <ul style="list-style-type: none"> <li>• Are any DTCs present?</li> </ul>	Yes	Go to the applicable DTC inspection. (See <b><u>DTC TABLE [MZI-3.5].</u></b> )
		No	Troubleshooting completed.

### DTC P1674 [MZI-3.5]

#### DTC P1674 (MZI-3.5) DETECTION CONDITION AND POSSIBLE CAUSES

--	--

## 2007 Mazda CX-9 Grand Touring

2007 ENGINE PERFORMANCE On-Board Diagnostic (MZI-3.5) - CX-9

<b>DTC P1674</b>	<b>Control module software corrupted</b>
<b>DETECTION CONDITION</b>	<ul style="list-style-type: none"> <li>Indicates that an error occurred in the PCM. This DTC is set in combination with P2105.</li> </ul>
<b>POSSIBLE CAUSE</b>	<ul style="list-style-type: none"> <li>Software incompatibility issue</li> <li>PCM malfunction</li> </ul>

### DIAGNOSTIC PROCEDURE

#### DTC P1674 (MZI-3.5) DIAGNOSTIC PROCEDURE

STEP	INSPECTION	ACTION	
1	<b>VERIFY FREEZE FRAME DATA HAS BEEN RECORDED</b> <ul style="list-style-type: none"> <li>Has FREEZE FRAME DATA been recorded?</li> </ul>	Yes	Go to the next step.
		No	Record FREEZE FRAME DATA on the repair order, then go to the next step.
2	<b>VERIFY RELATED REPAIR INFORMATION AVAILABILITY</b> <ul style="list-style-type: none"> <li>Verify related Service Bulletins and/or on-line repair information availability.</li> <li>Is any related Service Bulletins available?</li> </ul>	Yes	Perform repair or diagnosis according to the available Service Bulletins. <ul style="list-style-type: none"> <li>If the vehicle is not repaired, go to the next step.</li> </ul>
		No	Perform the PCM reprogramming procedure. (see <b>PCM CONFIGURATION [MZI-3.5]</b> .) Then go to the next step.
3	<b>VERIFY TROUBLESHOOTING OF DTC P1674 HAS BEEN COMPLETED</b> <ul style="list-style-type: none"> <li>Verify that all disconnected connectors are reconnected.</li> <li>Turn the ignition switch to the ON position (Engine off).</li> <li>Clear the DTC from the PCM memory using the M-MDS.</li> <li>Start the engine and perform the KOEO and KOER self-test.</li> <li>Retrieve DTCs using the M-MDS.</li> <li>Is the PENDING CODE for this DTC present?</li> </ul>	Yes	Replace the PCM, then go to the next step. (see <b>PCM REMOVAL/INSTALLATION [MZI-3.5]</b> .)
		No	Go to the next step.
4	<b>VERIFY AFTER REPAIR PROCEDURE</b> <ul style="list-style-type: none"> <li>Perform the "AFTER REPAIR</li> </ul>	Yes	Go to the applicable DTC inspection. (See <b>DTC TABLE [MZI-3.5]</b> .)



## 2007 Mazda CX-9 Grand Touring

2007 ENGINE PERFORMANCE On-Board Diagnostic (MZI-3.5) - CX-9

	PROCEDURE".  (see <b><u>KOEO/KOER SELF TEST [MZI-3.5].</u></b> )  • Are any DTC present?	No	Troubleshooting completed.
--	--	----	----------------------------

### DTC P1703 [MZI-3.5]

#### DTC P1703 (MZI-3.5) DETECTION CONDITION AND POSSIBLE CAUSES

<b>DTC P1703</b>	<b>Brake switch out of self-test range</b>
<b>DETECTION CONDITION</b>	<ul style="list-style-type: none"><li>• Indicates that during the KOEO self-test, the brake pedal position signal was high. during the KOER self-test, the BPP signal did not cycle high and low.</li></ul>
<b>POSSIBLE CAUSE</b>	<ul style="list-style-type: none"><li>• Connector or terminal malfunction</li><li>• Brake switch No.1 malfunction</li><li>• Brake switch No.1 mis installation</li><li>• Brake switch No.1 circuit malfunction</li></ul>

## 2007 Mazda CX-9 Grand Touring

2007 ENGINE PERFORMANCE On-Board Diagnostic (MZI-3.5) - CX-9

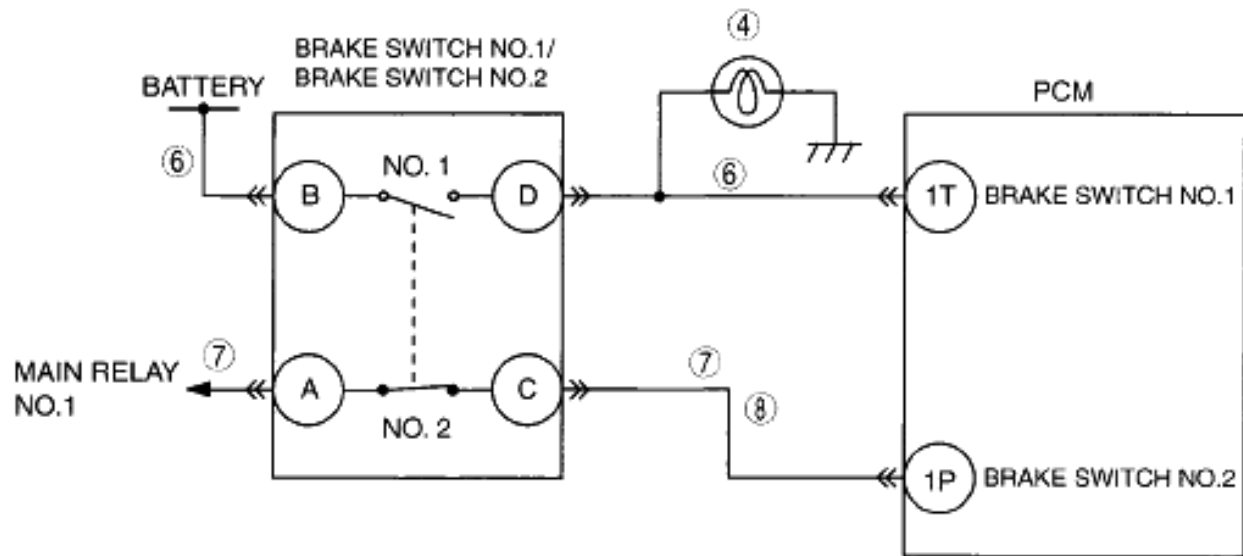

MAIN RELAY NO.1

BRAKE SWITCH NO.1/  
BRAKE SWITCH NO.2

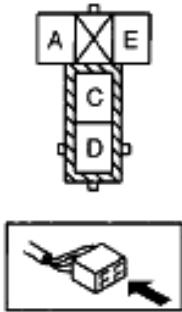

PCM  
WIRING HARNESS-SIDE CONNECTOR

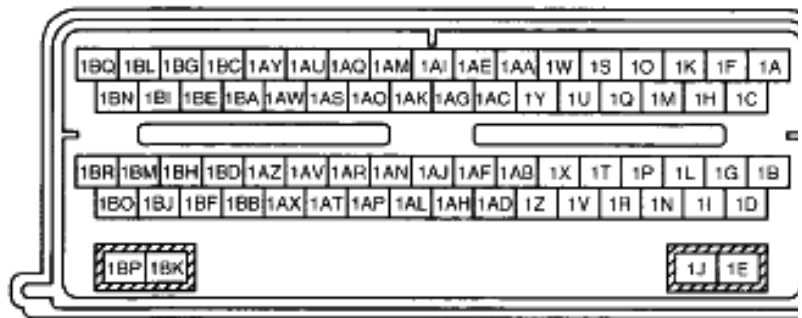

### DIAGNOSTIC PROCEDURE

#### DTC P1703 (MZI-3.5) DIAGNOSTIC PROCEDURE

STEP	INSPECTION		ACTION
1	<b>VERIFY FREEZE FRAME DATA HAS BEEN RECORDED</b> <ul style="list-style-type: none"> <li>Has FREEZE FRAME DATA been recorded?</li> </ul>	Yes	Go to next step.
		No	Record FREEZE FRAME DATA on the repair order, then go to next step.
2	<b>VERIFY RELATED REPAIR INFORMATION AVAILABILITY</b> <ul style="list-style-type: none"> <li>Verify related Service Bulletins</li> </ul>	Yes	Perform repair or diagnosis according to available Service Bulletins. <ul style="list-style-type: none"> <li>If vehicle is not repaired, go to next</li> </ul>

## 2007 Mazda CX-9 Grand Touring

2007 ENGINE PERFORMANCE On-Board Diagnostic (MZI-3.5) - CX-9

	availability.		step.
	<ul style="list-style-type: none"> <li>Is any related Service Bulletins available?</li> </ul>	No	Go to next step.
3	<b>VERIFY THE BRAKE PEDAL WAS APPLIED</b> <ul style="list-style-type: none"> <li>Was the brake pedal applied and released during the KOEO self-test?</li> </ul>	Yes	Go to next step.
		No	Perform the KOER self-test. Apply and release the brake pedal during the KORE test, then go to Step 10 (See <b>KOEO/KOER SELF TEST [MZI-3.5].</b> )
4	<b>INSPECT THE OPERATION OF THE BRAKE/TAILLIGHT</b> <ul style="list-style-type: none"> <li>Turn the ignition switch to the ON position (Engine off).</li> <li>Depress and release the brake pedal and check the brake/taillight operation.</li> <li>Do the brake/taillight operate correctly?</li> </ul>	Yes	Go to next step.
		No	Repair or replace harness or brake/taillight, then go to Step 10.
5	<b>INSPECT THE CRUISE CONTROL OPERATION</b> <ul style="list-style-type: none"> <li>Check for cruise control operation.</li> <li>Does the cruise control operate correctly?</li> </ul>	Yes	Go to next step.
		No	Repair or replace suspected part, then go to Step 10.
6	<b>INSPECT BRAKE SWITCH AND PCM CONNECTOR FOR POOR CONNECTION</b> <ul style="list-style-type: none"> <li>Turn the ignition switch off.</li> <li>Disconnect the throttle body connector.</li> <li>Inspect for poor connection (such as damaged/pulled-out pins, corrosion).</li> <li>Are there any malfunction?</li> </ul>	Yes	Repair or replace suspected part, then go to Step 10.
		No	Go to the next step.
7	<b>INSPECT BRAKE SWITCH NO.1 CIRCUIT MALFUNCTION</b> <ul style="list-style-type: none"> <li>Turn the ignition switch to the ON position (Engine off).</li> <li>Measure the voltage between PCM terminal 1T (wiring harness-side) and body ground.</li> </ul>	Yes	Go to next step.
		No	Repair or replace suspected part, then go to Step 10.

## 2007 Mazda CX-9 Grand Touring

2007 ENGINE PERFORMANCE On-Board Diagnostic (MZI-3.5) - CX-9

	<ul style="list-style-type: none"> <li>• Verify the following values when the brake pedal to the floor and releasing. <ul style="list-style-type: none"> <li>○ Brake pedal fully depressed: more than 10 V</li> <li>○ Brake pedal fully released: less than 1.0 V</li> </ul> </li> <li>• Is the voltage normal?</li> </ul>		
8	<p><b>INSPECT BRAKE SWITCH</b></p> <ul style="list-style-type: none"> <li>• Inspect the brake switch.</li> </ul> <p>(see <b><u>BRAKE SWITCH INSPECTION</u></b> .)</p> <ul style="list-style-type: none"> <li>• Is there any malfunction?</li> </ul>	Yes	Repair or replace suspected part, then go to Step 10.
		No	Go to the next step.
9	<p><b>INSPECT FOR CORRECT PCM OPERATION</b></p> <ul style="list-style-type: none"> <li>• Disconnect all the PCM connectors.</li> <li>• Visually inspect for: <ul style="list-style-type: none"> <li>○ Pushed out pins</li> <li>○ Corrosion</li> </ul> </li> <li>• Connect all the PCM connectors and verify that they seat correctly.</li> <li>• Retrieve DTCs using the M-MDS.</li> <li>• Is the PENDING CODE for this DTC present?</li> </ul>	Yes	Go to the next step.
		No	The system is correctly. Go to the next step.
10	<p><b>VERIFY TROUBLESHOOTING OF DTC P1703 HAS BEEN COMPLETED</b></p> <ul style="list-style-type: none"> <li>• Verify that all disconnected connectors reconnected.</li> <li>• Clear DTC from memory using M-MDS.</li> <li>• Perform KOEO/KOER Self-Test.</li> <li>• Is PENDING CODE same as DTC present?</li> </ul>	Yes	Replace the PCM, then go to next step. (see <b><u>PCM REMOVAL/INSTALLATION [MZI-3.5]</u></b> .)
		No	Go to next step.
11	<p><b>VERIFY AFTER REPAIR PROCEDURE</b></p>	Yes	Go to the applicable DTC inspection. (See <b><u>DTC TABLE [MZI-3.5]</u></b> .)

## 2007 Mazda CX-9 Grand Touring

2007 ENGINE PERFORMANCE On-Board Diagnostic (MZI-3.5) - CX-9

<ul style="list-style-type: none"> <li>• Perform "AFTER REPAIR PROCEDURE".</li>   <li>(See <b><u>AFTER REPAIR PROCEDURE [MZI-3.5].</u></b>)</li>   <li>• Are any DTCs present?</li> </ul>	No	Troubleshooting completed.
---	----	----------------------------

### DTC P2100 [MZI-3.5]

#### DTC P2100 (MZI-3.5) DETECTION CONDITION AND POSSIBLE CAUSES

<b>DTC P2100</b>	<b>Throttle actuator circuit open</b>
<b>DETECTION CONDITION</b>	<ul style="list-style-type: none"> <li>• A PCM malfunction flag is set indicating the motor circuit is open.</li> </ul>
<b>POSSIBLE CAUSE</b>	<ul style="list-style-type: none"> <li>• Throttle actuator malfunction</li> <li>• Connector or terminal malfunction</li> <li>• Open circuit wiring harness between throttle body terminal A and PCM terminal 2</li> <li>• Short to power supply in wiring harness between throttle body terminal A and PC terminal 2BO</li> <li>• Open circuit wiring harness between throttle body terminal B and PCM terminal 2</li> <li>• Short to power supply in wiring harness between throttle body terminal B and PC terminal 2BR</li> <li>• Throttle actuator circuits are shorted each other</li> </ul>

## 2007 Mazda CX-9 Grand Touring

2007 ENGINE PERFORMANCE On-Board Diagnostic (MZI-3.5) - CX-9

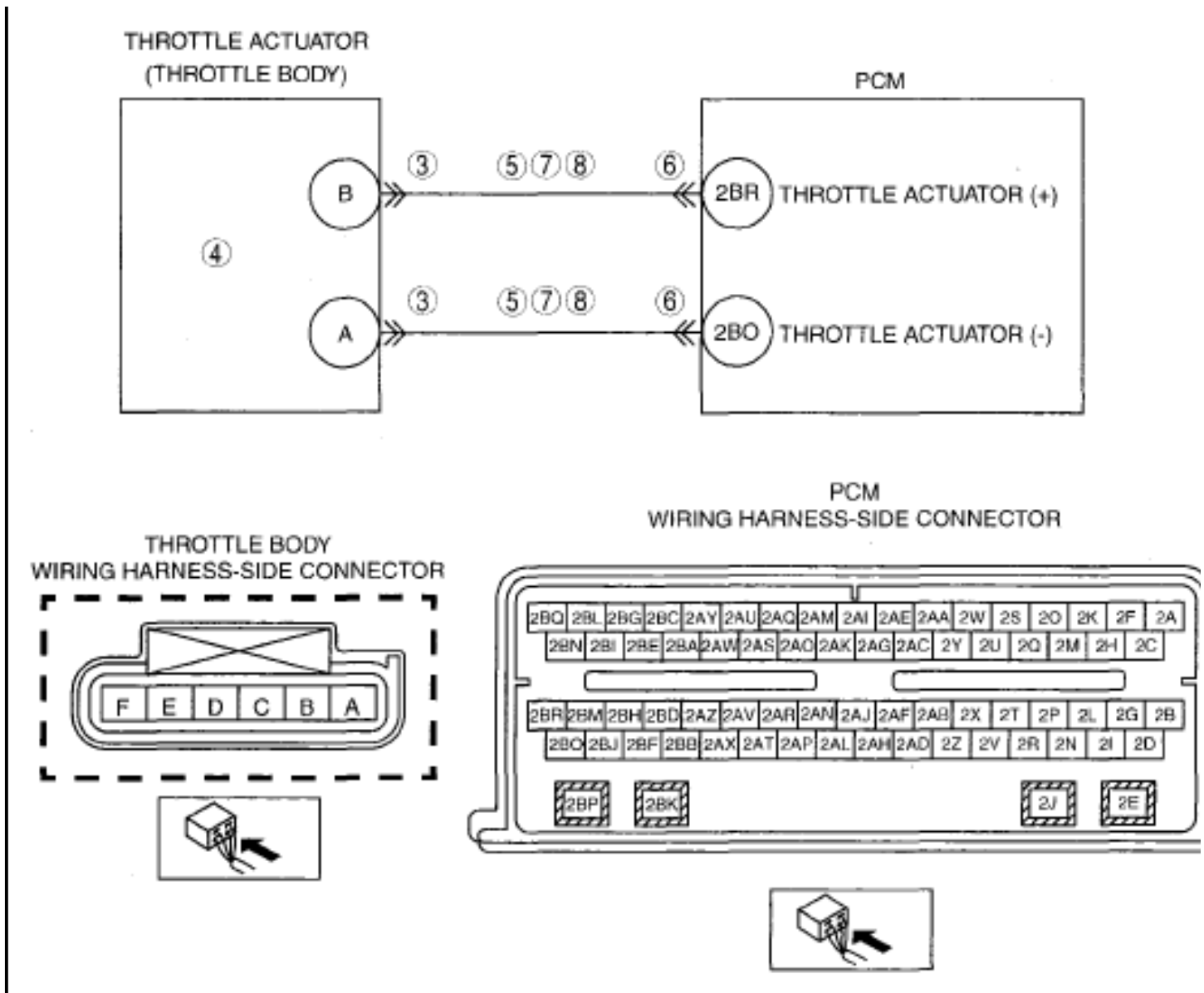

### DIAGNOSTIC PROCEDURE

#### DTC P2100 (MZI-3.5) DIAGNOSTIC PROCEDURE

STEP	INSPECTION		ACTION
1	<b>VERIFY FREEZE FRAME DATA HAS BEEN RECORDED</b>	Yes	Go to the next step.
		No	Record FREEZE FRAME DATA on the repair order, then go to the next step.
2	<b>VERIFY RELATED REPAIR INFORMATION AVAILABILITY</b>	Yes	Perform repair or diagnosis according to the available Service Bulletins.

## 2007 Mazda CX-9 Grand Touring

2007 ENGINE PERFORMANCE On-Board Diagnostic (MZI-3.5) - CX-9

	<ul style="list-style-type: none"> <li>• Verify related Service Bulletins and/or on-line repair information availability.</li> <li>• Is any related Service Bulletins available?</li> </ul>		<ul style="list-style-type: none"> <li>• If the vehicle is not repaired, go to the next step.</li> </ul>
		No	Go to the next step.
3	<p><b>INSPECT THROTTLE BODY CONNECTOR FOR POOR CONNECTION</b></p> <ul style="list-style-type: none"> <li>• Turn the ignition switch to the ON position (Engine off).</li> <li>• Disconnect the throttle body connector.</li> <li>• Inspect for poor connection (such as damaged/pulled-out pins, corrosion).</li> <li>• Are there any malfunction?</li> </ul>	Yes	Repair or replace suspected part, then go to Step 9.
		No	Go to the next step.
4	<p><b>INSPECT THE THROTTLE ACTUATOR</b></p> <ul style="list-style-type: none"> <li>• Inspect the throttle actuator.</li> </ul> <p>(see <b><u>THROTTLE BODY INSPECTION [MZI-3.5]</u></b> .)</p> <ul style="list-style-type: none"> <li>• Is there malfunction?</li> </ul>	Yes	Replace the throttle body, then go to Step 9. (see <b><u>INTAKE-AIR SYSTEM REMOVAL/INSTALLATION [MZI-3.5]</u></b> .)
		No	Go to the next step.
5	<p><b>INSPECT PCM CONNECTOR FOR POOR CONNECTION</b></p> <ul style="list-style-type: none"> <li>• Turn the ignition switch off.</li> <li>• Disconnect the PCM connector.</li> <li>• Inspect for poor connection (such as damaged/pulled-out pins, corrosion).</li> <li>• Is there any malfunction?</li> </ul>	Yes	Repair or replace suspected part, then go to Step 9.
		No	Go to the next step.
6	<p><b>INSPECT THROTTLE ACTUATOR CONTROL CIRCUIT FOR OPEN</b></p> <ul style="list-style-type: none"> <li>• Disconnect the PCM connector.</li> <li>• Inspect for continuity between the following terminals: <ul style="list-style-type: none"> <li>○ Throttle body terminal A and PCM terminal 2BO</li> </ul> </li> </ul>	Yes	Go to the next step.
		No	Repair or replace suspected part, then go to Step 9.

## 2007 Mazda CX-9 Grand Touring

2007 ENGINE PERFORMANCE On-Board Diagnostic (MZI-3.5) - CX-9

	<ul style="list-style-type: none"> <li>○ Throttle body terminal B and PCM terminal 2BR</li> <li>● Are there continuity?</li> </ul>		
7	<p><b>INSPECT TP SENSOR SIGNAL CIRCUITS FOR SHORT EACH OTHER</b></p> <ul style="list-style-type: none"> <li>● Turn the ignition switch off.</li> <li>● Disconnect the throttle body and PCM connector.</li> <li>● Measure resistance between throttle body terminal A and B.</li> <li>● Is the resistance <b>more than 10 kilohms?</b></li> </ul>	Yes	Go to the next step.
		No	Repair or replace suspected part, then go to Step 9.
8	<p><b>INSPECT THROTTLE ACTUATOR CONTROL CIRCUIT FOR SHORT TO POWER SUPPLY</b></p> <ul style="list-style-type: none"> <li>● Turn the ignition switch to the ON position (Engine off).</li> <li>● Measure the voltage between the following terminals:                             <ul style="list-style-type: none"> <li>○ Throttle body terminal A and body ground.</li> <li>○ Throttle body terminal B and body ground.</li> </ul> </li> <li>● Are there voltage B+?</li> </ul>	Yes	Repair or replace suspected part, then go to the next step.
		No	Go to the next step.
9	<p><b>VERIFY TROUBLESHOOTING OF DTC P2100 HAS BEEN COMPLETED</b></p> <ul style="list-style-type: none"> <li>● Verify that all disconnected connectors reconnected.</li> <li>● Clear the DTC from the PCM memory using the M-MDS.</li> <li>● Perform the KOEO or KOER self-test using the M-MDS.</li> </ul> <p>(See <b><u>KOEO/KOER SELF TEST [MZI-3.5].</u></b>)</p> <ul style="list-style-type: none"> <li>● Is the PENDING CODE for the DTC present?</li> </ul>	Yes	Replace the PCM, then go to the next step. (see <b><u>PCM REMOVAL/INSTALLATION [MZI-3.5]</u></b> .)
		No	Go to the next step.



## 2007 Mazda CX-9 Grand Touring

2007 ENGINE PERFORMANCE On-Board Diagnostic (MZI-3.5) - CX-9

10	<b>VERIFY AFTER REPAIR PROCEDURE</b>  • Perform "AFTER REPAIR PROCEDURE".  (See <b>AFTER REPAIR PROCEDURE [MZI-3.5]</b> .)  • Are any DTCs present?	Yes	Go to the applicable DTC inspection. (See <b>DTC TABLE [MZI-3.5]</b> .)
		No	Troubleshooting completed.

### DTC P2101 [MZI-3.5]

#### DTC P2101 (MZI-3.5) DETECTION CONDITION AND POSSIBLE CAUSES

<b>DTC P2101</b>	<b>Throttle actuator circuit range/performance</b>
<b>DETECTION CONDITION</b>	<ul style="list-style-type: none"><li>• A PCM malfunction flag is set indicating the motor circuit is open, and may require cycling the key.</li></ul>
<b>POSSIBLE CAUSE</b>	<ul style="list-style-type: none"><li>• Throttle actuator circuit are cross-wired</li></ul>

## 2007 Mazda CX-9 Grand Touring

2007 ENGINE PERFORMANCE On-Board Diagnostic (MZI-3.5) - CX-9

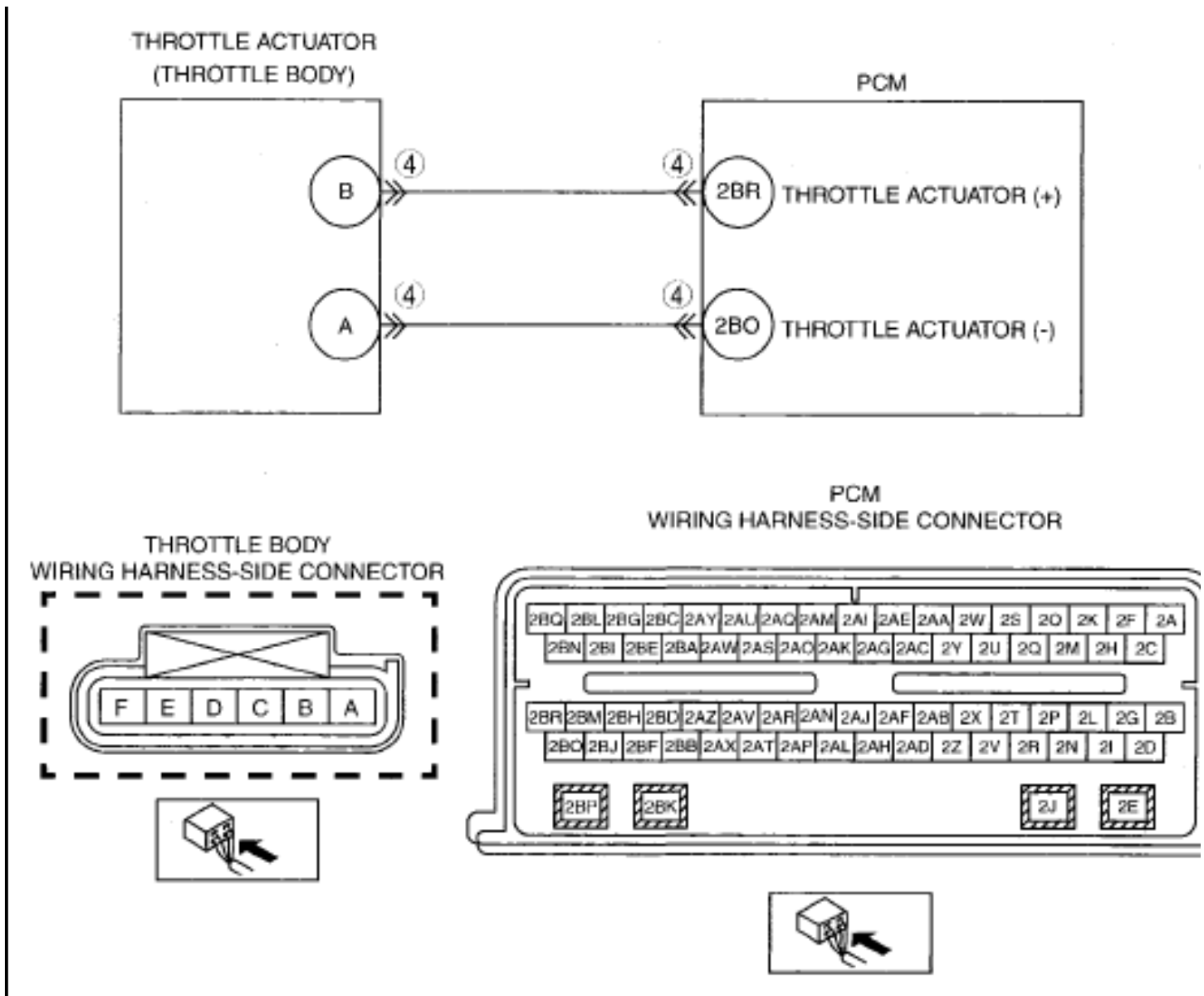

### DIAGNOSTIC PROCEDURE

#### DTC P2101 (MZI-3.5) DIAGNOSTIC PROCEDURE

STEP	INSPECTION		ACTION
1	<b>VERIFY FREEZE FRAME DATA HAS BEEN RECORDED</b> <ul style="list-style-type: none"> <li>Has FREEZE FRAME DATA been recorded?</li> </ul>	Yes	Go to the next step.
		No	Record FREEZE FRAME DATA on the repair order, then go to the next step.
2	<b>VERIFY RELATED REPAIR INFORMATION AVAILABILITY</b>	Yes	Perform repair or diagnosis according to the available Service Bulletins.

## 2007 Mazda CX-9 Grand Touring

2007 ENGINE PERFORMANCE On-Board Diagnostic (MZI-3.5) - CX-9

	<ul style="list-style-type: none"> <li>• Verify related Service Bulletins and/or on-line repair information availability.</li> <li>• Is any related Service Bulletins available?</li> </ul>		<ul style="list-style-type: none"> <li>• If the vehicle is not repaired, go to the next step.</li> </ul>
		No	Go to the next step.
3	<p><b>VERIFY RELATED PENDING CODE OR STORED DTCs FOR ALL OF VEHICLE MODULE</b></p> <ul style="list-style-type: none"> <li>• Turn the ignition switch off then to the ON position (Engine off).</li> <li>• Verify related pending code or stored DTCs.</li> <li>• Is other DTCs present?</li> </ul>	Yes	Go to the appropriate DTC troubleshooting. (See <b><u>DTC TABLE [MZI-3.5]</u></b> .)
		No	Go to the next step.
4	<p><b>INSPECT THROTTLE BODY AND PCM CONNECTOR FOR POOR CONNECTION</b></p> <ul style="list-style-type: none"> <li>• Turn the ignition switch off.</li> <li>• Disconnect the throttle body and PCM connector.</li> <li>• Inspect for poor connection (such as damaged/pulled-out pins, corrosion).</li> <li>• Are there any malfunction?</li> </ul>	Yes	Repair or replace suspected part, then go to Step 6.
		No	Go to the next step.
5	<p><b>INSPECT FOR CORRECT PCM OPERATION</b></p> <ul style="list-style-type: none"> <li>• Disconnect all the PCM connectors.</li> <li>• Visually inspect for: <ul style="list-style-type: none"> <li>○ Pushed out pins</li> <li>○ Corrosion</li> </ul> </li> <li>• Connect all the PCM connectors and verify that they seat correctly.</li> <li>• Retrieve DTCs using the M-MDS.</li> <li>• Is the PENDING CODE for this DTC present?</li> </ul>	Yes	Go to the next step.
		No	The system is correctly. Go to the next step.
6	<p><b>VERIFY TROUBLESHOOTING OF DTC P2101 HAS BEEN COMPLETED</b></p> <ul style="list-style-type: none"> <li>• Verify that all disconnected</li> </ul>	Yes	Replace the PCM, then go to the next step. (see <b><u>PCM REMOVAL/INSTALLATION [MZI-3.5]</u></b> .)

## 2007 Mazda CX-9 Grand Touring

2007 ENGINE PERFORMANCE On-Board Diagnostic (MZI-3.5) - CX-9

	<p>connectors reconnected.</p> <ul style="list-style-type: none"> <li>Start the engine.</li> <li>Clear DTC from PCM memory using M-MDS.</li> <li>Perform the "KOEO/KOER Self-Test".</li> </ul> <p>(See <b><u>KOEO/KOER SELF TEST [MZI-3.5].</u></b>)</p> <ul style="list-style-type: none"> <li>Is same DTC present?</li> </ul>	No	Go to the next step.
7	<p><b>VERIFY AFTER REPAIR PROCEDURE</b></p> <ul style="list-style-type: none"> <li>Perform the "AFTER REPAIR PROCEDURE".</li> </ul> <p>(See <b><u>AFTER REPAIR PROCEDURE [MZI-3.5].</u></b>)</p> <ul style="list-style-type: none"> <li>Are any DTCs present?</li> </ul>	Yes	Go to the applicable DTC inspection. (See <b><u>DTC TABLE [MZI-3.5].</u></b> )
		No	Troubleshooting completed.

### DTC P2104, P2105, P2110 [MZI-3.5]

#### DTC P2104, P2105, P2110 (MZI-3.5) DETECTION CONDITION AND POSSIBLE CAUSES

<b>DTC P2104</b>	<b>P2104: Throttle actuator control system - forced idle</b>
<b>DTC P2105</b>	<b>P2105: Throttle actuator control system - forced engine shutdown</b>
<b>DTC P2110</b>	<b>P2110: Throttle actuator control system - forced limited RPM</b>
<b>DETECTION CONDITION</b>	<ul style="list-style-type: none"> <li>The TAC system is in the failure mode effects management (FMEM) mode.</li> </ul>
<b>POSSIBLE CAUSE</b>	<ul style="list-style-type: none"> <li>This DTC is an informational DTC and may be set in combination with a number of other DTCs which are causing the FMEM. Diagnose other DTCs first.</li> </ul>

#### DIAGNOSTIC PROCEDURE

#### DTC P2104, P2105, P2110 (MZI-3.5) DIAGNOSTIC PROCEDURE

STEP	INSPECTION		ACTION
1	<p><b>VERIFY FREEZE FRAME DATA HAS BEEN RECORDED</b></p> <ul style="list-style-type: none"> <li>Has FREEZE FRAME DATA been recorded?</li> </ul>	Yes	Go to the next step.
		No	Record FREEZE FRAME DATA on the repair order, then go to the next step.
2	<b>VERIFY RELATED REPAIR</b>	Yes	Perform repair or diagnosis according to

## 2007 Mazda CX-9 Grand Touring

2007 ENGINE PERFORMANCE On-Board Diagnostic (MZI-3.5) - CX-9

	<p><b>INFORMATION AVAILABILITY</b></p> <ul style="list-style-type: none"> <li>• Verify related Service Bulletins and/or on-line repair information availability.</li> <li>• Is any related Service Bulletins available?</li> </ul>		<p>the available Service Bulletins.</p> <ul style="list-style-type: none"> <li>• If the vehicle is not repaired, go to the next step.</li> </ul>
		No	<p>Perform the PCM reprogramming procedure. (see <b><u>PCM CONFIGURATION [MZI-3.5]</u></b> .) Then go to the next step.</p>
3	<p><b>VERIFY RELATED PENDING CODE OR STORED DTCs FOR ALL OF VEHICLE MODULE</b></p> <ul style="list-style-type: none"> <li>• Turn the ignition switch off then to the ON position (Engine off).</li> <li>• Verify related pending code or stored DTCs.</li> <li>• Is other DTCs present?</li> </ul>	Yes	<p>Go to the appropriate DTC troubleshooting. (See <b><u>DTC TABLE [MZI-3.5]</u></b>.)</p>
		No	<p>Go to the next step.</p>
4	<p><b>PERFORM VISUAL INSPECTION</b></p> <ul style="list-style-type: none"> <li>• Turn the ignition switch off.</li> <li>• Visually inspect the following for obvious signs of damage: <ul style="list-style-type: none"> <li>○ Throttle body</li> <li>○ PCM</li> </ul> </li> <li>• Is a concern present?</li> </ul>	Yes	<p>Isolate the concern and repair if necessary. Then go to Step 6.</p>
		No	<p>Go to the next step.</p>
5	<p><b>INSPECT ACCELERATOR PEDAL POSITION (APP) SENSOR</b></p> <ul style="list-style-type: none"> <li>• Perform the APP sensor inspection  (see <b><u>ACCELERATOR PEDAL POSITION (APP) SENSOR INSPECTION [MZI-3.5]</u></b> .)</li> <li>• Is a concern present?</li> </ul>	Yes	<p>Repair or replace if necessary. Then go to the next step.</p>
		No	<p>Go to the next step.</p>
6	<p><b>VERIFY TROUBLESHOOTING OF MISFIRE DTC HAS BEEN COMPLETED</b></p> <ul style="list-style-type: none"> <li>• Verify that all disconnected connectors are reconnected.</li> <li>• Turn the ignition switch to the ON position (Engine off).</li> </ul>	Yes	<p>Replace the PCM, then go to the next step. (see <b><u>PCM REMOVAL/INSTALLATION [MZI-3.5]</u></b> .)</p>

## 2007 Mazda CX-9 Grand Touring

2007 ENGINE PERFORMANCE On-Board Diagnostic (MZI-3.5) - CX-9

	<ul style="list-style-type: none"> <li>• Clear the DTC from the PCM memory using the M-MDS.</li> <li>• Perform the KOEO and KOER self test.</li> <li>• Retrieve DTCs using the M-MDS.</li> <li>• Is the PENDING CODE for this DTC present?</li> </ul>	No	Go to the next step.
7	<p><b>VERIFY AFTER REPAIR PROCEDURE</b></p> <ul style="list-style-type: none"> <li>• Perform "AFTER REPAIR PROCEDURE".</li> </ul> <p>(See <b><u>AFTER REPAIR PROCEDURE [MZI-3.5].</u></b>)</p> <ul style="list-style-type: none"> <li>• Are any DTC present?</li> </ul>	Yes	Go to the applicable DTC inspection. (See <b><u>DTC TABLE [MZI-3.5].</u></b> )
		No	Troubleshooting completed.

### DTC P2107 [MZI-3.5]

#### DTC P2107 (MZI-3.5) DETECTION CONDITION AND POSSIBLE CAUSES

<b>DTC P2107</b>	<b>Throttle actuator control module processor</b>
<b>DETECTION CONDITION</b>	<ul style="list-style-type: none"> <li>• The throttle actuator control area of the PCM failed the self-test.</li> </ul>
<b>POSSIBLE CAUSE</b>	<ul style="list-style-type: none"> <li>• Throttle body malfunction</li> <li>• Throttle actuator control circuits are shorted each other</li> <li>• Short to power supply between throttle actuator terminal A and PCM terminal 2B</li> <li>• Short to power supply between throttle actuator terminal B and PCM terminal 2B</li> <li>• PCM malfunction</li> </ul>

## 2007 Mazda CX-9 Grand Touring

2007 ENGINE PERFORMANCE On-Board Diagnostic (MZI-3.5) - CX-9

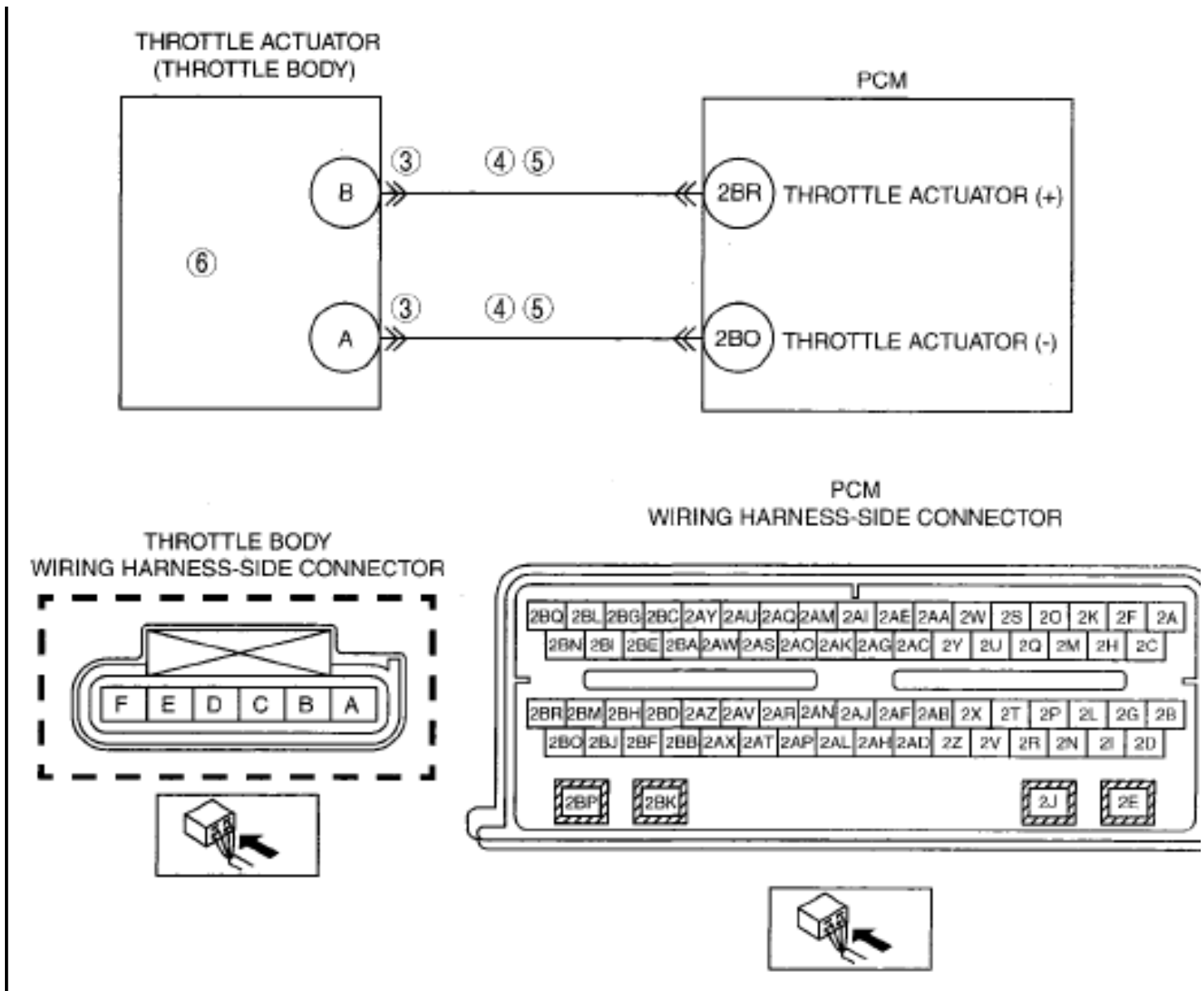

### DIAGNOSTIC PROCEDURE

#### DTC P2107 (MZI-3.5) DIAGNOSTIC PROCEDURE

STEP	INSPECTION		ACTION
1	<b>VERIFY FREEZE FRAME DATA HAS BEEN RECORDED</b>	Yes	Go to the next step.
		No	Record the FREEZE FRAME DATA on the repair order, then go to the next step.
2	<b>VERIFY RELATED REPAIR INFORMATION AVAILABILITY</b>	Yes	Perform repair or diagnosis according to the available Service Bulletins.

## 2007 Mazda CX-9 Grand Touring

2007 ENGINE PERFORMANCE On-Board Diagnostic (MZI-3.5) - CX-9

	<ul style="list-style-type: none"> <li>• Verify related Service Bulletins and/or on-line repair information availability.</li> <li>• Is any related Service Bulletins available?</li> </ul>		<ul style="list-style-type: none"> <li>• If the vehicle is not repaired, go to the next step.</li> </ul>
		No	Go to the next step.
3	<p><b>INSPECT MAP SENSOR CONNECTOR FOR POOR CONNECTION</b></p> <ul style="list-style-type: none"> <li>• Turn the ignition switch off.</li> <li>• Disconnect the MAF/IAT sensor connector.</li> <li>• Inspect for poor connection (such as damaged/pulled-out pins, corrosion).</li> <li>• Are there any malfunction?</li> </ul>	Yes	Repair or replace suspected part, then go to Step 8.
		No	Go to the next step.
4	<p><b>INSPECT THROTTLE ACTUATOR CONTROL CIRCUIT FOR SHORT TO POWER SUPPLY</b></p> <ul style="list-style-type: none"> <li>• Turn the ignition switch to the ON position (Engine off).</li> <li>• Measure voltage between the following circuits: <ul style="list-style-type: none"> <li>○ Throttle actuator terminal A (wiring harness-side) and body ground.</li> <li>○ Throttle actuator terminal B (wiring harness-side) and body ground.</li> </ul> </li> <li>• Are there voltage B+?</li> </ul>	Yes	Repair or replace suspected part, then go to Step 8.
		No	Go to the next step.
5	<p><b>INSPECT THROTTLE ACTUATOR CONTROL CIRCUITS FOR SHORT EACH OTHER</b></p> <ul style="list-style-type: none"> <li>• Turn the ignition switch off.</li> <li>• Disconnect the throttle body and PCM connector.</li> <li>• Measure resistance between throttle actuator terminal A and B.</li> <li>• Is the resistance <b>more than 10 kilohms</b>?</li> </ul>	Yes	Go to the next step.
		No	Repair or replace suspected part, then go to Step 8.
6	<p><b>INSPECT THROTTLE ACTUATOR</b></p>	Yes	Replace the throttle body, then go to Step



## 2007 Mazda CX-9 Grand Touring

2007 ENGINE PERFORMANCE On-Board Diagnostic (MZI-3.5) - CX-9

	<ul style="list-style-type: none"> <li>Inspect the throttle actuator.</li> </ul> <p>(see <b><u>THROTTLE BODY INSPECTION [MZI-3.5]</u></b> .)</p>		8. (see <b><u>INTAKE-AIR SYSTEM REMOVAL/INSTALLATION [MZI-3.5]</u></b> .)
	<ul style="list-style-type: none"> <li>Is there any malfunction?</li> </ul>	No	Go to the next step.
7	<p><b>INSPECT FOR CORRECT PCM OPERATION</b></p> <ul style="list-style-type: none"> <li>Disconnect all the PCM connectors.</li> <li>Visually inspect for: <ul style="list-style-type: none"> <li>Pushed out pins</li> <li>Corrosion</li> </ul> </li> <li>Connect all the PCM connectors and verify that they seat correctly.</li> <li>Retrieve DTCs using the M-MDS.</li> <li>Is the PENDING CODE for this DTC present?</li> </ul>	Yes	Go to the next step.
		No	The system is correctly. Go to the next step.
8	<p><b>VERIFY TROUBLESHOOTING OF DTC P2107 HAS BEEN COMPLETED</b></p> <ul style="list-style-type: none"> <li>Verify that all disconnected connectors reconnected.</li> <li>Start the engine.</li> <li>Clear DTC from PCM memory using M-MDS.</li> <li>Perform the "KOEO/KOER Self-Test".</li> </ul> <p>(See <b><u>KOEO/KOER SELF TEST [MZI-3.5]</u></b>.)</p>	Yes	Replace the PCM, then go to the next step. (see <b><u>PCM REMOVAL/INSTALLATION [MZI-3.5]</u></b> .)
	<ul style="list-style-type: none"> <li>Is same DTC present?</li> </ul>	No	Go to the next step.
9	<p><b>VERIFY AFTER REPAIR PROCEDURE</b></p> <ul style="list-style-type: none"> <li>Perform the "AFTER REPAIR PROCEDURE".</li> </ul> <p>(See <b><u>AFTER REPAIR PROCEDURE [MZI-3.5]</u></b>.)</p>	Yes	Go to the applicable DTC inspection. (See <b><u>DTC TABLE [MZI-3.5]</u></b> .)
		No	Troubleshooting completed.

## 2007 Mazda CX-9 Grand Touring

2007 ENGINE PERFORMANCE On-Board Diagnostic (MZI-3.5) - CX-9

- Are any DTCs present?

### DTC P2111 [MZI-3.5]

#### DTC P2111 (MZI-3.5) DETECTION CONDITION AND POSSIBLE CAUSES

<b>DTC P2111</b>	<b>Throttle actuator control system - stuck open</b>
<b>DETECTION CONDITION</b>	<ul style="list-style-type: none"><li>• This PCM fault status indicates the throttle plate is at a more angle than command</li></ul>
<b>POSSIBLE CAUSE</b>	<ul style="list-style-type: none"><li>• Binding throttle body, stuck open</li><li>• Throttle actuator control circuits are cross-wired</li><li>• Throttle actuator control circuits are shorted each other</li><li>• PCM malfunction</li></ul>

# 2007 Mazda CX-9 Grand Touring

2007 ENGINE PERFORMANCE On-Board Diagnostic (MZI-3.5) - CX-9

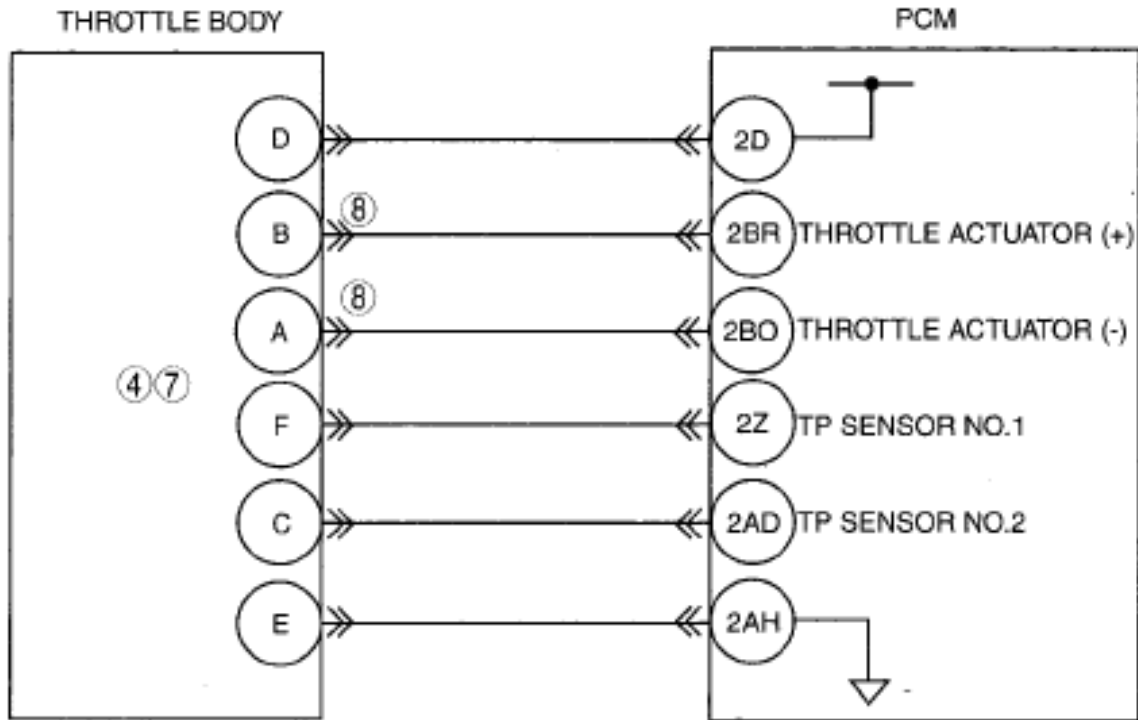

THROTTLE BODY  
WIRING HARNESS-SIDE CONNECTOR

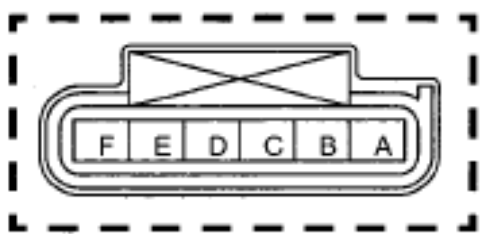

PCM  
WIRING HARNESS-SIDE CONNECTOR

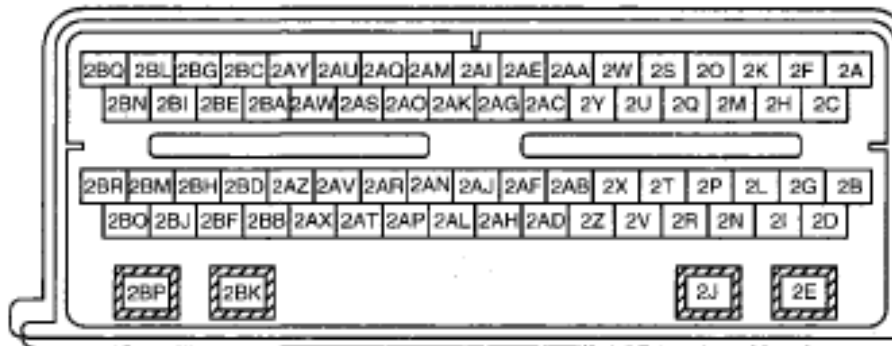

## DIAGNOSTIC PROCEDURE

### DTC P2111 (MZI-3.5) DIAGNOSTIC PROCEDURE

STEP	INSPECTION		ACTION
1	VERIFY FREEZE FRAME DATA HAS BEEN RECORDED	Yes	Go to the next step.

## 2007 Mazda CX-9 Grand Touring

2007 ENGINE PERFORMANCE On-Board Diagnostic (MZI-3.5) - CX-9

	<ul style="list-style-type: none"> <li>• Has FREEZE FRAME DATA been recorded?</li> </ul>	No	Record FREEZE FRAME DATA on the repair order, then go to the next step.
2	<b>VERIFY RELATED REPAIR INFORMATION AVAILABILITY</b> <ul style="list-style-type: none"> <li>• Verify related Service Bulletins and/or on-line repair information availability.</li> <li>• Is any related Service Bulletins available?</li> </ul>	Yes	Perform repair or diagnosis according to the available Service Bulletins. <ul style="list-style-type: none"> <li>• If the vehicle is not repaired, go to the next step.</li> </ul>
		No	Go to the next step.
3	<b>INSPECT THROTTLE POSITION OPEN CIRCUIT AND CLOSED VOLTAGES</b> <ul style="list-style-type: none"> <li>• Turn the ignition switch to the ON position (Engine off).</li> <li>• Access the PCM and monitor the TP1 and TP2 PIDs.</li> <li>• Verify the following values of the PIDs when depressing the accelerator pedal to the floor and releasing.               <ul style="list-style-type: none"> <li>○ Pedal fully released: TP1 is 3.7-4.7 V</li> <li>○ Pedal fully released: TP2 is 0.3-1.9 V</li> <li>○ Pedal fully depressed: TP1 is 0.7-2.9 V</li> <li>○ Pedal fully depressed: TP2 is 4.1-4.7 V</li> </ul> </li> <li>• Are both PIDs within the specification?</li> </ul>	Yes	Go to the Step 5.
		No	Go to the next step.
4	<b>INSPECT FOR OBSTRUCTION OF THROTTLE BODY</b> <p><b>WARNING:</b></p> <ul style="list-style-type: none"> <li>• <b>Substantial opening and closing torque is applied by this system. To prevent injury, be careful to keep fingers away from throttle mechanism when actuated. Failure to follow these instructions may result in personal injury.</b></li> </ul>	Yes	Go to the Step 7.
		No	Isolate and repair the obstruction. Then go to Step 9.

## 2007 Mazda CX-9 Grand Touring

2007 ENGINE PERFORMANCE On-Board Diagnostic (MZI-3.5) - CX-9

	<ul style="list-style-type: none"> <li>• Turn the ignition switch off.</li> <li>• Remove the air hose from the throttle body.</li> <li>• Visually inspect for throttle plate obstructions or sludge.</li> <li>• Slowly, push the throttle plate to wide open and release.</li> <li>• Does the throttle plate move freely to wide open and back?</li> </ul>		
5	<p><b>INSPECT TP SENSOR OPERATION</b></p> <ul style="list-style-type: none"> <li>• Turn the ignition switch to the ON position (Engine off).</li> <li>• Access the PCM and monitor the TP1 and TP2 PIDs.</li> <li>• Slowly press the accelerator pedal from fully released to fully depressed while observing the voltage readings.</li> <li>• Use the chart as a reference.</li> <li>• Inspect the TP sensor.</li> </ul> <p>(see <b><u>THROTTLE POSITION (TP) SENSOR INSPECTION [MZI-3.5]</u></b>.)</p> <ul style="list-style-type: none"> <li>• Do all signal values smoothly change when the accelerator is depressed?</li> </ul>	Yes	Go to the next step.
		No	Replace the throttle body. Then go to Step 9.
6	<p><b>INSPECT TP SENSOR CIRCUIT FOR INTERMITTENT CONCERN</b></p> <ul style="list-style-type: none"> <li>• Access the PCM and monitor the TP1 and TP2 PIDs.</li> <li>• Wiggle, shake, and bend the wiring harness from the TP to the PCM.</li> <li>• Are the voltages between 0.49-4.65 V?</li> </ul>	Yes	Go to the next step.
		No	Repair or replace suspected part, then go to Step 9.
7	<p><b>INSPECT THROTTLE ACTUATOR CONTROL MOTOR VISUALLY</b></p> <p><b>NOTE:</b></p>	Yes	Replace the throttle body. Then go to Step 9.

## 2007 Mazda CX-9 Grand Touring

2007 ENGINE PERFORMANCE On-Board Diagnostic (MZI-3.5) - CX-9

	<ul style="list-style-type: none"> <li>• <b>Make sure the throttle body connector is properly connected.</b></li> <li>• Turn the ignition switch off.</li> <li>• Inspect the throttle actuator control motor for damaged housing, wiring harness connector, and wiring harness.</li> <li>• Are there any concerns with the throttle actuator control motor hardware?</li> </ul>	No	Go to the next step.
8	<b>INSPECT THROTTLE ACTUATOR CONTROL CIRCUITS FOR SHORT EACH OTHER</b> <ul style="list-style-type: none"> <li>• Turn the ignition switch off.</li> <li>• Disconnect the throttle body and PCM connector.</li> <li>• Measure resistance between throttle actuator terminal A and B.</li> <li>• Is the resistance more than 10 kilohms?</li> </ul>	Yes	Go to the next step.
		No	Repair or replace suspected part, then go to the next step.
9	<b>VERIFY TROUBLESHOOTING OF DTC P2111 HAS BEEN COMPLETED</b> <ul style="list-style-type: none"> <li>• Verify that all disconnected connectors reconnected.</li> <li>• Clear the DTC from the PCM memory using the M-MDS.</li> <li>• Perform the "KOEO or KOER self-test" using the M-MDS.</li> </ul> <p>(See <b><u>KOEO/KOER SELF TEST [MZI-3.5].</u></b>)</p> <ul style="list-style-type: none"> <li>• Is the PENDING CODE for the DTC present?</li> </ul>	Yes	Replace the PCM, then go to the next step. (see <b><u>PCM REMOVAL/INSTALLATION [MZI-3.5]</u></b> .)
		No	Go to the next step.
10	<b>VERIFY AFTER REPAIR PROCEDURE</b> <ul style="list-style-type: none"> <li>• Perform the "AFTER REPAIR PROCEDURE".</li> </ul>	Yes	Go to the applicable DTC inspection. (See <b><u>DTC TABLE [MZI-3.5].</u></b> )

## 2007 Mazda CX-9 Grand Touring

2007 ENGINE PERFORMANCE On-Board Diagnostic (MZI-3.5) - CX-9

	<p>(See <b><u>AFTER REPAIR PROCEDURE [MZI-3.5].</u></b>)</p> <ul style="list-style-type: none"><li>• Are any DTCs present?</li></ul>	No	Troubleshooting completed.
--	--	----	----------------------------

### DTC P2112 [MZI-3.5]

#### DTC P2112 (MZI-3.5) DETECTION CONDITION AND POSSIBLE CAUSES

<b>DTC P2112</b>	<b>Throttle actuator control system - stuck closed</b>
<b>DETECTION CONDITION</b>	<ul style="list-style-type: none"><li>• This PCM fault status indicates the throttle plate is at a lower angle than command</li></ul>
<b>POSSIBLE CAUSE</b>	<ul style="list-style-type: none"><li>• Binding throttle body, stuck open</li><li>• Throttle actuator control circuits are cross-wired</li><li>• Throttle actuator control circuits are shorted each other</li><li>• PCM malfunction</li></ul>

# 2007 Mazda CX-9 Grand Touring

2007 ENGINE PERFORMANCE On-Board Diagnostic (MZI-3.5) - CX-9

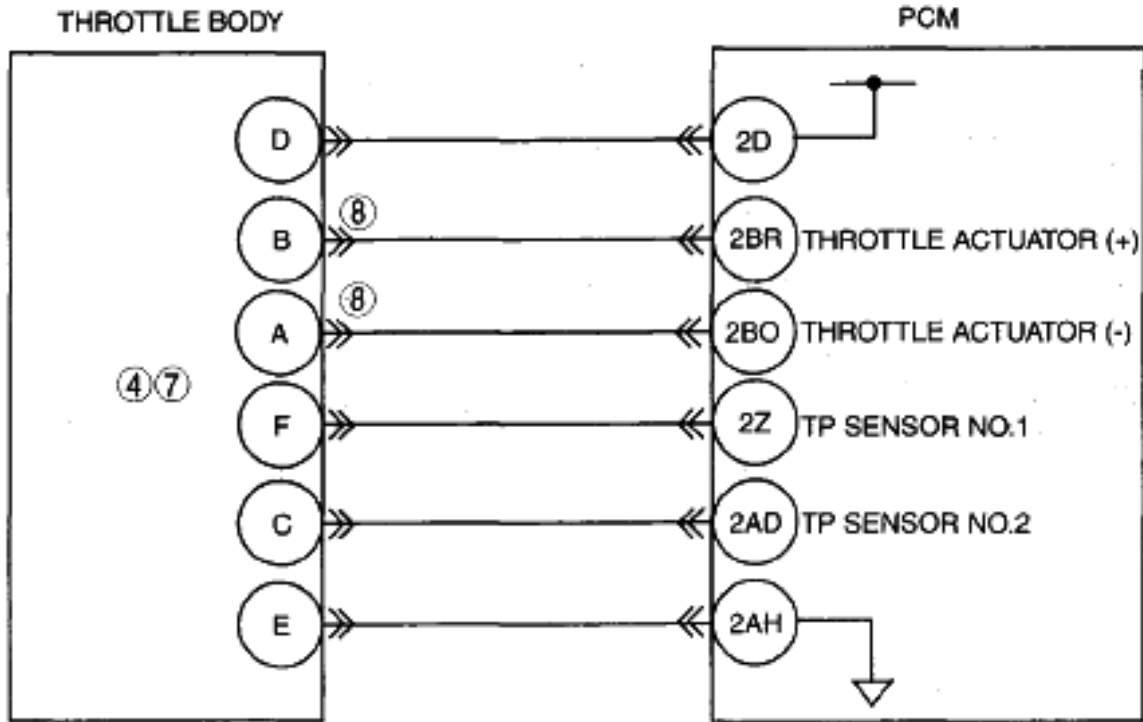

**THROTTLE BODY WIRING HARNESS-SIDE CONNECTOR**

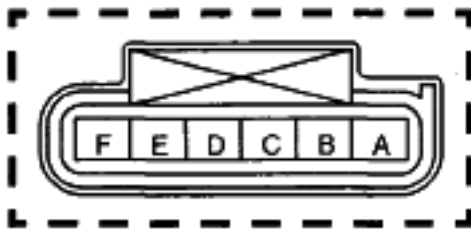

**PCM WIRING HARNESS-SIDE CONNECTOR**

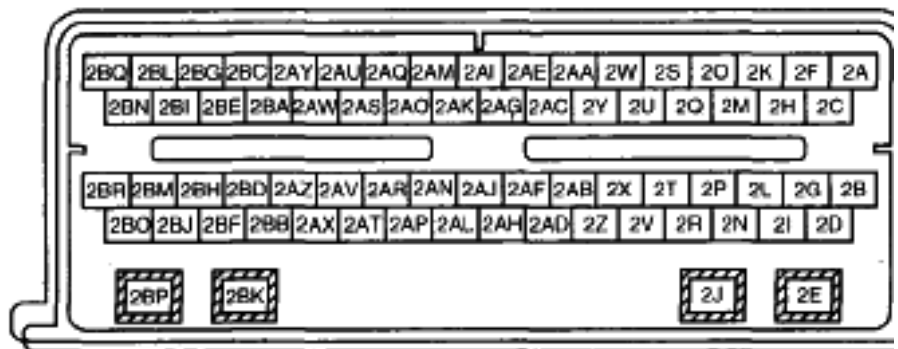

## DIAGNOSTIC PROCEDURE

### DTC P2112 (MZI-3.5) DIAGNOSTIC PROCEDURE

STEP	INSPECTION		ACTION
1	VERIFY FREEZE FRAME DATA HAS BEEN RECORDED	Yes	Go to the next step.



## 2007 Mazda CX-9 Grand Touring

2007 ENGINE PERFORMANCE On-Board Diagnostic (MZI-3.5) - CX-9

	<ul style="list-style-type: none"> <li>• Has FREEZE FRAME DATA been recorded?</li> </ul>	No	Record FREEZE FRAME DATA on the repair order, then go to the next step.
2	<b>VERIFY RELATED REPAIR INFORMATION AVAILABILITY</b> <ul style="list-style-type: none"> <li>• Verify related Service Bulletins and/or on-line repair information availability.</li> <li>• Is any related Service Bulletins available?</li> </ul>	Yes	Perform repair or diagnosis according to the available Service Bulletins. <ul style="list-style-type: none"> <li>• If the vehicle is not repaired, go to the next step.</li> </ul>
		No	Go to the next step.
3	<b>INSPECT THROTTLE POSITION OPEN CIRCUIT AND CLOSED VOLTAGES</b> <ul style="list-style-type: none"> <li>• Turn the ignition switch to the ON position (Engine off).</li> <li>• Access the PCM and monitor the TP1 and TP2 PIDs,</li> <li>• Verify the following values of the PIDs when depressing the accelerator pedal to the floor and releasing.               <ul style="list-style-type: none"> <li>○ Pedal fully released: TP1 is 3.7-4.7 V</li> <li>○ Pedal fully released: TP2 is 0.3-1.9 V</li> <li>○ Pedal fully depressed: TP1 is 0.7-2.9 V</li> <li>○ Pedal fully depressed: TP2 is 4.1-4.7 V</li> </ul> </li> <li>• Are both PIDs within the specification?</li> </ul>	Yes	Go to the Step 5.
		No	Go to the next step.
4	<b>INSPECT FOR OBSTRUCTION OF THROTTLE BODY</b> <p><b>WARNING:</b></p> <ul style="list-style-type: none"> <li>• <b>Substantial opening and closing torque is applied by this system. To prevent injury, be careful to keep fingers away from throttle mechanism when actuated. Failure to follow these instructions may result in personal injury.</b></li> </ul>	Yes	Go to the Step 7.
		No	Isolate and repair the obstruction. Then go to Step 9.

## 2007 Mazda CX-9 Grand Touring

2007 ENGINE PERFORMANCE On-Board Diagnostic (MZI-3.5) - CX-9

	<ul style="list-style-type: none"> <li>• Turn the ignition switch off.</li> <li>• Remove the air hose from the throttle body.</li> <li>• Visually inspect for throttle plate obstructions or sludge.</li> <li>• Slowly, push the throttle plate to wide open and release.</li> <li>• Does the throttle plate move freely to wide open and back?</li> </ul>		
5	<p><b>INSPECT TP SENSOR OPERATION</b></p> <ul style="list-style-type: none"> <li>• Turn the ignition switch to the ON position (Engine off).</li> <li>• Access the PCM and monitor the TP1 and TP2 PIDs.</li> <li>• Slowly press the accelerator pedal from fully released to fully depressed while observing the voltage readings.</li> <li>• Use the chart as a reference.</li> <li>• Inspect the TP sensor.</li> </ul> <p>(see <b><u>THROTTLE POSITION (TP) SENSOR INSPECTION [MZI-3.5].</u></b>)</p> <ul style="list-style-type: none"> <li>• Do all signal values smoothly change when the accelerator is depressed?</li> </ul>	Yes	Go to the next step.
		No	Replace the throttle body. Then go to Step 9.
6	<p><b>INSPECT TP SENSOR CIRCUIT FOR INTERMITTENT CONCERN</b></p> <ul style="list-style-type: none"> <li>• Access the PCM and monitor the TP1 and TP2 PIDs.</li> <li>• Wiggle, shake, and bend the wiring harness from the TP to the PCM.</li> <li>• Are the voltages between 0.49-4.65 V?</li> </ul>	Yes	Go to the next step.
		No	Repair or replace suspected part, then go to Step 9.
7	<p><b>INSPECT THROTTLE ACTUATOR CONTROL MOTOR VISUALLY</b></p> <p><b>NOTE:</b></p>	Yes	Replace the throttle body. Then go to Step 9.

## 2007 Mazda CX-9 Grand Touring

2007 ENGINE PERFORMANCE On-Board Diagnostic (MZI-3.5) - CX-9

	<ul style="list-style-type: none"> <li>• <b>Make sure the throttle body connector is properly connected.</b></li> <li>• Turn the ignition switch off.</li> <li>• Inspect the throttle actuator control motor for damaged housing, wiring harness connector, and wiring harness.</li> <li>• Are there any concerns with the throttle actuator control motor hardware?</li> </ul>	No	Go to the next step.
8	<b>INSPECT THROTTLE ACTUATOR CONTROL CIRCUITS FOR SHORT EACH OTHER</b> <ul style="list-style-type: none"> <li>• Turn the ignition switch off.</li> <li>• Measure resistance between throttle actuator terminal A and B.</li> <li>• Is the resistance more than 10 kilohms?</li> </ul>	Yes	Go to the next step.
		No	Repair or replace suspected part, then go to the next step.
9	<b>VERIFY TROUBLESHOOTING OF DTC P2112 HAS BEEN COMPLETED</b> <ul style="list-style-type: none"> <li>• Verify that all disconnected connectors reconnected.</li> <li>• Clear the DTC from the PCM memory using the M-MDS.</li> <li>• Perform the "KOEO or KOER self-test" using the M-MDS.</li> </ul> <p>(See <b><u>KOEO/KOER SELF TEST [MZI-3.5].</u></b>)</p> <ul style="list-style-type: none"> <li>• Is the PENDING CODE for the DTC present?</li> </ul>	Yes	Replace the PCM, then go to the next step. (see <b><u>PCM REMOVAL/INSTALLATION [MZI-3.5]</u></b> .)
		No	Go to the next step.
10	<b>VERIFY AFTER REPAIR PROCEDURE</b> <ul style="list-style-type: none"> <li>• Perform the "AFTER REPAIR PROCEDURE".</li> </ul> <p>(See <b><u>AFTER REPAIR PROCEDURE [MZI-3.5].</u></b>)</p>	Yes	Go to the applicable DTC inspection. (See <b><u>DTC TABLE [MZI-3.5].</u></b> )
		No	Troubleshooting completed.

## 2007 Mazda CX-9 Grand Touring

2007 ENGINE PERFORMANCE On-Board Diagnostic (MZI-3.5) - CX-9

- Are any DTCs present?

### DTC P2121, P2126, P2131 [MZI-3.5]

#### DTC P2121, P2126, P2131 (MZI-3.5) DETECTION CONDITION AND POSSIBLE CAUSES

<b>DTC P2121</b>	<b>APP sensor No.1 circuit range/performance</b>
<b>DTC P2126</b>	<b>APP sensor No.2 circuit range/performance</b>
<b>DTC P2131</b>	<b>APP sensor No.3 circuit range/performance</b>
<b>DETECTION CONDITION</b>	<ul style="list-style-type: none"><li>• APP sensor fault flag is set for sensor No.1, No.2 and No.3 by the PCM, indicating signal is out of the normal self-test operating range.</li></ul>
<b>POSSIBLE CAUSE</b>	<ul style="list-style-type: none"><li>• APP sensor signal circuits are shorted each other</li><li>• APP sensor malfunction</li><li>• PCM malfunction</li></ul> <p><b>P2121</b></p> <ul style="list-style-type: none"><li>○ Open circuit wiring harness between APP sensor terminal E and PCM terminal 1 AK</li><li>○ Short to ground circuit between APP sensor terminal E and PCM terminal 1</li><li>○ Short to power supply in wiring harness between APP sensor terminal E and PCM terminal 1 AK</li></ul> <p><b>P2126</b></p> <ul style="list-style-type: none"><li>○ Open circuit wiring harness between APP sensor terminal H and PCM terminal 1 AG</li><li>○ Short to ground circuit between APP sensor terminal H and PCM terminal 1</li><li>○ Short to power supply in wiring harness between APP sensor terminal H and PCM terminal 1 AG</li></ul> <p><b>P2131</b></p> <ul style="list-style-type: none"><li>○ Open circuit wiring harness between APP sensor terminal B and PCM terminal 1 AC</li><li>○ Short to ground circuit between APP sensor terminal B and PCM terminal 1</li><li>○ Short to power supply in wiring harness between APP sensor terminal B and PCM terminal 1 AC</li></ul>

## 2007 Mazda CX-9 Grand Touring

2007 ENGINE PERFORMANCE On-Board Diagnostic (MZI-3.5) - CX-9

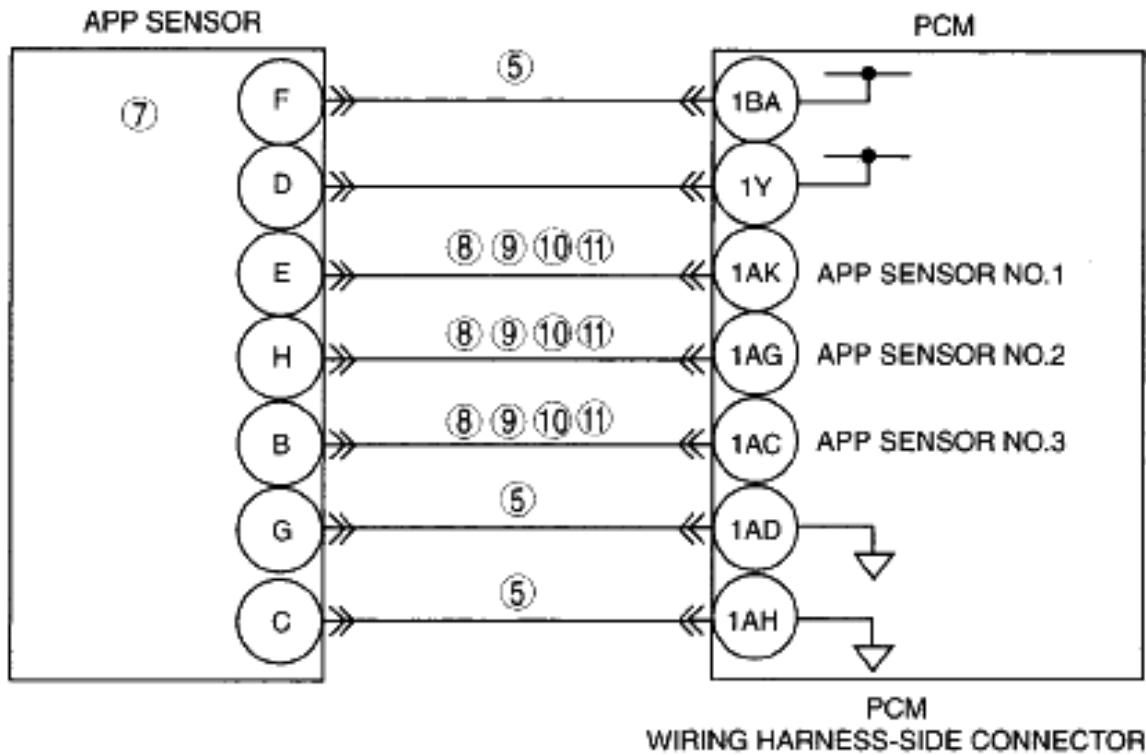

APP SENSOR  
WIRING HARNESS-SIDE CONNECTOR

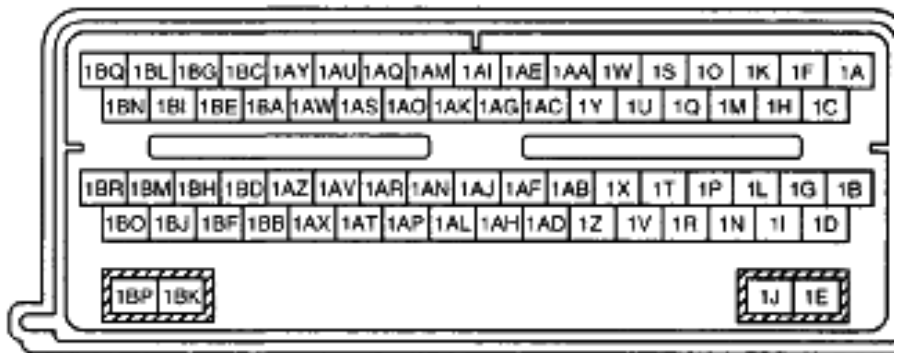
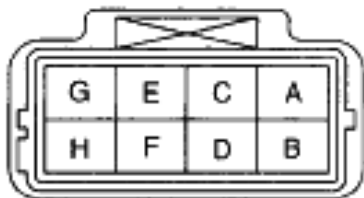

### DIAGNOSTIC PROCEDURE

#### DTC P2121, P2126, P2131 (MZI-3.5) DIAGNOSTIC PROCEDURE

STEP	INSPECTION		ACTION
1	<b>VERIFY FREEZE FRAME DATA HAS BEEN RECORDED</b>	Yes	Go to the next step.
		No	Record FREEZE FRAME DATA on the repair order, then go to the next step.
	<ul style="list-style-type: none"> <li>Has FREEZE FRAME DATA</li> </ul>		

## 2007 Mazda CX-9 Grand Touring

2007 ENGINE PERFORMANCE On-Board Diagnostic (MZI-3.5) - CX-9

	been recorded?		
2	<b>VERIFY RELATED REPAIR INFORMATION AVAILABILITY</b> <ul style="list-style-type: none"> <li>• Verify related Service Bulletins and/or on-line repair information availability.</li> <li>• Is any related Service Bulletins available?</li> </ul>	Yes	Perform repair or diagnosis according to the available Service Bulletins. <ul style="list-style-type: none"> <li>• If the vehicle is not repaired, go to the next step.</li> </ul>
		No	Go to the next step.
3	<b>INSPECT ACCELERATOR PEDAL FOR OBSTRUCTION</b> <ul style="list-style-type: none"> <li>• Turn the ignition switch to the ON position (Engine off).</li> <li>• Depress the accelerator pedal fully to the floor and release.</li> <li>• Does the pedal move freely to the floor and back?</li> </ul>	Yes	Go to the next step.
		No	Isolate and repair the obstruction. Then go to Step 12.
4	<b>INSPECT APP SENSOR SIGNAL VOLTAGE RANGES FOR ACCELERATOR PEDAL FULLY APPLIED AND DEPRESS POSITIONS</b> <ul style="list-style-type: none"> <li>• Access the PCM and monitor the APP1, APP2 and APP3 PIDs.</li> <li>• Verify the following values of the PIDs when depressing the accelerator pedal fully to the floor.                             <ul style="list-style-type: none"> <li>○ APP1: 0.48-1.79 V</li> <li>○ APP2: 2.95-4.62 V</li> <li>○ APP3: 2.43-4.02 V</li> </ul> </li> <li>• Verify the following values of the PIDs when press the accelerator pedal release.                             <ul style="list-style-type: none"> <li>○ APP1: 3.43-4.69 V</li> <li>○ APP2: 1.13-1.88 V</li> <li>○ APP3: 0.64-1.28 V</li> </ul> </li> <li>• Are all PIDs signals out of range for the pedal fully depressing and released positions?</li> </ul>	Yes	Go to the next step.
		No	Go to Step 6.
5	<b>INSPECT REFERENCE VOLTAGE TO APP SENSOR</b>	Yes	Go to the next step.

## 2007 Mazda CX-9 Grand Touring

2007 ENGINE PERFORMANCE On-Board Diagnostic (MZI-3.5) - CX-9

	<ul style="list-style-type: none"> <li>• Turn the ignition switch off.</li> <li>• Disconnect the APP sensor connector.</li> <li>• Turn the ignition switch to the ON position (Engine off).</li> <li>• Measure the voltage between the APP sensor connector D or F terminal (wiring harness side) and the APP sensor connector C or G terminal (wiring harness side)</li> <li>• Is the voltage between 4-6 V?</li> </ul>	No	Repair if necessary. Then go to Step 12.
6	<p><b>INSPECT FUNCTIONALITY OF APP CIRCUITS</b></p> <p><b>NOTE:</b></p> <ul style="list-style-type: none"> <li>• Use the voltage measurements from Step 4.</li> <li>• Are APP1, APP2 or APP3 out of range?</li> </ul>	Yes	Go to the next Step.
		No	Go to Step 11.
7	<p><b>INSPECT FUNCTIONALITY OF APP SENSOR</b></p> <ul style="list-style-type: none"> <li>• Turn the ignition switch off.</li> <li>• Disconnect the APP sensor connector.</li> <li>• Measure the resistance between the following APP sensor terminals (APP sensor component side).                             <ul style="list-style-type: none"> <li>○ E and D or F: 600-1,370 ohms</li> <li>○ E and C or G: 720-1,660 ohms</li> <li>○ E and H: 1,300-2,960 ohms</li> <li>○ E and B: 1,250-2,860 ohms</li> <li>○ H and D or F: 750-1,720 ohms</li> <li>○ H and C or G: 660-1,520 ohms</li> <li>○ H and B: 1,230-2,810 ohms</li> <li>○ B and D or F: 710-1,640</li> </ul> </li> </ul>	Yes	Go to next Step.
		No	Replace the accelerator pedal. Then go to Step 12.

## 2007 Mazda CX-9 Grand Touring

2007 ENGINE PERFORMANCE On-Board Diagnostic (MZI-3.5) - CX-9

	<p>ohms</p> <ul style="list-style-type: none"> <li>○ B and C or G: 580-1,340 ohms</li> <li>○ D or F and C or G: 200-470 ohms</li> </ul> <ul style="list-style-type: none"> <li>● Are all the resistances within specifications?</li> </ul>		
8	<p><b>INSPECT APP SENSOR SIGNAL CIRCUIT FOR OPEN CIRCUIT</b></p> <ul style="list-style-type: none"> <li>● Disconnect the PCM connector.</li> <li>● Inspect for continuity between the following terminals:                             <ul style="list-style-type: none"> <li>○ P2121:                                     <p style="margin-left: 20px;">APP sensor terminal E and PCM terminal 1AK</p> </li> <li>○ P2126:                                     <p style="margin-left: 20px;">APP sensor terminal H and PCM terminal 1AG</p> </li> <li>○ P2131:                                     <p style="margin-left: 20px;">APP sensor terminal B and PCM terminal 1AC</p> </li> </ul> </li> </ul> <ul style="list-style-type: none"> <li>● Are there continuity?</li> </ul>	Yes	Go to the next step.
		No	Repair or replace suspected part, then go to Step 12.
9	<p><b>INSPECT APP SENSOR SIGNAL CIRCUIT FOR SHORT TO GROUND</b></p> <ul style="list-style-type: none"> <li>● Turn the ignition switch off.</li> <li>● Inspect for continuity between the following terminals:                             <ul style="list-style-type: none"> <li>○ P2121:                                     <p style="margin-left: 20px;">APP sensor terminal E and body ground</p> </li> <li>○ P2126:                                     <p style="margin-left: 20px;">APP sensor terminal H and</p> </li> </ul> </li> </ul>	Yes	Repair or replace suspected part, then go to Step 12.
		No	Go to the next Step.



## 2007 Mazda CX-9 Grand Touring

2007 ENGINE PERFORMANCE On-Board Diagnostic (MZI-3.5) - CX-9

	<p>body ground</p> <ul style="list-style-type: none"> <li>○ P2131:</li> </ul> <p>APP sensor terminal B and body ground</p> <ul style="list-style-type: none"> <li>○ Are there continuity?</li> </ul>		
10	<p><b>INSPECT APP SENSOR SIGNAL CIRCUIT FOR SHORT TO POWER SUPPLY</b></p> <ul style="list-style-type: none"> <li>• Turn the ignition switch to the ON position (Engine off).</li> <li>• Measure the voltage between the following terminals:                             <ul style="list-style-type: none"> <li>○ P2121:</li> </ul> <p>APP sensor terminal E and body ground</p> <li>○ P2126:</li> </li></ul> <p>APP sensor terminal H and body ground</p> <ul style="list-style-type: none"> <li>○ P2131:</li> </ul> <p>APP sensor terminal B and body ground</p> <ul style="list-style-type: none"> <li>○ Are the voltage B+?</li> </ul>	Yes	Repair or replace suspected part, then go to Step 12.
		No	Go to the next Step.
11	<p><b>INSPECT APP SENSOR SIGNAL CIRCUIT FOR SHORT EACH OTHER</b></p> <ul style="list-style-type: none"> <li>• Turn the ignition switch off.</li> <li>• Disconnect PCM connector.</li> <li>• Disconnect APP sensor connector.</li> <li>• Measure the resistance between the following APP sensor terminals (wiring harness-side)                             <ul style="list-style-type: none"> <li>○ P2121</li> </ul> <p>E and H</p> </li> </ul>	Yes	Go to the next step.

## 2007 Mazda CX-9 Grand Touring

2007 ENGINE PERFORMANCE On-Board Diagnostic (MZI-3.5) - CX-9

	<p>E and B</p> <p>E and D or F</p> <p>E and C or G</p> <p>○ P2126</p> <p>H and E</p> <p>H and B</p> <p>H and D or F</p> <p>H and C or G</p> <p>○ P2131</p> <p>B and E</p> <p>B and H</p> <p>B and D or F</p> <p>B and C or G</p> <p>○ Are there resistance greater than 10 kilohms?</p>	No	Repair or replace suspected part, then go to the next step.
12	<p><b>VERIFY TROUBLESHOOTING OF DTC P2121, P2126 or P2131 HAS BEEN COMPLETED</b></p> <ul style="list-style-type: none"> <li>• Verify that all disconnected connectors reconnected.</li> <li>• Clear the DTC from the PCM memory using the M-MDS.</li> <li>• Perform the KOEO or KOER self-test using the M-MDS.</li> </ul> <p>(See <b><u>KOEO/KOER SELF TEST [MZI-3.5].</u></b>)</p> <ul style="list-style-type: none"> <li>• Is the PENDING CODE for the DTC present?</li> </ul>	Yes	Replace the PCM, then go to the next step. (see <b><u>PCM REMOVAL/INSTALLATION [MZI-3.5]</u></b> .)
		No	Go to the next step.
13	<p><b>VERIFY AFTER REPAIR PROCEDURE</b></p>	Yes	Go to the applicable DTC inspection. (See <b><u>DTC TABLE [MZI-3.5].</u></b> )

## 2007 Mazda CX-9 Grand Touring

2007 ENGINE PERFORMANCE On-Board Diagnostic (MZI-3.5) - CX-9

<ul style="list-style-type: none"><li>• Perform "AFTER REPAIR PROCEDURE".</li></ul> <p>(See <b><u>AFTER REPAIR PROCEDURE [MZI-3.5].</u></b>)</p> <ul style="list-style-type: none"><li>• Are any DTCs present?</li></ul>	No	Troubleshooting completed.
--	----	----------------------------

### DTC P2122 [MZI-3.5]

#### DTC P2122 (MZI-3.5) DETECTION CONDITION AND POSSIBLE CAUSES

<b>DTC P2122</b>	<b>APP sensor No.1 circuit low input</b>
<b>DETECTION CONDITION</b>	<ul style="list-style-type: none"><li>• APP sensor No.1 is out of self-test range low.</li></ul>
<b>POSSIBLE CAUSE</b>	<ul style="list-style-type: none"><li>• Short to ground circuit between APP sensor terminal F and PCM terminal 1BA</li><li>• Short to ground circuit between APP sensor terminal D and PCM terminal 1Y</li><li>• Short to ground circuit between APP sensor terminal G and PCM terminal 1AD</li><li>• Short to ground circuit between APP sensor terminal C and PCM terminal 1AH</li><li>• Short to ground circuit between APP sensor terminal E and PCM terminal 1AK</li><li>• Connector or terminal malfunction</li><li>• APP sensor malfunction</li></ul>

## 2007 Mazda CX-9 Grand Touring

2007 ENGINE PERFORMANCE On-Board Diagnostic (MZI-3.5) - CX-9

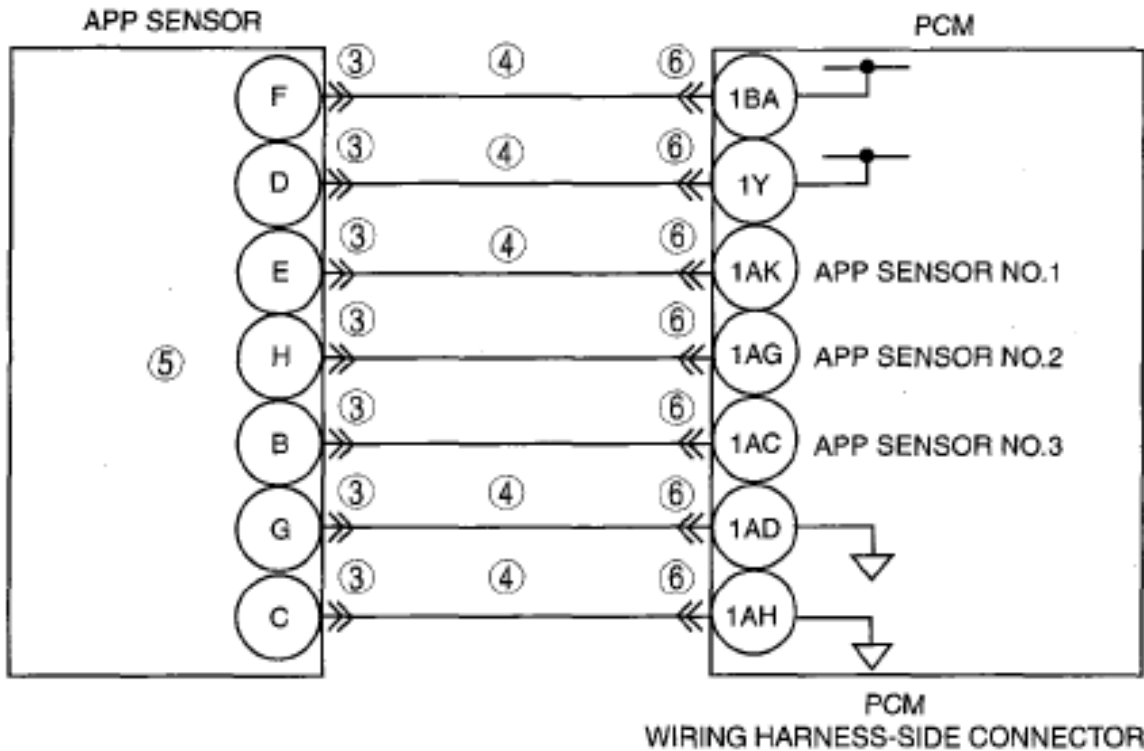

APP SENSOR  
WIRING HARNESS-SIDE CONNECTOR

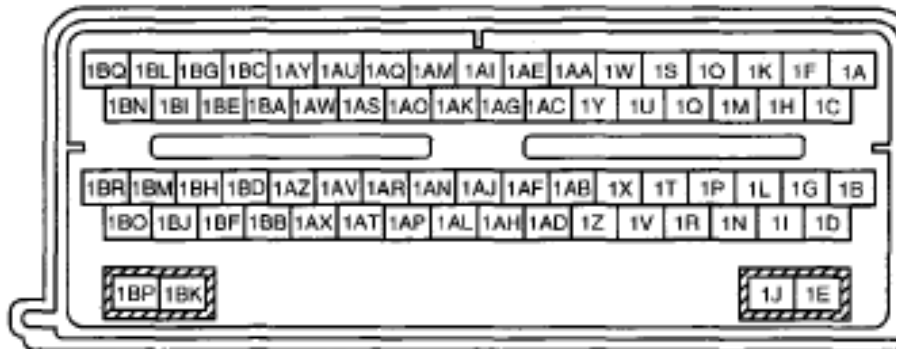
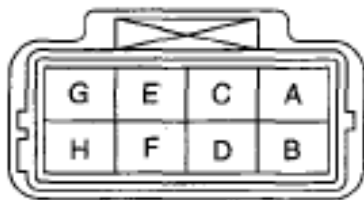

### DIAGNOSTIC PROCEDURE

#### DTC P2122 (MZI-3.5) DIAGNOSTIC PROCEDURE

STEP	INSPECTION		ACTION
1	<b>VERIFY FREEZE FRAME DATA HAS BEEN RECORDED</b> <ul style="list-style-type: none"> <li>• Has FREEZE FRAME DATA</li> </ul>	Yes	Go to the next step.
		No	Record FREEZE FRAME DATA on the repair order, then go to the next step.

## 2007 Mazda CX-9 Grand Touring

2007 ENGINE PERFORMANCE On-Board Diagnostic (MZI-3.5) - CX-9

	been recorded?		
2	<b>VERIFY RELATED REPAIR INFORMATION AVAILABILITY</b> <ul style="list-style-type: none"> <li>• Verify related Service Bulletins and/or on-line repair information availability.</li> <li>• Is any related Service Bulletins available?</li> </ul>	Yes	Perform repair or diagnosis according to the available Service Bulletins. <ul style="list-style-type: none"> <li>• If the vehicle is not repaired, go to the next step.</li> </ul>
		No	Go to the next step.
3	<b>INSPECT APP SENSOR CONNECTOR FOR POOR CONNECTION</b> <ul style="list-style-type: none"> <li>• Turn the ignition switch off.</li> <li>• Disconnect the APP sensor connector.</li> <li>• Inspect for poor connection (such as damaged/pulled-out pins, corrosion).</li> <li>• Is there any malfunction?</li> </ul>	Yes	Repair or replace suspected part, then go to Step 7.
		No	Go to the next step.
4	<b>INSPECT APP SENSOR NO.1 CIRCUIT FOR SHORT TO GROUND</b> <ul style="list-style-type: none"> <li>• Turn the ignition switch off.</li> <li>• Inspect for continuity between the following terminals:                             <ul style="list-style-type: none"> <li>○ APP sensor terminal F and body ground.</li> <li>○ APP sensor terminal D and body ground.</li> <li>○ APP sensor terminal G and body ground.</li> <li>○ APP sensor terminal C and body ground.</li> <li>○ APP sensor terminal E and body ground.</li> </ul> </li> <li>• Are there continuity?</li> </ul>	Yes	Repair or replace suspected part, then go to Step 7.
		No	Go to the next step.
5	<b>INSPECT APP SENSOR NO.1</b> <ul style="list-style-type: none"> <li>• Inspect APP sensor No.1.</li> </ul> (see <b><u>ACCELERATOR PEDAL</u></b>	Yes	Replace the accelerator pedal, then go to Step 7. (see <b><u>ACCELERATOR PEDAL REMOVAL/INSTALLATION [MZI-3.5]</u></b> .)

## 2007 Mazda CX-9 Grand Touring

2007 ENGINE PERFORMANCE On-Board Diagnostic (MZI-3.5) - CX-9

	<p><b><u>POSITION (APP) SENSOR INSPECTION [MZI-3.5].</u></b></p> <ul style="list-style-type: none"> <li>Is there any malfunction?</li> </ul>	No	Go to the next step.
6	<p><b>INSPECT PCM CONNECTOR FOR POOR CONNECTION</b></p> <ul style="list-style-type: none"> <li>Turn the ignition switch off.</li> <li>Disconnect the PCM connector.</li> <li>Inspect for poor connection (such as damaged/pulled-out pins, corrosion).</li> <li>Is there any malfunction?</li> </ul>	Yes	Repair or replace suspected part, then go to Step 7.
		No	Go to the next step.
7	<p><b>VERIFY TROUBLESHOOTING OF DTC P2122 HAS BEEN COMPLETED</b></p> <ul style="list-style-type: none"> <li>Verify that all disconnected connectors reconnected.</li> <li>Clear the DTC from the PCM memory using the M-MDS.</li> <li>Start the engine.</li> <li>Is the same DTC present?</li> </ul>	Yes	Replace the PCM, then go to the next step. (see <b><u>PCM REMOVAL/INSTALLATION [MZI-3.5].</u></b> )
		No	Go to the next step.
8	<p><b>VERIFY AFTER REPAIR PROCEDURE</b></p> <ul style="list-style-type: none"> <li>Perform the "AFTER REPAIR PROCEDURE".</li> </ul> <p>(See <b><u>AFTER REPAIR PROCEDURE [MZI-3.5].</u></b>)</p> <ul style="list-style-type: none"> <li>Are any DTC present?</li> </ul>	Yes	Go to the applicable DTC inspection. (See <b><u>DTC TABLE [MZI-3.5].</u></b> )
		No	DTC troubleshooting completed.

### DTC P2123 [MZI-3.5]

#### DTC P2123 (MZI-3.5) DETECTION CONDITION AND POSSIBLE CAUSES

<b>DTC P2123</b>	<b>APP sensor No.1 circuit high input</b>
<b>DETECTION CONDITION</b>	<ul style="list-style-type: none"> <li>APP sensor No.1 is out of self-test range high.</li> </ul>
	<ul style="list-style-type: none"> <li>Open circuit wiring harness between APP sensor terminal F and PCM terminal 1E</li> <li>Open circuit wiring harness between APP sensor terminal D and PCM terminal 1'</li> <li>Open circuit wiring harness between APP sensor terminal G and PCM terminal 1,</li> </ul>

## 2007 Mazda CX-9 Grand Touring

2007 ENGINE PERFORMANCE On-Board Diagnostic (MZI-3.5) - CX-9

### POSSIBLE CAUSE

- Open circuit wiring harness between APP sensor terminal C and PCM terminal 1J
- Open circuit wiring harness between APP sensor terminal E and PCM terminal 1J
- Short to power supply in wiring harness between APP sensor terminal F and PCM terminal 1BA
- Short to power supply in wiring harness between APP sensor terminal D and PCM terminal 1Y
- Short to power supply in wiring harness between APP sensor terminal G and PCM terminal 1AD
- Short to power supply in wiring harness between APP sensor terminal C and PCM terminal 1AH
- Short to power supply in wiring harness between APP sensor terminal E and PCM terminal 1AK
- Connector or terminal malfunction
- APP sensor malfunction

## 2007 Mazda CX-9 Grand Touring

2007 ENGINE PERFORMANCE On-Board Diagnostic (MZI-3.5) - CX-9

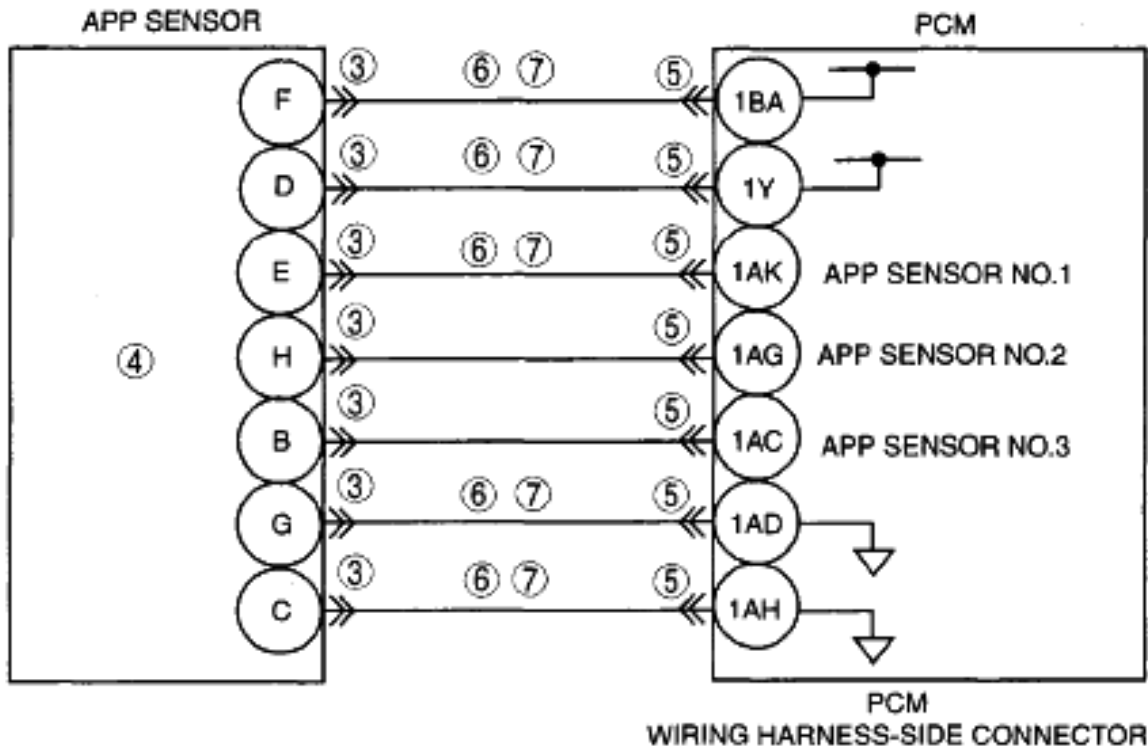

APP SENSOR  
WIRING HARNESS-SIDE CONNECTOR

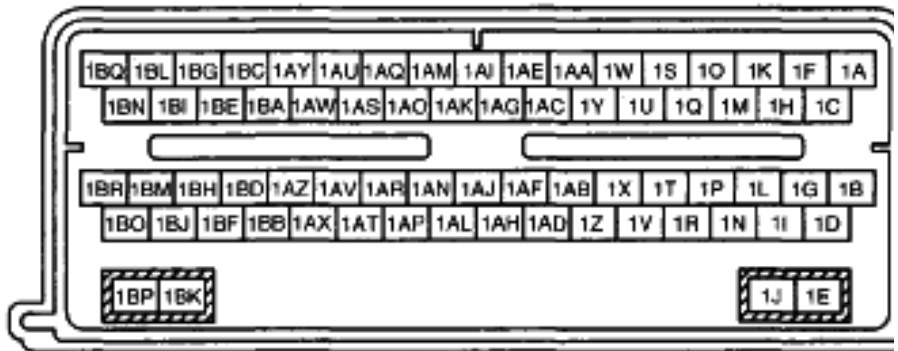

### DIAGNOSTIC PROCEDURE

#### DTC P2123 (MZI-3.5) DIAGNOSTIC PROCEDURE

STEP	INSPECTION	ACTION	
1	<b>VERIFY FREEZE FRAME DATA HAS BEEN RECORDED</b>	Yes	Go to the next step.
		No	Record FREEZE FRAME DATA on the repair order, then go to the next step.
	<ul style="list-style-type: none"> <li>Has FREEZE FRAME DATA</li> </ul>		



## 2007 Mazda CX-9 Grand Touring

2007 ENGINE PERFORMANCE On-Board Diagnostic (MZI-3.5) - CX-9

	been recorded?		
2	<b>VERIFY RELATED REPAIR INFORMATION AVAILABILITY</b> <ul style="list-style-type: none"> <li>• Verify related Service Bulletins and/or on-line repair information availability.</li> <li>• Is any related Service Bulletins available?</li> </ul>	Yes	Perform repair or diagnosis according to the available Service Bulletins. <ul style="list-style-type: none"> <li>• If the vehicle is not repaired, go to the next step.</li> </ul>
		No	Go to the next step.
3	<b>INSPECT APP SENSOR CONNECTOR FOR POOR CONNECTION</b> <ul style="list-style-type: none"> <li>• Turn the ignition switch off.</li> <li>• Disconnect the APP sensor connector.</li> <li>• Inspect for poor connection (such as damaged/pulled-out pins, corrosion).</li> <li>• Are there any malfunction?</li> </ul>	Yes	Repair or replace suspected part, then go to Step 8.
		No	Go to the next step.
4	<b>INSPECT APP SENSOR NO.1</b> <ul style="list-style-type: none"> <li>• Inspect APP sensor No.1.</li> </ul> (see <b><u>ACCELERATOR PEDAL POSITION (APP) SENSOR INSPECTION [MZI-3.5].</u></b> )	Yes	Replace the accelerator pedal, then go to Step 8. (see <b><u>ACCELERATOR PEDAL REMOVAL/INSTALLATION [MZI-3.5].</u></b> )
		No	Go to the next step.
5	<b>INSPECT PCM CONNECTOR FOR POOR CONNECTION</b> <ul style="list-style-type: none"> <li>• Turn the ignition switch off.</li> <li>• Disconnect the PCM connector.</li> <li>• Inspect for poor connection (such as damaged/pulled-out pins, corrosion).</li> <li>• Is there any malfunction?</li> </ul>	Yes	Repair or replace suspected part, then go to Step 8.
		No	Go to the next step.
6	<b>INSPECT APP SENSOR NO.1 CIRCUIT FOR OPEN CIRCUIT</b> <ul style="list-style-type: none"> <li>• Turn the ignition switch off.</li> <li>• Inspect for continuity between the following terminals (wiring</li> </ul>	Yes	Go to the next step.

## 2007 Mazda CX-9 Grand Touring

2007 ENGINE PERFORMANCE On-Board Diagnostic (MZI-3.5) - CX-9

	<p>harness-side).</p> <ul style="list-style-type: none"> <li>○ APP sensor terminal F and PCM terminal 1BA.</li> <li>○ APP sensor terminal D and PCM terminal 1Y.</li> <li>○ APP sensor terminal G and PCM terminal 1AD.</li> <li>○ APP sensor terminal C and PCM terminal 1AH.</li> <li>○ APP sensor terminal E and PCM terminal 1AK.</li> </ul> <ul style="list-style-type: none"> <li>● Are there continuity?</li> </ul>	No	Repair or replace suspected part, then go to Step 8.
7	<p><b>INSPECT APP SENSOR NO.1 SIGNAL CIRCUIT FOR SHORT TO POWER SUPPLY</b></p> <ul style="list-style-type: none"> <li>● Turn the ignition switch to the ON position (Engine off).</li> <li>● Measure the voltage between the following terminals (wiring harness-side).                             <ul style="list-style-type: none"> <li>○ APP sensor terminal F and body ground.</li> <li>○ APP sensor terminal D and body ground.</li> <li>○ APP sensor terminal G and body ground.</li> <li>○ APP sensor terminal C and body ground.</li> <li>○ APP sensor terminal E and body ground.</li> </ul> </li> <li>● Are there voltage <b>B+</b> ?</li> </ul>	Yes	Repair or replace suspected part, then go to Step 8.
		No	Go to the next step.
8	<p><b>VERIFY TROUBLESHOOTING OF DTC P2123 HAS BEEN COMPLETED</b></p> <ul style="list-style-type: none"> <li>● Verify that all disconnected connectors reconnected.</li> <li>● Clear the DTC from the PCM memory using the M-MDS.</li> <li>● Start the engine.</li> <li>● Is the same DTC present?</li> </ul>	Yes	Replace the PCM, then go to the next step. (see <b><u>PCM REMOVAL/INSTALLATION [MZI-3.5]</u></b> .)
		No	Go to the next step.

## 2007 Mazda CX-9 Grand Touring

2007 ENGINE PERFORMANCE On-Board Diagnostic (MZI-3.5) - CX-9

9	<b>VERIFY AFTER REPAIR PROCEDURE</b> <ul style="list-style-type: none"> <li>• Perform the "AFTER REPAIR PROCEDURE".</li> </ul> <p>(See <b><u>AFTER REPAIR PROCEDURE [MZI-3.5].</u></b>)</p> <ul style="list-style-type: none"> <li>• Are any DTC present?</li> </ul>	Yes	Go to the applicable DTC inspection. (See <b><u>DTC TABLE [MZI-3.5].</u></b> )
		No	DTC troubleshooting completed.

### DTC P2127 [MZI-3.5]

#### DTC P2127 (MZI-3.5) DETECTION CONDITION AND POSSIBLE CAUSES

<b>DTC P2127</b>	<b>APP sensor No.2 circuit low input</b>
<b>DETECTION CONDITION</b>	<ul style="list-style-type: none"> <li>• APP sensor No.2 is out of self-test range low.</li> </ul>
<b>POSSIBLE CAUSE</b>	<ul style="list-style-type: none"> <li>• Short to ground circuit between APP sensor terminal F and PCM terminal 1BA</li> <li>• Short to ground circuit between APP sensor terminal D and PCM terminal 1Y</li> <li>• Short to ground circuit between APP sensor terminal G and PCM terminal 1AD</li> <li>• Short to ground circuit between APP sensor terminal C and PCM terminal 1AH</li> <li>• Short to ground circuit between APP sensor terminal H and PCM terminal 1AG</li> <li>• Connector or terminal malfunction</li> <li>• APP sensor malfunction</li> </ul>

## 2007 Mazda CX-9 Grand Touring

2007 ENGINE PERFORMANCE On-Board Diagnostic (MZI-3.5) - CX-9

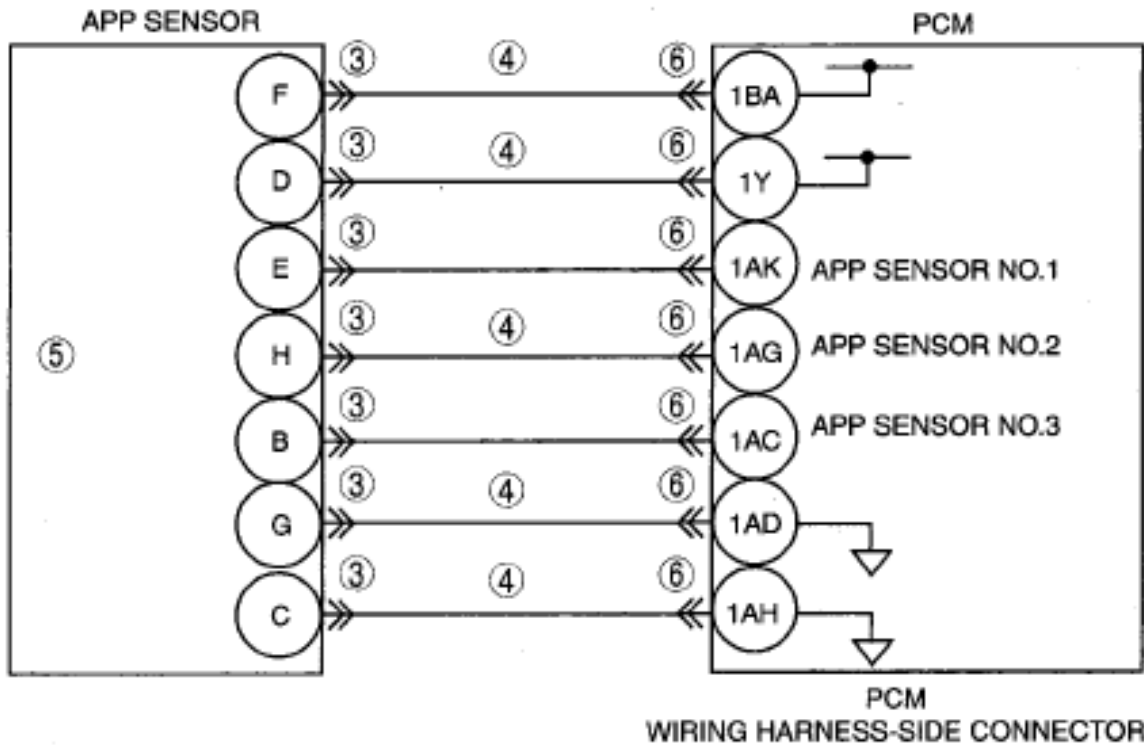

APP SENSOR  
WIRING HARNESS-SIDE CONNECTOR

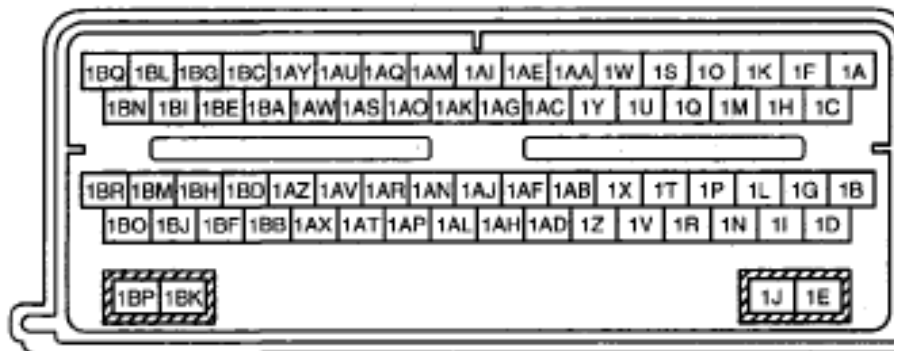
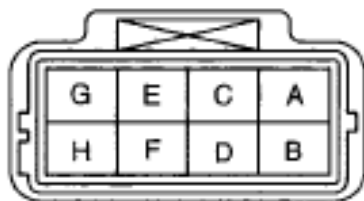

### DIAGNOSTIC PROCEDURE

#### DTC P2127 (MZI-3.5) DIAGNOSTIC PROCEDURE

STEP	INSPECTION		ACTION
1	<b>VERIFY FREEZE FRAME DATA HAS BEEN RECORDED</b> <ul style="list-style-type: none"> <li>Has FREEZE FRAME DATA</li> </ul>	Yes	Go to the next step.
		No	Record FREEZE FRAME DATA on the repair order, then go to the next step.

## 2007 Mazda CX-9 Grand Touring

2007 ENGINE PERFORMANCE On-Board Diagnostic (MZI-3.5) - CX-9

	been recorded?		
2	<b>VERIFY RELATED REPAIR INFORMATION AVAILABILITY</b> <ul style="list-style-type: none"> <li>• Verify related Service Bulletins and/or on-line repair information availability.</li> <li>• Is any related Service Bulletins available?</li> </ul>	Yes	Perform repair or diagnosis according to the available Service Bulletins. <ul style="list-style-type: none"> <li>• If the vehicle is not repaired, go to the next step.</li> </ul>
		No	Go to the next step.
3	<b>INSPECT APP SENSOR CONNECTOR FOR POOR CONNECTION</b> <ul style="list-style-type: none"> <li>• Turn the ignition switch off.</li> <li>• Disconnect the APP sensor connector.</li> <li>• Inspect for poor connection (such as damaged/pulled-out pins, corrosion).</li> <li>• Are there any malfunction?</li> </ul>	Yes	Repair or replace suspected part, then go to Step 7.
		No	Go to the next step.
4	<b>INSPECT APP SENSOR NO.2 CIRCUIT FOR SHORT TO GROUND</b> <ul style="list-style-type: none"> <li>• Turn the ignition switch off.</li> <li>• Inspect for continuity between the following terminals:                             <ul style="list-style-type: none"> <li>○ APP sensor terminal F and body ground.</li> <li>○ APP sensor terminal D and body ground.</li> <li>○ APP sensor terminal G and body ground.</li> <li>○ APP sensor terminal C and body ground.</li> <li>○ APP sensor terminal H and body ground.</li> </ul> </li> <li>• Are there continuity?</li> </ul>	Yes	Repair or replace suspected part, then go to Step 7.
		No	Go to the next step.
5	<b>INSPECT APP SENSOR NO.2</b> <ul style="list-style-type: none"> <li>• Inspect APP sensor No.2.</li> </ul> (see <b><u>ACCELERATOR PEDAL</u></b>	Yes	Replace the accelerator pedal, then go to Step 7. (see <b><u>ACCELERATOR PEDAL REMOVAL/INSTALLATION [MZI-3.5]</u></b> .)

## 2007 Mazda CX-9 Grand Touring

2007 ENGINE PERFORMANCE On-Board Diagnostic (MZI-3.5) - CX-9

	<p><b><u>POSITION (APP) SENSOR INSPECTION [MZI-3.5].</u></b></p> <ul style="list-style-type: none"> <li>• Is there any malfunction?</li> </ul>	No	Go to the next step.
6	<p><b>INSPECT PCM CONNECTOR FOR POOR CONNECTION</b></p> <ul style="list-style-type: none"> <li>• Turn the ignition switch off.</li> <li>• Disconnect the PCM connector.</li> <li>• Inspect for poor connection (such as damaged/pulled-out pins, corrosion).</li> <li>• Are there any malfunction?</li> </ul>	Yes	Repair or replace suspected part, then go to Step 7.
		No	Go to the next step.
7	<p><b>VERIFY TROUBLESHOOTING OF DTC P2127 HAS BEEN COMPLETED</b></p> <ul style="list-style-type: none"> <li>• Verify that all disconnected connectors reconnected.</li> <li>• Clear the DTC from the PCM memory using the M-MDS.</li> <li>• Start the engine.</li> <li>• Is the same DTC present?</li> </ul>	Yes	Replace the PCM, then go to the next step. (see <b><u>PCM REMOVAL/INSTALLATION [MZI-3.5].</u></b> )
		No	Go to the next step.
8	<p><b>VERIFY AFTER REPAIR PROCEDURE</b></p> <ul style="list-style-type: none"> <li>• Perform the "AFTER REPAIR PROCEDURE".</li> </ul> <p>(See <b><u>AFTER REPAIR PROCEDURE [MZI-3.5].</u></b>)</p> <ul style="list-style-type: none"> <li>• Are any DTC present?</li> </ul>	Yes	Go to the applicable DTC inspection. (See <b><u>DTC TABLE [MZI-3.5].</u></b> )
		No	DTC troubleshooting completed.

### DTC P2128 [MZI-3.5]

#### DTC P2128 (MZI-3.5) DETECTION CONDITION AND POSSIBLE CAUSES

<b>DTC P2128</b>	<b>APP sensor No.2 circuit high input</b>
<b>DETECTION CONDITION</b>	<ul style="list-style-type: none"> <li>• APP sensor No.2 is out of self-test range high.</li> </ul>
	<ul style="list-style-type: none"> <li>• Open circuit wiring harness between APP sensor terminal F and PCM terminal 1E</li> <li>• Open circuit wiring harness between APP sensor terminal D and PCM terminal 1'</li> <li>• Open circuit wiring harness between APP sensor terminal G and PCM terminal 1,</li> </ul>

## 2007 Mazda CX-9 Grand Touring

2007 ENGINE PERFORMANCE On-Board Diagnostic (MZI-3.5) - CX-9

### POSSIBLE CAUSE

- Open circuit wiring harness between APP sensor terminal C and PCM terminal 1Z
- Open circuit wiring harness between APP sensor terminal H and PCM terminal 1Z
- Short to power supply in wiring harness between APP sensor terminal F and PCM terminal 1BA
- Short to power supply in wiring harness between APP sensor terminal D and PCM terminal 1Y
- Short to power supply in wiring harness between APP sensor terminal G and PCM terminal 1AD
- Short to power supply in wiring harness between APP sensor terminal C and PCM terminal 1AH
- Short to power supply in wiring harness between APP sensor terminal H and PCM terminal 1AG
- Connector or terminal malfunction
- APP sensor malfunction

# 2007 Mazda CX-9 Grand Touring

2007 ENGINE PERFORMANCE On-Board Diagnostic (MZI-3.5) - CX-9

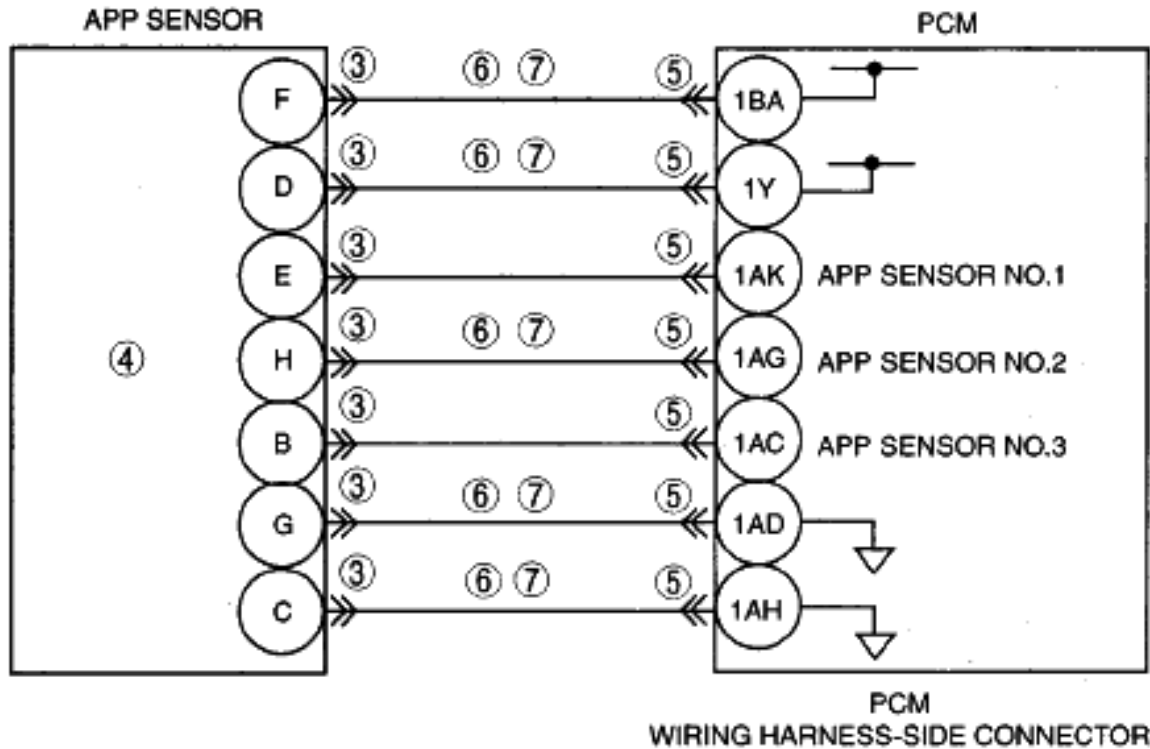

**APP SENSOR WIRING HARNESS-SIDE CONNECTOR**

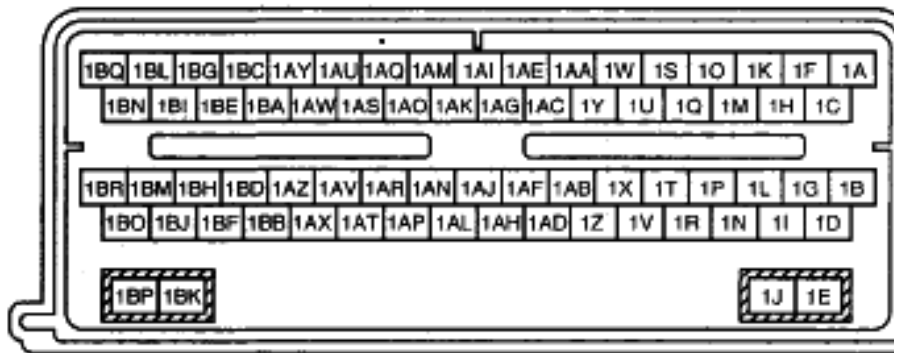
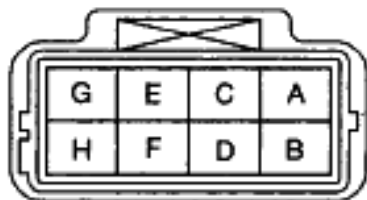

## DIAGNOSTIC PROCEDURE

### DTC P2128 (MZI-3.5) DIAGNOSTIC PROCEDURE

STEP	INSPECTION		ACTION
1	<b>VERIFY FREEZE FRAME DATA HAS BEEN RECORDED</b>	Yes	Go to the next step.
		No	Record FREEZE FRAME DATA on the repair order, then go to the next step.
	<ul style="list-style-type: none"> <li>Has FREEZE FRAME DATA</li> </ul>		



## 2007 Mazda CX-9 Grand Touring

2007 ENGINE PERFORMANCE On-Board Diagnostic (MZI-3.5) - CX-9

	been recorded?		
2	<b>VERIFY RELATED REPAIR INFORMATION AVAILABILITY</b> <ul style="list-style-type: none"> <li>• Verify related Service Bulletins and/or on-line repair information availability.</li> <li>• Is any related Service Bulletins available?</li> </ul>	Yes	Perform repair or diagnosis according to the available Service Bulletins. <ul style="list-style-type: none"> <li>• If the vehicle is not repaired, go to the next step.</li> </ul>
		No	Go to the next step.
3	<b>INSPECT APP SENSOR CONNECTOR FOR POOR CONNECTION</b> <ul style="list-style-type: none"> <li>• Turn the ignition switch off.</li> <li>• Disconnect the APP sensor connector.</li> <li>• Inspect for poor connection (such as damaged/pulled-out pins, corrosion).</li> <li>• Are there any malfunction?</li> </ul>	Yes	Repair or replace suspected part, then go to Step 8.
		No	Go to the next step.
4	<b>INSPECT APP SENSOR NO.2</b> <ul style="list-style-type: none"> <li>• Inspect APP sensor No.2.</li> </ul> (see <b><u>ACCELERATOR PEDAL POSITION (APP) SENSOR INSPECTION [MZI-3.5].</u></b> )	Yes	Replace the accelerator pedal, then go to Step 8. (see <b><u>ACCELERATOR PEDAL REMOVAL/INSTALLATION [MZI-3.5].</u></b> )
		No	Go to the next step.
5	<b>INSPECT PCM CONNECTOR FOR POOR CONNECTION</b> <ul style="list-style-type: none"> <li>• Turn the ignition switch off.</li> <li>• Disconnect the PCM connector.</li> <li>• Inspect for poor connection (such as damaged/pulled-out pins, corrosion).</li> <li>• Are there any malfunction?</li> </ul>	Yes	Repair or replace suspected part, then go to Step 8.
		No	Go to the next step.
6	<b>INSPECT APP SENSOR NO.2 CIRCUIT FOR OPEN CIRCUIT</b> <ul style="list-style-type: none"> <li>• Turn the ignition switch off.</li> <li>• Inspect for continuity between the following terminals (wiring</li> </ul>	Yes	Go to the next step.

## 2007 Mazda CX-9 Grand Touring

2007 ENGINE PERFORMANCE On-Board Diagnostic (MZI-3.5) - CX-9

	<p>harness-side).</p> <ul style="list-style-type: none"> <li>○ APP sensor terminal F and PCM terminal 1BA.</li> <li>○ APP sensor terminal D and PCM terminal 1Y.</li> <li>○ APP sensor terminal G and PCM terminal 1AD.</li> <li>○ APP sensor terminal C and PCM terminal 1AH.</li> <li>○ APP sensor terminal H and PCM terminal 1AG.</li> </ul> <ul style="list-style-type: none"> <li>● Are there continuity?</li> </ul>	No	Repair or replace suspected part, then go to Step 8.
7	<p><b>INSPECT APP SENSOR NO.2 SIGNAL CIRCUIT FOR SHORT TO POWER SUPPLY</b></p> <ul style="list-style-type: none"> <li>● Turn the ignition switch to the ON position (Engine off).</li> <li>● Measure the voltage between the following terminals (wiring harness-side). <ul style="list-style-type: none"> <li>○ APP sensor terminal F and body ground.</li> <li>○ APP sensor terminal D and body ground.</li> <li>○ APP sensor terminal G and body ground.</li> <li>○ APP sensor terminal C and body ground.</li> <li>○ APP sensor terminal H and body ground.</li> </ul> </li> <li>● Are there voltage <b>B+</b> ?</li> </ul>	Yes	Repair or replace suspected part, then go to Step 8.
		No	Go to the next step.
8	<p><b>VERIFY TROUBLESHOOTING OF DTC P2128 HAS BEEN COMPLETED</b></p> <ul style="list-style-type: none"> <li>● Verify that all disconnected connectors reconnected.</li> <li>● Clear the DTC from the PCM memory using the M-MDS.</li> <li>● Start the engine.</li> <li>● Is the same DTC present?</li> </ul>	Yes	Replace the PCM, then go to the next step. (see <b><u>PCM REMOVAL/INSTALLATION [MZI-3.5]</u></b> .)
		No	Go to the next step.

## 2007 Mazda CX-9 Grand Touring

2007 ENGINE PERFORMANCE On-Board Diagnostic (MZI-3.5) - CX-9

9	<b>VERIFY AFTER REPAIR PROCEDURE</b> <ul style="list-style-type: none"> <li>• Perform the "AFTER REPAIR PROCEDURE".</li> </ul> <p>(See <b><u>AFTER REPAIR PROCEDURE [MZI-3.5].</u></b>)</p> <ul style="list-style-type: none"> <li>• Are any DTC present?</li> </ul>	Yes	Go to the applicable DTC inspection. (See <b><u>DTC TABLE [MZI-3.5].</u></b> )
		No	DTC troubleshooting completed.

### DTC P2132 [MZI-3.5]

#### DTC P2132 (MZI-3.5) DETECTION CONDITION AND POSSIBLE CAUSES

<b>DTC P2132</b>	<b>APP sensor No.3 circuit low input</b>
<b>DETECTION CONDITION</b>	<ul style="list-style-type: none"> <li>• APP sensor No.3 is out of self-test range low.</li> </ul>
<b>POSSIBLE CAUSE</b>	<ul style="list-style-type: none"> <li>• Short to ground circuit between APP sensor terminal F and PCM terminal 1BA</li> <li>• Short to ground circuit between APP sensor terminal D and PCM terminal 1Y</li> <li>• Short to ground circuit between APP sensor terminal G and PCM terminal 1AD</li> <li>• Short to ground circuit between APP sensor terminal C and PCM terminal 1AH</li> <li>• Short to ground circuit between APP sensor terminal B and PCM terminal 1AC</li> <li>• Connector or terminal malfunction</li> <li>• APP sensor malfunction</li> </ul>

## 2007 Mazda CX-9 Grand Touring

2007 ENGINE PERFORMANCE On-Board Diagnostic (MZI-3.5) - CX-9

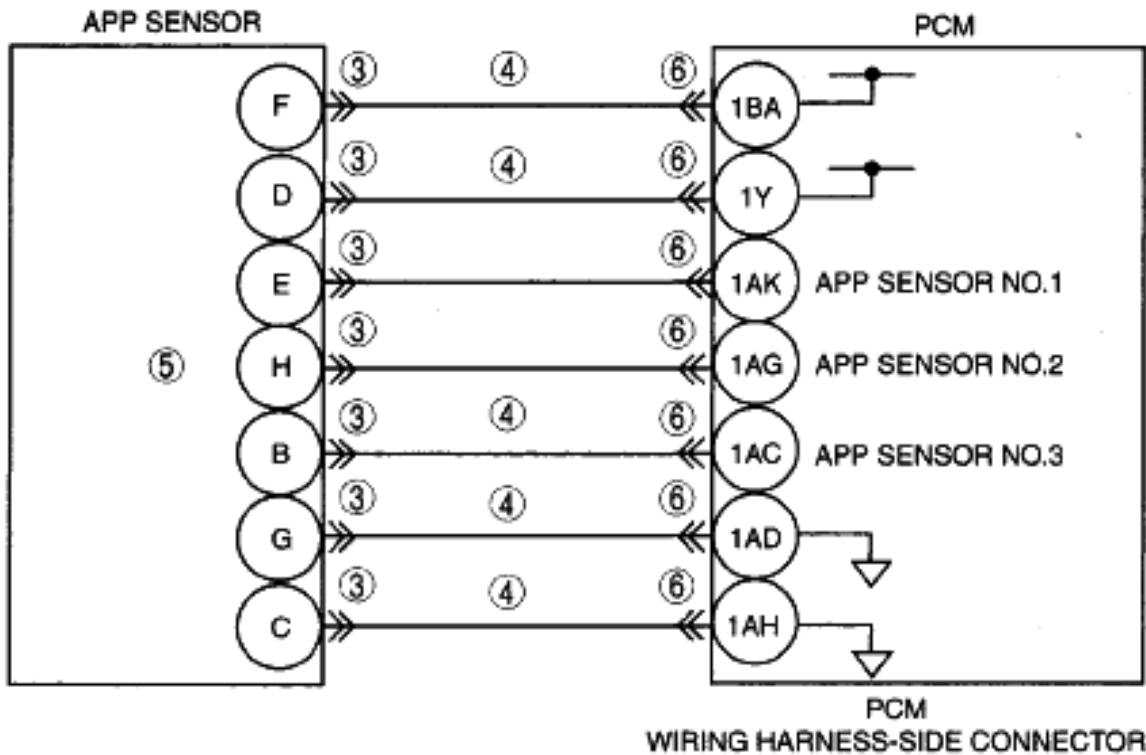

APP SENSOR  
WIRING HARNESS-SIDE CONNECTOR

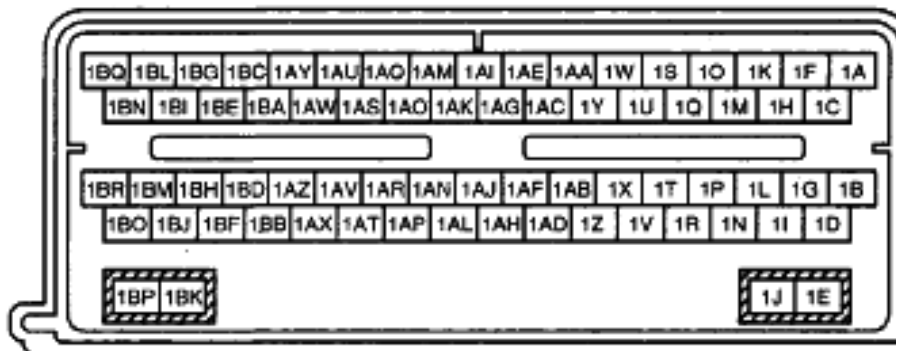
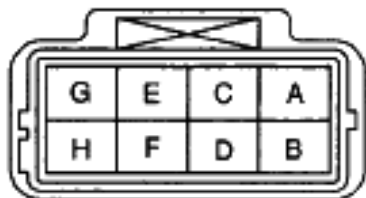

### DIAGNOSTIC PROCEDURE

#### DTC P2132 (MZI-3.5) DIAGNOSTIC PROCEDURE

STEP	INSPECTION		ACTION
1	<b>VERIFY FREEZE FRAME DATA HAS BEEN RECORDED</b>	Yes	Go to the next step.
		No	Record FREEZE FRAME DATA on the repair order, then go to the next step.
	<ul style="list-style-type: none"> <li>Has FREEZE FRAME DATA</li> </ul>		

## 2007 Mazda CX-9 Grand Touring

2007 ENGINE PERFORMANCE On-Board Diagnostic (MZI-3.5) - CX-9

	been recorded?		
2	<b>VERIFY RELATED REPAIR INFORMATION AVAILABILITY</b> <ul style="list-style-type: none"> <li>• Verify related Service Bulletins and/or on-line repair information availability.</li> <li>• Is any related Service Bulletins available?</li> </ul>	Yes	Perform repair or diagnosis according to the available Service Bulletins. <ul style="list-style-type: none"> <li>• If the vehicle is not repaired, go to the next step.</li> </ul>
		No	Go to the next step.
3	<b>INSPECT APP SENSOR CONNECTOR FOR POOR CONNECTION</b> <ul style="list-style-type: none"> <li>• Turn the ignition switch off.</li> <li>• Disconnect the APP sensor connector.</li> <li>• Inspect for poor connection (such as damaged/pulled-out pins, corrosion).</li> <li>• Are there any malfunction?</li> </ul>	Yes	Repair or replace suspected part, then go to Step 7.
		No	Go to the next step.
4	<b>INSPECT APP SENSOR NO.3 CIRCUIT FOR SHORT TO GROUND</b> <ul style="list-style-type: none"> <li>• Turn the ignition switch off.</li> <li>• Inspect for continuity between the following terminals:                             <ul style="list-style-type: none"> <li>○ APP sensor terminal F and body ground.</li> <li>○ APP sensor terminal D and body ground.</li> <li>○ APP sensor terminal G and body ground.</li> <li>○ APP sensor terminal C and body ground.</li> <li>○ APP sensor terminal B and body ground.</li> </ul> </li> <li>• Are there continuity?</li> </ul>	Yes	Repair or replace suspected part, then go to Step 7.
		No	Go to the next step.
5	<b>INSPECT APP SENSOR NO.3</b> <ul style="list-style-type: none"> <li>• Inspect APP sensor No.3.</li> </ul> (see <b><u>ACCELERATOR PEDAL</u></b> )	Yes	Replace the accelerator pedal, then go to Step 7. (see <b><u>ACCELERATOR PEDAL REMOVAL/INSTALLATION [MZI-3.5]</u></b> .)

## 2007 Mazda CX-9 Grand Touring

2007 ENGINE PERFORMANCE On-Board Diagnostic (MZI-3.5) - CX-9

	<p><b><u>POSITION (APP) SENSOR INSPECTION [MZI-3.5].</u></b></p> <ul style="list-style-type: none"> <li>• Is there any malfunction?</li> </ul>	No	Go to the next step.
6	<p><b>INSPECT PCM CONNECTOR FOR POOR CONNECTION</b></p> <ul style="list-style-type: none"> <li>• Turn the ignition switch off.</li> <li>• Disconnect the PCM connector.</li> <li>• Inspect for poor connection (such as damaged/pulled-out pins, corrosion).</li> <li>• Are there any malfunction?</li> </ul>	Yes	Repair or replace suspected part, then go to Step 7.
		No	Go to the next step.
7	<p><b>VERIFY TROUBLESHOOTING OF DTC P2132 HAS BEEN COMPLETED</b></p> <ul style="list-style-type: none"> <li>• Verify that all disconnected connectors reconnected.</li> <li>• Clear the DTC from the PCM memory using the M-MDS.</li> <li>• Start the engine.</li> <li>• Is the same DTC present?</li> </ul>	Yes	Replace the PCM, then go to the next step. (see <b><u>PCM REMOVAL/INSTALLATION [MZI-3.5].</u></b> )
		No	Go to the next step.
8	<p><b>VERIFY AFTER REPAIR PROCEDURE</b></p> <ul style="list-style-type: none"> <li>• Perform the "AFTER REPAIR PROCEDURE".</li> </ul> <p>(See <b><u>AFTER REPAIR PROCEDURE [MZI-3.5].</u></b>)</p> <ul style="list-style-type: none"> <li>• Are any DTC present?</li> </ul>	Yes	Go to the applicable DTC inspection. (See <b><u>DTC TABLE [MZI-3.5].</u></b> )
		No	DTC troubleshooting completed.

### DTC P2133 [MZI-3.5]

#### DTC P2133 (MZI-3.5) DETECTION CONDITION AND POSSIBLE CAUSES

<b>DTC P2133</b>	<b>APP sensor No.3 circuit high input</b>
<b>DETECTION CONDITION</b>	<ul style="list-style-type: none"> <li>• APP sensor No.3 is out of self-test range high.</li> </ul>
	<ul style="list-style-type: none"> <li>• Open circuit wiring harness between APP sensor terminal F and PCM terminal 1F</li> <li>• Open circuit wiring harness between APP sensor terminal D and PCM terminal 1'</li> <li>• Open circuit wiring harness between APP sensor terminal G and PCM terminal 1.</li> </ul>

## 2007 Mazda CX-9 Grand Touring

2007 ENGINE PERFORMANCE On-Board Diagnostic (MZI-3.5) - CX-9

### POSSIBLE CAUSE

- Open circuit wiring harness between APP sensor terminal C and PCM terminal 1Z
- Open circuit wiring harness between APP sensor terminal B and PCM terminal 1Z
- Short to power supply in wiring harness between APP sensor terminal F and PCM terminal 1BA
- Short to power supply in wiring harness between APP sensor terminal D and PCM terminal 1Y
- Short to power supply in wiring harness between APP sensor terminal G and PCM terminal 1AD
- Short to power supply in wiring harness between APP sensor terminal C and PCM terminal 1AH
- Short to power supply in wiring harness between APP sensor terminal B and PCM terminal 1AC
- Connector or terminal malfunction
- APP sensor malfunction

## 2007 Mazda CX-9 Grand Touring

2007 ENGINE PERFORMANCE On-Board Diagnostic (MZI-3.5) - CX-9

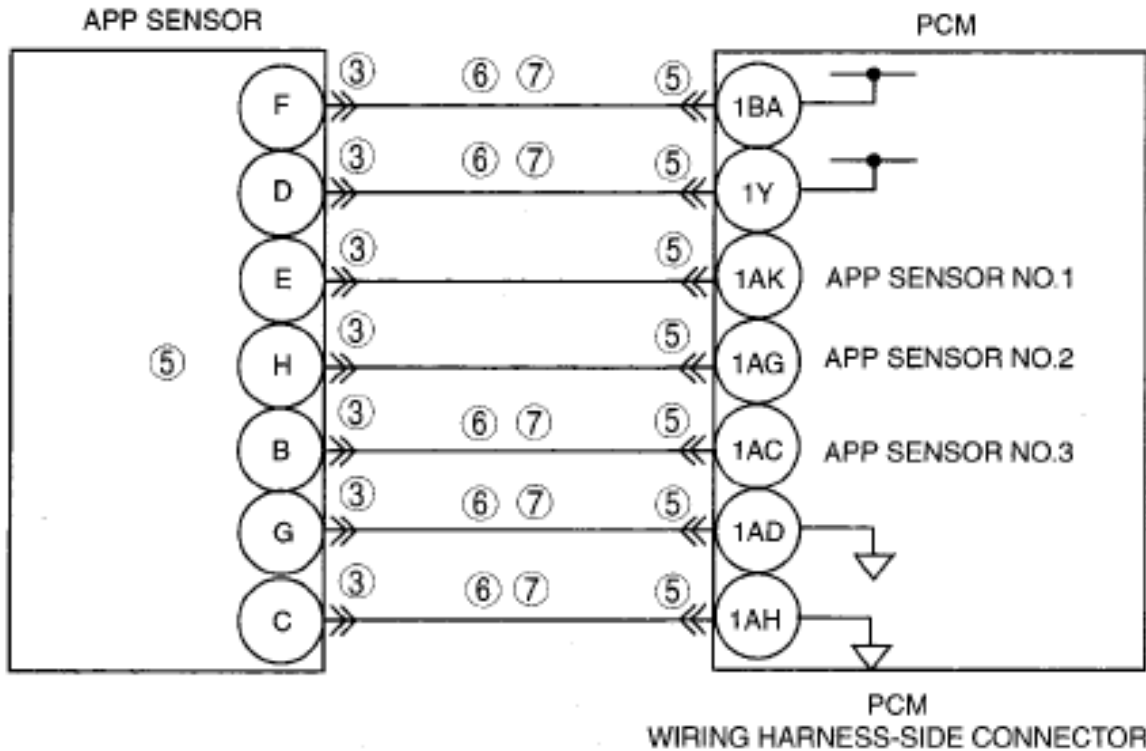

APP SENSOR  
WIRING HARNESS-SIDE CONNECTOR

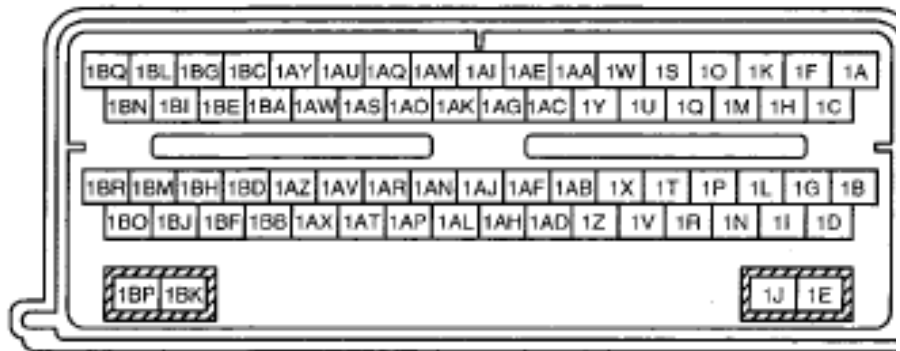
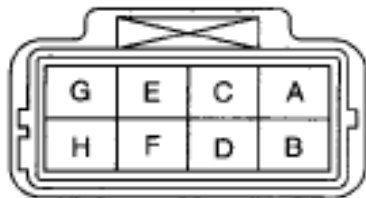

### DIAGNOSTIC PROCEDURE

#### DTC P2133 (MZI-3.5) DIAGNOSTIC PROCEDURE

STEP	INSPECTION		ACTION
1	<b>VERIFY FREEZE FRAME DATA HAS BEEN RECORDED</b>	Yes	Go to the next step.
		No	Record FREEZE FRAME DATA on the repair order, then go to the next step.
	<ul style="list-style-type: none"> <li>Has FREEZE FRAME DATA</li> </ul>		



## 2007 Mazda CX-9 Grand Touring

2007 ENGINE PERFORMANCE On-Board Diagnostic (MZI-3.5) - CX-9

	been recorded?		
2	<b>VERIFY RELATED REPAIR INFORMATION AVAILABILITY</b> <ul style="list-style-type: none"> <li>• Verify related Service Bulletins and/or on-line repair information availability.</li> <li>• Is any related Service Bulletins available?</li> </ul>	Yes	Perform repair or diagnosis according to the available Service Bulletins. <ul style="list-style-type: none"> <li>• If the vehicle is not repaired, go to the next step.</li> </ul>
		No	Go to the next step.
3	<b>INSPECT APP SENSOR CONNECTOR FOR POOR CONNECTION</b> <ul style="list-style-type: none"> <li>• Turn the ignition switch off.</li> <li>• Disconnect the APP sensor connector.</li> <li>• Inspect for poor connection (such as damaged/pulled-out pins, corrosion).</li> <li>• Are there any malfunction?</li> </ul>	Yes	Repair or replace suspected part, then go to Step 8.
		No	Go to the next step.
4	<b>INSPECT APP SENSOR NO.3</b> <ul style="list-style-type: none"> <li>• Inspect APP sensor No.3.</li> </ul> (see <b><u>ACCELERATOR PEDAL POSITION (APP) SENSOR INSPECTION [MZI-3.5].</u></b> )	Yes	Replace the accelerator pedal, then go to Step 8. (see <b><u>ACCELERATOR PEDAL REMOVAL/INSTALLATION [MZI-3.5]</u></b> .)
		No	Go to the next step.
5	<b>INSPECT PCM CONNECTOR FOR POOR CONNECTION</b> <ul style="list-style-type: none"> <li>• Turn the ignition switch off.</li> <li>• Disconnect the PCM connector.</li> <li>• Inspect for poor connection (such as damaged/pulled-out pins, corrosion).</li> <li>• Are there any malfunction?</li> </ul>	Yes	Repair or replace suspected part, then go to Step 8.
		No	Go to the next step.
6	<b>INSPECT APP SENSOR NO.3 CIRCUIT FOR OPEN CIRCUIT</b> <ul style="list-style-type: none"> <li>• Turn the ignition switch off.</li> <li>• Inspect for continuity between the following terminals (wiring</li> </ul>	Yes	Go to the next step.

## 2007 Mazda CX-9 Grand Touring

2007 ENGINE PERFORMANCE On-Board Diagnostic (MZI-3.5) - CX-9

	<p>harness-side).</p> <ul style="list-style-type: none"> <li>○ APP sensor terminal F and PCM terminal 1BA.</li> <li>○ APP sensor terminal D and PCM terminal 1Y.</li> <li>○ APP sensor terminal G and PCM terminal 1AD.</li> <li>○ APP sensor terminal C and PCM terminal 1AH.</li> <li>○ APP sensor terminal B and PCM terminal 1AC.</li> </ul> <ul style="list-style-type: none"> <li>● Are there continuity?</li> </ul>	No	Repair or replace suspected part, then go to Step 8.
7	<p><b>INSPECT APP SENSOR NO.3 SIGNAL CIRCUIT FOR SHORT TO POWER SUPPLY</b></p> <ul style="list-style-type: none"> <li>● Turn the ignition switch to the ON position (Engine off).</li> <li>● Measure the voltage between the following terminals (wiring harness-side). <ul style="list-style-type: none"> <li>○ APP sensor terminal F and body ground.</li> <li>○ APP sensor terminal D and body ground.</li> <li>○ APP sensor terminal G and body ground.</li> <li>○ APP sensor terminal C and body ground.</li> <li>○ APP sensor terminal B and body ground.</li> </ul> </li> <li>● Are there voltage <b>B+</b> ?</li> </ul>	Yes	Repair or replace suspected part, then go to Step 8.
		No	Go to the next step.
8	<p><b>VERIFY TROUBLESHOOTING OF DTC P2133 HAS BEEN COMPLETED</b></p> <ul style="list-style-type: none"> <li>● Verify that all disconnected connectors reconnected.</li> <li>● Clear the DTC from the PCM memory using the M-MDS.</li> <li>● Start the engine.</li> <li>● Is the same DTC present?</li> </ul>	Yes	Replace the PCM, then go to the next step. (see <b><u>PCM REMOVAL/INSTALLATION [MZI-3.5]</u></b> .)
		No	Go to the next step.

## 2007 Mazda CX-9 Grand Touring

2007 ENGINE PERFORMANCE On-Board Diagnostic (MZI-3.5) - CX-9

9	<b>VERIFY AFTER REPAIR PROCEDURE</b> <ul style="list-style-type: none"><li>• Perform the "AFTER REPAIR PROCEDURE".</li></ul> <p>(See <b><u>AFTER REPAIR PROCEDURE [MZI-3.5]</u></b>.)</p> <ul style="list-style-type: none"><li>• Are any DTC present?</li></ul>	Yes	Go to the applicable DTC inspection. (See <b><u>DTC TABLE [MZI-3.5]</u></b> .)
		No	DTC troubleshooting completed.

### DTC P2135 [MZI-3.5]

#### DTC P2135 (MZI-3.5) DETECTION CONDITION AND POSSIBLE CAUSES

<b>DTC P2135</b>	<b>TP sensor No.1/No.2 voltage correlation</b>
<b>DETECTION CONDITION</b>	<ul style="list-style-type: none"><li>• The PCM flagged a concern indicating that TP sensor No.1 and TP sensor No.2 disagree by more than a calibrated limit.</li></ul>
<b>POSSIBLE CAUSE</b>	<ul style="list-style-type: none"><li>• Short to power supply between TP sensor No.1 terminal F and PCM terminal 2Z</li><li>• Short to power supply between TP sensor No.2 terminal C and PCM terminal 2AI</li><li>• TP sensor circuits are shorted each other</li><li>• TP sensor malfunction</li></ul>

# 2007 Mazda CX-9 Grand Touring

2007 ENGINE PERFORMANCE On-Board Diagnostic (MZI-3.5) - CX-9

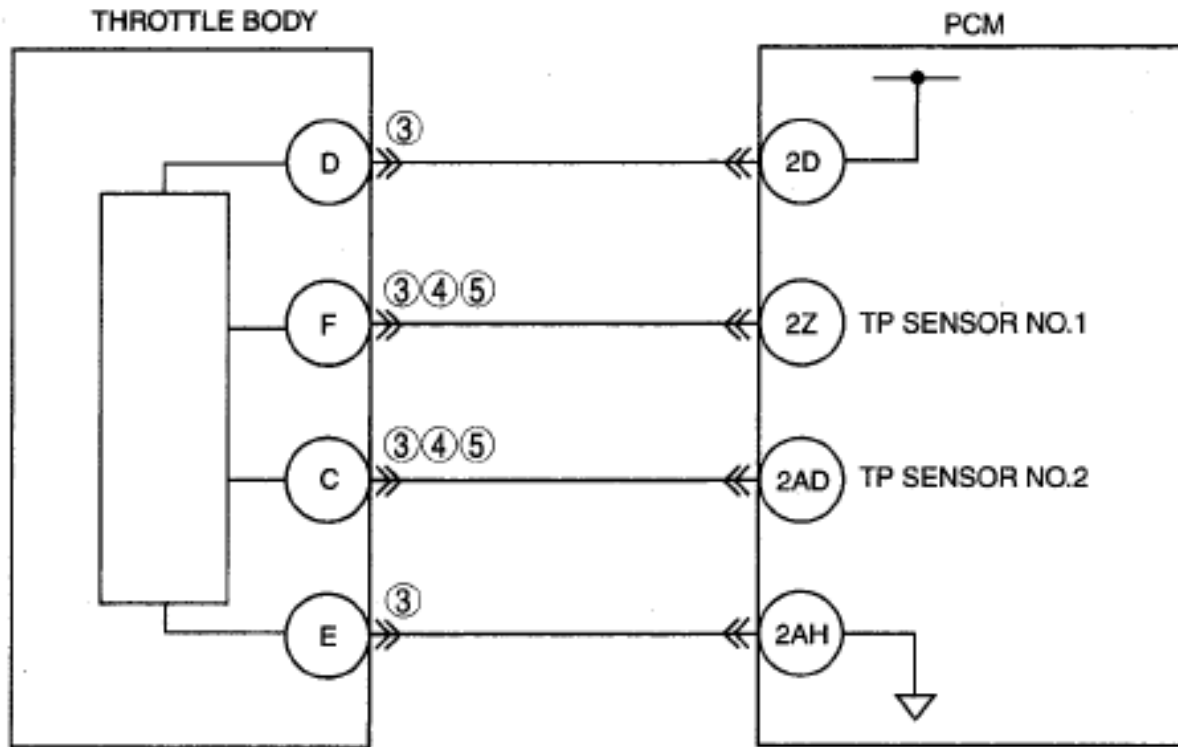

**THROTTLE BODY WIRING HARNESS-SIDE CONNECTOR**

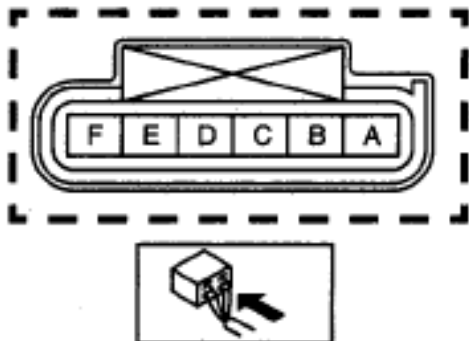

**PCM WIRING HARNESS-SIDE CONNECTOR**

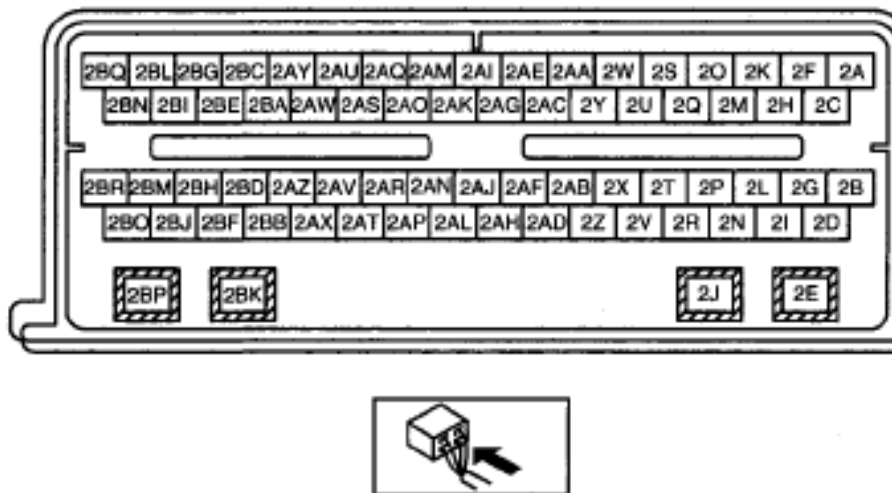

## DIAGNOSTIC PROCEDURE

### DTC P2135 (MZI-3.5) DIAGNOSTIC PROCEDURE

STEP	INSPECTION	ACTION

## 2007 Mazda CX-9 Grand Touring

2007 ENGINE PERFORMANCE On-Board Diagnostic (MZI-3.5) - CX-9

1	<b>VERIFY FREEZE FRAME DATA HAS BEEN RECORDED</b> <ul style="list-style-type: none"> <li>• Has FREEZE FRAME DATA been recorded?</li> </ul>	Yes	Go to the next step.
		No	Record the FREEZE FRAME DATA on the repair order, then go to the next step.
2	<b>VERIFY RELATED REPAIR INFORMATION AVAILABILITY</b> <ul style="list-style-type: none"> <li>• Verify related Service Bulletins and/or on-line repair information availability.</li> <li>• Is any related Service Bulletins available?</li> </ul>	Yes	Perform repair or diagnosis according to the available Service Bulletins. <ul style="list-style-type: none"> <li>• If the vehicle is not repaired, go to the next step.</li> </ul>
		No	Go to the next step.
3	<b>INSPECT TP SENSOR RESISTANCE</b> <ul style="list-style-type: none"> <li>• Turn the ignition switch off.</li> <li>• Disconnect the throttle body connector.</li> <li>• Measure the resistance between the following terminals (throttle body component side).               <ul style="list-style-type: none"> <li>○ Throttle body terminal F and D: 700-1,800 ohms</li> <li>○ Throttle body terminal F and E: 1,300-2,800 ohms</li> <li>○ Throttle body terminal C and D: 1,000-2,400 ohms</li> <li>○ Throttle body terminal C and E: 500-1,500 ohms</li> <li>○ Throttle body terminal D and E: 700-2,100 ohms</li> </ul> </li> <li>• Are all the resistances within specifications?</li> </ul>	Yes	Go to the next step.
		No	Replace the throttle body, then go to Step 6. (see <b><u>INTAKE-AIR SYSTEM REMOVAL/INSTALLATION [MZI-3.5]</u></b> .)
4	<b>INSPECT TP SENSOR SIGNAL CIRCUIT FOR SHORT TO POWER SUPPLY</b> <ul style="list-style-type: none"> <li>• Turn the ignition switch to the ON position (Engine off).</li> <li>• Measure the voltage between the following circuits:               <ul style="list-style-type: none"> <li>○ Throttle body terminal F (wiring harness-side) and</li> </ul> </li> </ul>	Yes	Repair or replace suspected part, then go to Step 6.

## 2007 Mazda CX-9 Grand Touring

2007 ENGINE PERFORMANCE On-Board Diagnostic (MZI-3.5) - CX-9

	<p>body ground.</p> <ul style="list-style-type: none"> <li>○ Throttle body terminal C (wiring harness-side) and body ground.</li> </ul> <ul style="list-style-type: none"> <li>● Are there voltage <b>B+</b> ?</li> </ul>	No	Go to the next step.
5	<p><b>INSPECT TP SENSOR SIGNAL CIRCUITS FOR SHORT EACH OTHER</b></p> <ul style="list-style-type: none"> <li>● Turn the ignition switch off.</li> <li>● Disconnect the throttle body and PCM connector.</li> <li>● Measure resistance between throttle body terminal F and C.</li> <li>● Is the resistance <b>more than 10 kilohms</b> ?</li> </ul>	Yes	Go to the next step.
		No	Repair or replace suspected part, then go to the next step.
6	<p><b>VERIFY TROUBLESHOOTING OF DTC P2135 HAS BEEN COMPLETED</b></p> <ul style="list-style-type: none"> <li>● Verify that all disconnected connectors reconnected.</li> <li>● Clear the DTC from the PCM memory using the M-MDS.</li> <li>● Start the engine.</li> <li>● Is the same DTC present?</li> </ul>	Yes	Replace the PCM, then go to the next step. (see <b>PCM REMOVAL/INSTALLATION [MZI-3.5]</b> .)
		No	Go to the next step.
7	<p><b>VERIFY AFTER REPAIR PROCEDURE</b></p> <ul style="list-style-type: none"> <li>● Perform the "AFTER REPAIR PROCEDURE".</li> </ul> <p>(See <b>AFTER REPAIR PROCEDURE [MZI-3.5]</b>.)</p> <ul style="list-style-type: none"> <li>● Are any DTCs present?</li> </ul>	Yes	Go to the applicable DTC inspection. (See <b>DTC TABLE [MZI-3.5]</b> .)
		No	DTC troubleshooting completed.

### DTC P2195, P2197 [MZI-3.5]

#### DTC P2195, P2197 (MZI-3.5) DETECTION CONDITION AND POSSIBLE CAUSES

<b>DTC P2195</b>	<b>P2195: Front HO2S (RH) signal stuck lean</b>
<b>DTC P2197</b>	<b>P2197: Front HO2S (LH) signal stuck lean</b>
<b>DETECTION</b>	<ul style="list-style-type: none"> <li>● A HO2S indicating lean at the end of a test is trying to correct for an over-</li> </ul>

## 2007 Mazda CX-9 Grand Touring

2007 ENGINE PERFORMANCE On-Board Diagnostic (MZI-3.5) - CX-9

<b>CONDITION</b>	rich condition. The test fails when the fuel control system no longer detects switching for a calibrated amount of time.
<b>POSSIBLE CAUSE</b>	<ul style="list-style-type: none"> <li>• Front HO2S malfunction</li> <li>• Fuel injector malfunction</li> <li>• Insufficient fuel line pressure</li> <li>• Leakage exhaust gas</li> <li>• Air suction at intake-air system malfunction</li> <li>• Leakage fuel</li> <li>• MAF sensor malfunction</li> <li>• ECT sensor malfunction</li> <li>• PCM malfunction</li> </ul>

### DIAGNOSTIC PROCEDURE

#### DTC P2195, P2197 (MZI-3.5) DIAGNOSTIC PROCEDURE

STEP	INSPECTION		ACTION
1	<b>VERIFY FREEZE FRAME DATA HAS BEEN RECORDED</b> <ul style="list-style-type: none"> <li>• Has FREEZE FRAME DATA been recorded?</li> </ul>	Yes	Go to the next step.
		No	Record FREEZE FRAME DATA on the repair order, then go to the next step.
2	<b>VERIFY RELATED REPAIR INFORMATION AVAILABILITY</b> <ul style="list-style-type: none"> <li>• Is any related Service Bulletins available?</li> </ul>	Yes	Perform repair or diagnosis according to the available Service Bulletins. <ul style="list-style-type: none"> <li>• If the vehicle is not repaired, go to the next step.</li> </ul>
		No	Perform the PCM reprogramming procedure. (see <b>PCM CONFIGURATION [MZI-3.5]</b> .) Then go to the next step.
3	<b>VERIFY RELATED PENDING CODE OR STORED DTCs</b> <ul style="list-style-type: none"> <li>• Turn the ignition switch off then to the ON position (Engine off).</li> <li>• Verify the related PENDING CODE or stored DTCs using the M-MDS.</li> </ul>	Yes	Go to the appropriate DTC troubleshooting. (See <b>DTC TABLE [MZI-3.5]</b> .)
		No	Go to the next step.
4	<b>IDENTIFY TRIGGER DTC FOR FREEZE FRAME DATA</b> <ul style="list-style-type: none"> <li>• Is DTC P2195 or P2197 on the</li> </ul>	Yes	Go to the next step.
		No	Go to the troubleshooting for the DTC on the "FREEZE FRAME DATA". (See <b>DTC TABLE [MZI-3.5]</b> .)

## 2007 Mazda CX-9 Grand Touring

2007 ENGINE PERFORMANCE On-Board Diagnostic (MZI-3.5) - CX-9

FREEZE FRAME DATA?			
5	<b>VERIFY CURRENT INPUT SIGNAL STATUS</b> <ul style="list-style-type: none"> <li>• Connect the M-MDS to the DLC-2.</li> <li>• Verify the following PIDs.</li> <li>• (see <b><u>PCM INSPECTION [MZI-3.5]</u></b> .)                             <ul style="list-style-type: none"> <li>○ APP1</li> <li>○ APP2</li> <li>○ APP3</li> <li>○ ECT</li> <li>○ MAF</li> <li>○ TP_REL</li> <li>○ VSS</li> </ul> </li> <li>• Are the PIDs normal?</li> </ul>	Yes	Go to the next step.
		No	Inspect the malfunctioning part according to the inspection results. Then go to Step 13.
6	<b>VERIFY CURRENT INPUT SIGNAL STATUS UNDER FREEZE FRAME DATA CONDITION</b> <ul style="list-style-type: none"> <li>• Connect the M-MDS to the DLC-2.</li> <li>• Verify the following PIDs under the FREEZE FRAME DATA condition.</li> <li>• (see <b><u>PCM INSPECTION [MZI-3.5]</u></b> .)                             <ul style="list-style-type: none"> <li>○ APP1</li> <li>○ APP2</li> <li>○ APP3</li> <li>○ ECT</li> <li>○ MAF</li> <li>○ TP_REL</li> </ul> </li> <li>• Are the PIDs normal?</li> </ul>	Yes	Go to the next step.
		No	Inspect the malfunctioning part according to the inspection results. Then go to Step 13.
7	<b>INSPECT INTAKE AIR SYSTEM FOR EXCESSIVE AIR SUCTION</b> <ul style="list-style-type: none"> <li>• Visually inspect for looseness, cracks or damage to the hoses in</li> </ul>	Yes	Repair or replace the malfunctioning part, then go to Step 13.



## 2007 Mazda CX-9 Grand Touring

2007 ENGINE PERFORMANCE On-Board Diagnostic (MZI-3.5) - CX-9

	<p>the intake-air system.</p> <ul style="list-style-type: none"> <li>• Is there any malfunction?</li> </ul>	No	Go to the next step.
8	<p><b>VERIFY CURRENT INPUT SIGNAL STATUS OF MAF SENSOR</b></p> <ul style="list-style-type: none"> <li>• Connect the M-MDS to the DLC-2.</li> <li>• Start the engine.</li> <li>• Access the MAF PID.</li> <li>• Verify that the MAF PID changes quickly according to the engine speed.</li> <li>• Is the PID normal?</li> </ul>	Yes	Go to the next step.
		No	Replace the MAF/IAT sensor, then go to Step 13.
9	<p><b>INSPECT FRONT HO2S</b></p> <ul style="list-style-type: none"> <li>• Inspect the front HO2S (RH) (with DTC P2195) or the front HO2S (LH) (with DTC P2197).</li> </ul> <p>(see <b><u>FRONT HEATED OXYGEN SENSOR (HO2S) INSPECTION [MZI-3.5].</u></b>)</p> <ul style="list-style-type: none"> <li>• Is there any malfunction?</li> </ul>	Yes	Inspect the related wiring harnesses. If there is no malfunction, replace the HO2S. Then go to Step 13.
		No	Go to the next step.
10	<p><b>INSPECT FUEL INJECTOR</b></p> <ul style="list-style-type: none"> <li>• Inspect the fuel injector for the right bank (with DTC P2195) or the left bank (with DTC P2197).</li> </ul> <p>(see <b><u>FUEL INJECTOR INSPECTION [MZI-3.5].</u></b>)</p> <ul style="list-style-type: none"> <li>• Is there any malfunction?</li> </ul>	Yes	Replace the suspected fuel injector, then go to Step 13. (see <b><u>FUEL INJECTOR REMOVAL/INSTALLATION [MZI-3.5].</u></b> )
		No	Go to the next step.
11	<p><b>INSPECT FUEL LINE PRESSURE</b></p> <ul style="list-style-type: none"> <li>• Perform the "FUEL LINE PRESSURE INSPECTION".</li> </ul> <p>(see <b><u>FUEL LINE PRESSURE INSPECTION [MZI-3.5].</u></b>)</p> <ul style="list-style-type: none"> <li>• Is there any malfunction?</li> </ul>	Yes	Go to the next step.
		No	Go to Step 13.
12	<p><b>INSPECT FUEL SYSTEM FOR FUEL LEAKAGE</b></p>	Yes	Repair or replace the malfunctioning part, then go to the next step.

## 2007 Mazda CX-9 Grand Touring

2007 ENGINE PERFORMANCE On-Board Diagnostic (MZI-3.5) - CX-9

	<ul style="list-style-type: none"> <li>• Visually inspect for fuel leakage in the fuel system.</li> <li>• Is there fuel leakage?</li> </ul>	No	Replace the fuel pump unit, then go to the next step. (see <b><u>FUEL PUMP UNIT REMOVAL/INSTALLATION [MZI-3.5]</u></b> .)
13	<p><b>VERIFY TROUBLESHOOTING OF DTC P2195, P2197 HAS BEEN COMPLETED</b></p> <ul style="list-style-type: none"> <li>• Verify that all disconnected connectors are reconnected.</li> <li>• Turn the ignition switch to the ON position (Engine off).</li> <li>• Clear the DTC from the PCM memory using the M-MDS.</li> <li>• Perform no load racing at the engine speed of 2,500-3,500 rpm for 60s or more, then idle the engine for 60s or more.</li> <li>• Perform the KOEO and KOER self-test.</li> <li>• Retrieve DTCs using the M-MDS.</li> <li>• Is the PENDING CODE for this DTC present?</li> </ul>	Yes	Replace the PCM, then go to the next step. (see <b><u>PCM REMOVAL/INSTALLATION [MZI-3.5]</u></b> .)
		No	Go to the next step.
14	<p><b>VERIFY AFTER REPAIR PROCEDURE</b></p> <ul style="list-style-type: none"> <li>• Perform "AFTER REPAIR PROCEDURE".</li> </ul> <p>(See <b><u>AFTER REPAIR PROCEDURE [MZI-3.5]</u></b>.)</p> <ul style="list-style-type: none"> <li>• Are any DTC present?</li> </ul>	Yes	Go to the applicable DTC inspection. (See <b><u>DTC TABLE [MZI-3.5]</u></b> .)
		No	Troubleshooting completed.

### DTC P2196, P2198 [MZI-3.5]

#### DTC P2196, P2198 (MZI-3.5) DETECTION CONDITION AND POSSIBLE CAUSES

<b>DTC P2196</b>	<b>P2196: Front HO2S (RH) signal stuck rich</b>
<b>DTC P2198</b>	<b>P2198: Front HO2S (LH) signal stuck rich</b>
<b>DETECTION CONDITION</b>	<ul style="list-style-type: none"> <li>• A HO2S indicating rich at the end of a test is trying to correct for an over-rich condition. The test fails when the fuel control system no longer detects switching for a calibrated amount of time</li> </ul>

## 2007 Mazda CX-9 Grand Touring

2007 ENGINE PERFORMANCE On-Board Diagnostic (MZI-3.5) - CX-9

<b>POSSIBLE CAUSE</b>	<ul style="list-style-type: none"> <li>• Front HO2S malfunction</li> <li>• Fuel injector malfunction</li> <li>• Insufficient fuel line pressure</li> <li>• Leakage exhaust gas</li> <li>• Air suction at intake-air system malfunction</li> <li>• Leakage fuel</li> <li>• MAF sensor malfunction</li> <li>• ECT sensor malfunction</li> <li>• PCM malfunction</li> </ul>
-----------------------	--

### DIAGNOSTIC PROCEDURE

#### DTC P2196, P2198 (MZI-3.5) DIAGNOSTIC PROCEDURE

STEP	INSPECTION	ACTION	
1	<b>VERIFY FREEZE FRAME DATA HAS BEEN RECORDED</b> <ul style="list-style-type: none"> <li>• Has FREEZE FRAME DATA been recorded?</li> </ul>	Yes	Go to the next step.
		No	Record FREEZE FRAME DATA on the repair order, then go to the next step.
2	<b>VERIFY RELATED REPAIR INFORMATION AVAILABILITY</b> <ul style="list-style-type: none"> <li>• Verify related Service Bulletins and/or online repair information availability.</li> <li>• Is any related Service Bulletins available?</li> </ul>	Yes	Perform repair or diagnosis according to the available Service Bulletins. <ul style="list-style-type: none"> <li>• If the vehicle is not repaired, go to the next step.</li> </ul>
		No	Perform the PCM reprogramming procedure. Then go to the next step.
3	<b>VERIFY RELATED PENDING CODE OR STORED DTCs</b> <ul style="list-style-type: none"> <li>• Turn the ignition switch off then to the ON position (Engine off).</li> <li>• Verify the related PENDING CODE or stored DTCs using the M-MDS.</li> </ul>	Yes	Go to the appropriate DTC troubleshooting. (See <b>DTC TABLE [MZI-3.5]</b> .)
		No	Go to the next step.
4	<b>IDENTIFY TRIGGER DTC FOR FREEZE FRAME DATA</b> <ul style="list-style-type: none"> <li>• Is DTC P2196 or P2198 on the FREEZE FRAME DATA?</li> </ul>	Yes	Go to the next step.
		No	Go to the troubleshooting for the DTC on the "FREEZE FRAME DATA" . (See <b>DTC TABLE [MZI-3.5]</b> .)
5	<b>VERIFY CURRENT INPUT SIGNAL STATUS</b>	Yes	Go to the next step.

## 2007 Mazda CX-9 Grand Touring

2007 ENGINE PERFORMANCE On-Board Diagnostic (MZI-3.5) - CX-9

	<ul style="list-style-type: none"> <li>• Connect the M-MDS to the DLC-2.</li> <li>• Verify the following PIDs.</li> </ul> <p>(see <b><u>PCM INSPECTION [MZI-3.5]</u></b> .)</p> <ul style="list-style-type: none"> <li>○ APP1</li> <li>○ APP2</li> <li>○ APP3</li> <li>○ ECT</li> <li>○ MAF</li> <li>○ TP_REL</li> <li>○ VSS</li> </ul> <ul style="list-style-type: none"> <li>• Are the PIDs normal?</li> </ul>	No	Inspect the malfunctioning part according to the inspection results. Then go to Step 11.
6	<p><b>VERIFY CURRENT INPUT SIGNAL STATUS UNDER FREEZE FRAME DATA CONDITION</b></p> <ul style="list-style-type: none"> <li>• Connect the M-MDS to the DLC-2.</li> <li>• Verify the following PIDs under the FREEZE FRAME DATA condition.</li> </ul> <p>(see <b><u>PCM INSPECTION [MZI-3.5]</u></b> .)</p> <ul style="list-style-type: none"> <li>○ APP1</li> <li>○ APP2</li> <li>○ APP3</li> <li>○ ECT</li> <li>○ MAF</li> <li>○ TP_REL</li> <li>○ VSS</li> </ul> <ul style="list-style-type: none"> <li>• Are the PIDs normal?</li> </ul>	Yes	Go to the next step.
		No	Inspect the malfunctioning part according to the inspection results. Then go to Step 11.
7	<p><b>VERIFY CURRENT INPUT SIGNAL STATUS OF MAF SENSOR</b></p> <ul style="list-style-type: none"> <li>• Connect the M-MDS to the DLC-2.</li> <li>• Start the engine.</li> </ul>	Yes	Go to the next step.
		No	Replace the MAF/IAT sensor, then go to Step 11.

## 2007 Mazda CX-9 Grand Touring

2007 ENGINE PERFORMANCE On-Board Diagnostic (MZI-3.5) - CX-9

	<ul style="list-style-type: none"> <li>• Access the MAF PID.</li> <li>• Verify that the MAF PID changes quickly according to engine speed.</li> <li>• Is the PID normal?</li> </ul>		
8	<p><b>INSPECT FRONT HO2S</b></p> <ul style="list-style-type: none"> <li>• Inspect the front HO2S (RH) (with DTC P2195) or the front HO2S (LH) (with DTC P2197).</li> </ul> <p>(see <b><u>FRONT HEATED OXYGEN SENSOR (HO2S) INSPECTION [MZI-3.5]</u></b>.)</p> <ul style="list-style-type: none"> <li>• Is there any malfunction?</li> </ul>	Yes	Inspect the related wiring harnesses If there is no malfunction Replace the HO2S, then go to Step 11.
		No	Go to the next step.
9	<p><b>INSPECT FUEL INJECTOR</b></p> <ul style="list-style-type: none"> <li>• Inspect the fuel injector for the right bank (with DTC P2196) or the left bank (with DTC P2198).</li> </ul> <p>(see <b><u>FUEL INJECTOR INSPECTION [MZI-3.5]</u></b>.)</p> <ul style="list-style-type: none"> <li>• Is there any malfunction?</li> </ul>	Yes	Replace the suspected fuel injector, then go to Step 11. (see <b><u>FUEL INJECTOR REMOVAL/INSTALLATION [MZI-3.5]</u></b> .)
		No	Go to the next step.
10	<p><b>INSPECT FUEL LINE PRESSURE</b></p> <ul style="list-style-type: none"> <li>• Perform the "FUEL LINE PRESSURE INSPECTION".</li> </ul> <p>(see <b><u>FUEL LINE PRESSURE INSPECTION [MZI-3.5]</u></b>.)</p> <ul style="list-style-type: none"> <li>• Is there any malfunction?</li> </ul>	Yes	Replace the malfunctioning part. Go to the next step.
		No	Go to the next step.
11	<p><b>VERIFY TROUBLESHOOTING OF DTC P2196, P2198 HAS BEEN COMPLETED</b></p> <ul style="list-style-type: none"> <li>• Verify that all disconnected connectors are reconnected.</li> <li>• Turn the ignition switch to the ON position (Engine off).</li> <li>• Clear the DTC from the PCM memory using the M-MDS.</li> </ul>	Yes	Replace the PCM, then go to the next step. (see <b><u>PCM REMOVAL/INSTALLATION [MZI-3.5]</u></b> .)

## 2007 Mazda CX-9 Grand Touring

2007 ENGINE PERFORMANCE On-Board Diagnostic (MZI-3.5) - CX-9

	<ul style="list-style-type: none"> <li>Perform no load racing at the engine speed of 2,500-3,500 rpm for 60s or more, then idle the engine for 60s or more.</li> <li>Perform KOEO and KOER self-test.</li> <li>Retrieve DTCs using the M-MDS.</li> <li>Is the PENDING CODE for this DTC present?</li> </ul>	No	Go to the next step.
12	<p><b>VERIFY AFTER REPAIR PROCEDURE</b></p> <ul style="list-style-type: none"> <li>Perform "AFTER REPAIR PROCEDURE".</li> </ul> <p>(See <b><u>AFTER REPAIR PROCEDURE [MZI-3.5].</u></b>)</p> <ul style="list-style-type: none"> <li>Are any DTC present?</li> </ul>	Yes	Go to the applicable DTC inspection. (See <b><u>DTC TABLE [MZI-3.5].</u></b> )
		No	Troubleshooting completed.

### DTC P2270, P2272 [MZI-3.5]

#### DTC P2270, P2272 (MZI-3.5) DETECTION CONDITION AND POSSIBLE CAUSES

<b>DTC P2270</b>	<b>P2270: Rear HO2S (RH) signal stuck lean</b>
<b>DTC P2272</b>	<b>P2272: Rear HO2S (LH) signal stuck lean</b>
<b>DETECTION CONDITION</b>	<ul style="list-style-type: none"> <li>The downstream HO2S is forced rich and monitored by the PCM. The test fails if the PCM does not detect the output of the HO2S in a calibrated amount of time</li> </ul>
<b>POSSIBLE CAUSE</b>	<ul style="list-style-type: none"> <li>Rear HO2S malfunction</li> <li>Leakage exhaust gas</li> </ul>

#### DIAGNOSTIC PROCEDURE

#### DTC P2270, P2272 (MZI-3.5) DIAGNOSTIC PROCEDURE

STEP	INSPECTION		ACTION
1	<p><b>VERIFY FREEZE FRAME DATA HAS BEEN RECORDED</b></p> <ul style="list-style-type: none"> <li>Has FREEZE FRAME DATA been recorded?</li> </ul>	Yes	Go to the next step.
		No	Record FREEZE FRAME DATA on the repair order, then go to the next step.
2	<b>VERIFY RELATED REPAIR INFORMATION AVAILABILITY</b>	Yes	Perform repair or diagnosis according to the available Service Bulletins.

## 2007 Mazda CX-9 Grand Touring

2007 ENGINE PERFORMANCE On-Board Diagnostic (MZI-3.5) - CX-9

	<ul style="list-style-type: none"> <li>• Verify related Service Bulletins and/or on-line repair information availability.</li> <li>• Is any related Service Bulletins available?</li> </ul>		<ul style="list-style-type: none"> <li>• If the vehicle is not repaired, go to the next step.</li> </ul>
		No	Perform the PCM reprogramming procedure. (see <b><u>PCM CONFIGURATION [MZI-3.5]</u></b> .) Then go to the next step.
3	<b>VERIFY RELATED PENDING CODE OR STORED DTCs</b> <ul style="list-style-type: none"> <li>• Turn the ignition switch off then to the ON position (Engine off).</li> <li>• Verify the related PENDING CODE or stored DTCs using the M-MDS.</li> </ul>	Yes	Go to the appropriate DTC troubleshooting. (See <b><u>DTC TABLE [MZI-3.5]</u></b> .)
		No	Go to the next step.
4	<b>IDENTIFY TRIGGER DTC FOR FREEZE FRAME DATA</b> <ul style="list-style-type: none"> <li>• Is DTC P2270 or P2272 on the FREEZE FRAME DATA?</li> </ul>	Yes	Go to the next step.
		No	Go to the troubleshooting for the DTC on the "FREEZE FRAME DATA". (See <b><u>DTC TABLE [MZI-3.5]</u></b> .)
5	<b>INSPECT FOR EXHAUST GAS LEAKAGE</b> Visually inspect for exhaust gas leakage between the TWC and the rear HO2S. <ul style="list-style-type: none"> <li>• Is there any malfunction?</li> </ul>	Yes	Repair or replace the malfunctioning parts. Then go to the next step.
		No	Go to the next step.
6	<b>INSPECT REAR HO2S</b> <ul style="list-style-type: none"> <li>• For DTC P02270 Inspect the rear HO2S(RH)</li> <li>• For DTC P02272 Inspect the rear HO2S(LH)</li> </ul> (see <b><u>REAR HEATED OXYGEN SENSOR (HO2S) INSPECTION [MZI-3.5]</u></b> .) <ul style="list-style-type: none"> <li>• Is there any malfunction?</li> </ul>	Yes	Repair or replace the malfunctioning parts. Then go to the next step.
		No	Go to the next step.
7	<b>VERIFY TROUBLESHOOTING OF DTC P2270, P2272 HAS BEEN COMPLETED</b> <ul style="list-style-type: none"> <li>• Verify that all disconnected connectors are reconnected.</li> <li>• Turn the ignition switch to the ON</li> </ul>	Yes	Replace the PCM, then go to the next step. (see <b><u>PCM REMOVAL/INSTALLATION [MZI-3.5]</u></b> .)

## 2007 Mazda CX-9 Grand Touring

2007 ENGINE PERFORMANCE On-Board Diagnostic (MZI-3.5) - CX-9

	<p>position (Engine off).</p> <ul style="list-style-type: none"> <li>• Clear the DTC from the PCM memory using the M-MDS.</li> <li>• Perform no load racing at the engine speed of 2,500-3,500 rpm for 60s or more, then idle the engine for 60s or more.</li> <li>• Perform the KOEO and KOER self-test.</li> <li>• Retrieve DTCs using the M-MDS.</li> <li>• Is the PENDING CODE for this DTC present?</li> </ul>	No	Go to the next step.
8	<p><b>VERIFY AFTER REPAIR PROCEDURE</b></p> <ul style="list-style-type: none"> <li>• Perform "AFTER REPAIR PROCEDURE".</li> </ul> <p>(See <b><u>AFTER REPAIR PROCEDURE [MZI-3.5].</u></b>)</p> <ul style="list-style-type: none"> <li>• Are any DTC present?</li> </ul>	Yes	Go to the applicable DTC inspection. (See <b><u>DTC TABLE [MZI-3.5].</u></b> )
		No	Troubleshooting completed.

### DTC P2271, P2273 [MZI-3.5]

#### DTC P2271, P2273 (MZI-3.5) DETECTION CONDITION AND POSSIBLE CAUSES

<b>DTC P2271</b>	<b>P2271: Rear HO2S (RH) signal stuck rich</b>
<b>DTC P2273</b>	<b>P2273: Rear HO2S (LH) signal stuck rich</b>
<b>DETECTION CONDITION</b>	<ul style="list-style-type: none"> <li>• The downstream HO2S is forced rich and monitored by the PCM. The test fails if the PCM does not detect the output of the HO2S in a calibrated amount of time.</li> </ul>
<b>POSSIBLE CAUSE</b>	<ul style="list-style-type: none"> <li>• Rear HO2S malfunction</li> </ul>

#### DIAGNOSTIC PROCEDURE

#### DTC P2271, P2273 (MZI-3.5) DIAGNOSTIC PROCEDURE

STEP	INSPECTION		ACTION
1	<p><b>VERIFY FREEZE FRAME DATA HAS BEEN RECORDED</b></p> <ul style="list-style-type: none"> <li>• Has FREEZE FRAME DATA been recorded?</li> </ul>	Yes	Go to the next step.
		No	Record FREEZE FRAME DATA on the repair order, then go to the next step.
2	<b>VERIFY RELATED REPAIR</b>	Yes	Perform repair or diagnosis according to



## 2007 Mazda CX-9 Grand Touring

2007 ENGINE PERFORMANCE On-Board Diagnostic (MZI-3.5) - CX-9

	<p><b>INFORMATION AVAILABILITY</b></p> <ul style="list-style-type: none"> <li>• Verify related Service Bulletins and/or on-line repair information availability.</li> <li>• Is any related Service Bulletins available?</li> </ul>		<p>the available Service Bulletins.</p> <ul style="list-style-type: none"> <li>• If the vehicle is not repaired, go to the next step.</li> </ul>
		No	<p>Perform the PCM reprogramming procedure. (see <b>PCM CONFIGURATION [MZI-3.5]</b> .) Then go to the next step.</p>
3	<p><b>VERIFY RELATED PENDING CODE OR STORED DTCs</b></p> <ul style="list-style-type: none"> <li>• Turn the ignition switch off then to the ON position (Engine off).</li> <li>• Verify the related PENDING CODE or stored DTCs using the M-MDS.</li> </ul>	Yes	<p>Go to the appropriate DTC troubleshooting. (See <b>DTC TABLE [MZI-3.5]</b>.)</p>
		No	<p>Go to the next step.</p>
4	<p><b>IDENTIFY TRIGGER DTC FOR FREEZE FRAME DATA</b></p> <ul style="list-style-type: none"> <li>• Is DTC P2271 or P2273 on FREEZE FRAME DATA?</li> </ul>	Yes	<p>Go to the next step.</p>
		No	<p>Go to the troubleshooting for the DTC on the "FREEZE FRAME DATA". (See <b>DTC TABLE [MZI-3.5]</b>.)</p>
5	<p><b>INSPECT REAR HO2S</b></p> <ul style="list-style-type: none"> <li>• For DTC P2271 Inspect the rear HO2S(RH)</li> <li>• For DTC P2273 Inspect the rear HO2S(LH)</li> </ul> <p>(see <b>REAR HEATED OXYGEN SENSOR (HO2S) INSPECTION [MZI-3.5]</b> .)</p> <ul style="list-style-type: none"> <li>• Is there any malfunction?</li> </ul>	Yes	<p>Inspect the related wiring harnesses. If there is no malfunction, replace the HO2S. (see <b>REAR HEATED OXYGEN SENSOR (HO2S) REMOVAL/INSTALLATION [MZI-3.5]</b> .)</p>
		No	<p>Go to the next step.</p>
6	<p><b>VERIFY TROUBLESHOOTING OF DTC P2271, P2273 HAS BEEN COMPLETED</b></p> <ul style="list-style-type: none"> <li>• Verify that all disconnected connectors are reconnected.</li> <li>• Turn the ignition switch to the ON position (Engine off).</li> <li>• Clear the DTC from the PCM memory using the M-MDS.</li> <li>• Perform no load racing at the</li> </ul>	Yes	<p>Replace the PCM, then go to the next step. (see <b>PCM REMOVAL/INSTALLATION [MZI-3.5]</b> .)</p>

## 2007 Mazda CX-9 Grand Touring

2007 ENGINE PERFORMANCE On-Board Diagnostic (MZI-3.5) - CX-9

	<p>engine speed of 2,500-3,500 rpm for 60s or more, then idle the engine for 60s or more.</p> <ul style="list-style-type: none"> <li>• Perform the KOEO and KOER self-test.</li> <li>• Retrieve DTCs using the M-MDS.</li> <li>• Is the PENDING CODE for this DTC present?</li> </ul>	No	Go to the next step.
7	<p><b>VERIFY AFTER REPAIR PROCEDURE</b></p> <ul style="list-style-type: none"> <li>• Perform "AFTER REPAIR PROCEDURE"</li> </ul> <p>(See <b><u>AFTER REPAIR PROCEDURE [MZI-3.5].</u></b>)</p> <ul style="list-style-type: none"> <li>• Are any DTC present?</li> </ul>	Yes	Go to the applicable DTC inspection. (See <b><u>DTC TABLE [MZI-3.5].</u></b> )
		No	Troubleshooting completed.

### DTC P260F [MZI-3.5]

#### DTC P260F (MZI-3.5) DETECTION CONDITION AND POSSIBLE CAUSES

<b>DTC P260F</b>	<b>Evaporative emission system monitoring processor performance</b>
<b>DETECTION CONDITION</b>	<ul style="list-style-type: none"> <li>• This DTC sets when a concern is detected internal to the PCM. The microprocessor that controls the engine off natural vacuum (EONV) leak check monitor is separate from the main processor within the PCM.</li> </ul>
<b>POSSIBLE CAUSE</b>	<ul style="list-style-type: none"> <li>• Module communications network concerns</li> <li>• PCM calibration level</li> <li>• PCM malfunction</li> </ul>

#### DIAGNOSTIC PROCEDURE

#### DTC P260F (MZI-3.5) DIAGNOSTIC PROCEDURE

STEP	INSPECTION		ACTION
1	<p><b>VERIFY FREEZE FRAME DATA HAS BEEN RECORDED</b></p> <ul style="list-style-type: none"> <li>• Has FREEZE FRAME DATA been recorded?</li> </ul>	Yes	Go to the next step.
		No	Record FREEZE FRAME DATA on the repair order, then go to the next step.
2	<p><b>VERIFY RELATED REPAIR INFORMATION AVAILABILITY</b></p> <ul style="list-style-type: none"> <li>• Verify related Service Bulletins</li> </ul>	Yes	<p>Perform repair or diagnosis according to the available Service Bulletins.</p> <ul style="list-style-type: none"> <li>• If the vehicle is not repaired, go to</li> </ul>

## 2007 Mazda CX-9 Grand Touring

2007 ENGINE PERFORMANCE On-Board Diagnostic (MZI-3.5) - CX-9

	and/or on-line repair information availability.		the next step.
	<ul style="list-style-type: none"> <li>Is any related Service Bulletins available?</li> </ul>	No	Go to the next step.
3	<b>VERIFY RELATED PENDING CODE OR STORED DTCs</b> <ul style="list-style-type: none"> <li>Turn the ignition switch off then to the ON position (Engine off).</li> <li>Verify the related PENDING CODE or stored DTCs using the M-MDS.</li> </ul>	Yes	Go to the appropriate DTC troubleshooting. (See <b><u>DTC TABLE [MZI-3.5]</u></b> .)
		No	Go to the next step
4	<b>INSPECT THE PERFORMANCE OF THE PROCESSOR</b> <ul style="list-style-type: none"> <li>Turn the ignition switch off.</li> <li>Disconnect the battery and wait for <b>1 min</b> .</li> <li>Connect the battery.</li> <li>Start the engine and warm it up completely.</li> <li>Allow the engine idle to stabilize.</li> <li>Access FTP PID.</li> <li>Is the pressure equal to <b>0 kPa {0 kgf/cm<sup>2</sup> , 2.0 psi}</b> .</li> </ul>	Yes	Go to Step 6.
		No	Go to the next step.
5	<b>INSPECT FOR SELF-TEST DTC P260F</b> <ul style="list-style-type: none"> <li>Idle the engine <b>2 min</b> .</li> <li>Perform the KOEO/KOER self-test.</li> <li>Is DTC P260F present?</li> </ul>	Yes	Go to the next step.
		No	Troubleshooting completed.
6	<b>INSPECT PCM FOR THE LATEST CALIBRATION</b> <ul style="list-style-type: none"> <li>Program the PCM to the latest calibration.</li> <li>Turn the ignition switch to the ON position (Engine running).</li> <li>Idle the engine for <b>2 min</b> .</li> <li>Perform the KOEO/KOER self-test.</li> </ul>	Yes	Go to the next step.
		No	Troubleshooting completed.

## 2007 Mazda CX-9 Grand Touring

2007 ENGINE PERFORMANCE On-Board Diagnostic (MZI-3.5) - CX-9

	<ul style="list-style-type: none"> <li>• Is DTC P260F present?</li> </ul>		
7	<p><b>INSPECT FOR CORRECT PCM OPERATION</b></p> <ul style="list-style-type: none"> <li>• Disconnect all the PCM connectors.</li> <li>• Visually inspect for:                             <ul style="list-style-type: none"> <li>○ Pushed out pins</li> <li>○ Corrosion</li> </ul> </li> <li>• Connect all the PCM connectors and verify that they seat correctly.</li> <li>• Retrieve DTCs using the M-MDS.</li> <li>• Is the PENDING CODE for this DTC present?</li> </ul>	Yes	Go to the next step.
		No	The system is correctly. Go to the next step.
8	<p><b>VERIFY TROUBLESHOOTING OF DTC P260F HAS BEEN COMPLETED</b></p> <ul style="list-style-type: none"> <li>• Verify that all disconnected connectors reconnected.</li> <li>• Clear the DTC from the PCM memory using the M-MDS.</li> <li>• Perform the KOEO or KOER self-test using the M-MDS.</li> </ul> <p>(See <b><u>KOEO/KOER SELF TEST [MZI-3.5].</u></b>)</p> <ul style="list-style-type: none"> <li>• Is the PENDING CODE for the DTC present?</li> </ul>	Yes	Replace the PCM, then go to the next step. (see <b><u>PCM REMOVAL/INSTALLATION [MZI-3.5].</u></b> )
		No	Go to the next step.
9	<p><b>VERIFY AFTER REPAIR PROCEDURE</b></p> <ul style="list-style-type: none"> <li>• Perform "AFTER REPAIR PROCEDURE".</li> </ul> <p>(See <b><u>AFTER REPAIR PROCEDURE [MZI-3.5].</u></b>)</p> <ul style="list-style-type: none"> <li>• Are any DTCs present?</li> </ul>	Yes	Go to the applicable DTC inspection. (See <b><u>DTC TABLE [MZI-3.5].</u></b> )
		No	Troubleshooting completed.