

**2008 Mazda CX-9 Grand Touring**

2008 ACCESSORIES & BODY, CAB Exterior Trim - Mazda CX-9

**2008 ACCESSORIES & BODY, CAB**

**Exterior Trim - Mazda CX-9**

**EXTERIOR TRIM LOCATION INDEX**

## 2008 Mazda CX-9 Grand Touring

### 2008 ACCESSORIES & BODY, CAB Exterior Trim - Mazda CX-9

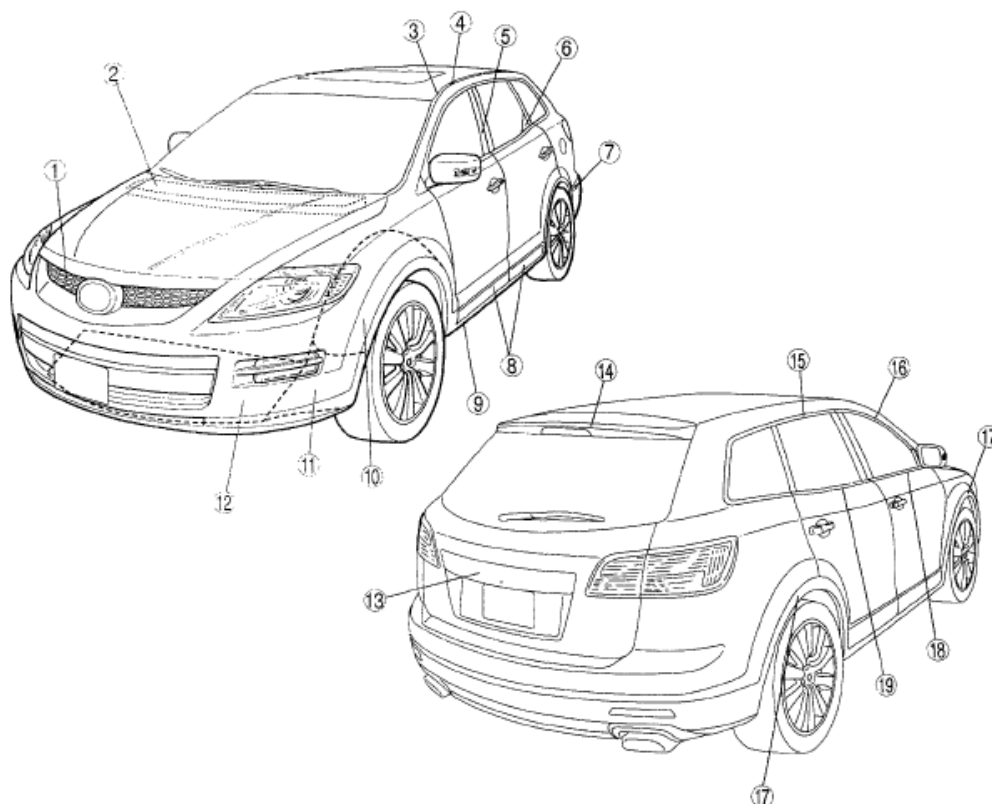

ac9uuw00001046

1	Radiator grille (See 09-16-3 RADIATOR GRILLE REMOVAL/ INSTALLATION.)
2	Cowl grille (See 09-16-4 COWL GRILLE REMOVAL/ INSTALLATION.)
3	Roof molding (See 09-16-7 ROOF MOLDING REMOVAL.) (See 09-16-7 ROOF MOLDING INSTALLATION.)
4	Roof carrier bracket (See 09-16-8 ROOF CARRIER BRACKET REMOVAL/INSTALLATION.)
5	Door sash film (See 09-16-17 DOOR SASH FILM REMOVAL.) (See 09-16-18 DOOR SASH FILM INSTALLATION.)
6	Rear door garnish (See 09-16-11 REAR DOOR GARNISH REMOVAL/ INSTALLATION.)
7	Extractor chamber (See 09-16-20 EXTRACTOR CHAMBER REMOVAL/INSTALLATION.)
8	Side garnish (See 09-16-14 SIDE GARNISH REMOVAL.) (See 09-16-15 SIDE GARNISH INSTALLATION.)
9	Side step molding (See 09-16-15 SIDE STEP MOLDING REMOVAL.) (See 09-16-16 SIDE STEP MOLDING INSTALLATION.)
10	Splash board (See 09-16-13 SPLASH SHIELD REMOVAL/ INSTALLATION.)
11	Front under cover B (See 09-16-13 FRONT UNDER COVER REMOVAL/ INSTALLATION.)

12	Front under cover A (See 09-16-13 FRONT UNDER COVER REMOVAL/ INSTALLATION.)
13	Rear finisher (See 09-16-9 REAR FINISHER REMOVAL/ INSTALLATION.)
14	Rear spoiler (See 09-16-11 REAR SPOILER REMOVAL/ INSTALLATION.)
15	Rear sash molding (See 09-16-20 REAR SASH MOLDING REMOVAL.) (See 09-16-10 REAR SASH MOLDING INSTALLATION.)
16	Front sash molding (See 09-16-16 FRONT SASH MOLDING REMOVAL.) (See 09-16-17 FRONT SASH MOLDING INSTALLATION.)
17	Over fender (See 09-16-12 OVER FENDER REMOVAL/ INSTALLATION.)
18	Front beltline molding (See 09-16-5 FRONT BELTLINE MOLDING REMOVAL/INSTALLATION.)
19	Rear beltline molding (See 09-16-6 REAR BELTLINE MOLDING REMOVAL/INSTALLATION.)

**Fig. 1: Identifying Exterior Trim Location**

Courtesy of MAZDA MOTORS CORP.

**RADIATOR GRILLE REMOVAL/INSTALLATION**

1. Set the front over fender out of the way. (See **OVER FENDER REMOVAL/INSTALLATION.**)
2. Remove the front bumper. (See **FRONT BUMPER REMOVAL/INSTALLATION .**)
3. Remove the bolts.

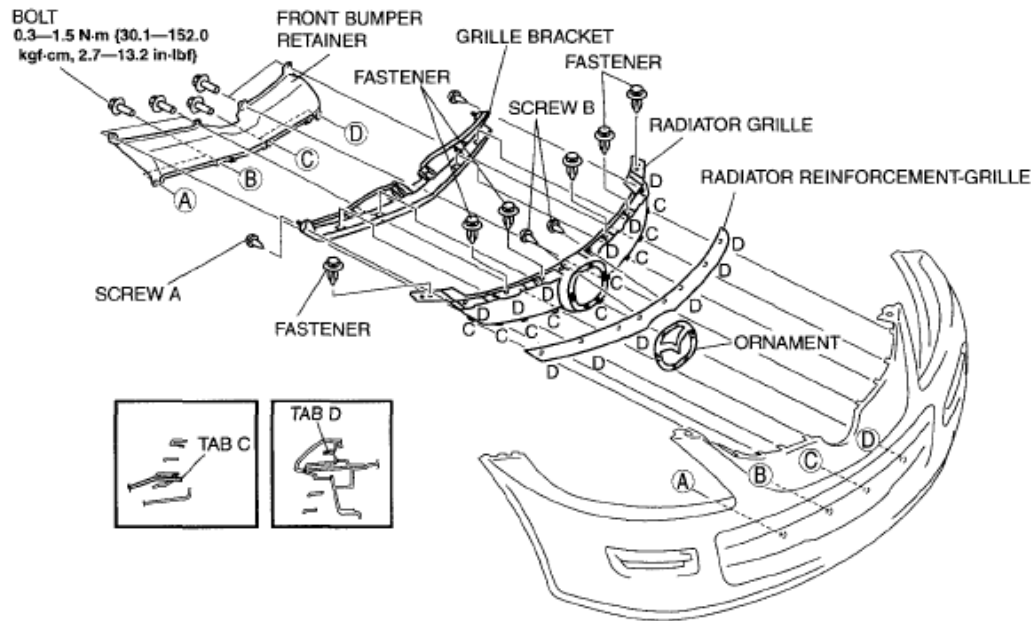

**Fig. 2: Identifying Radiator Grille Components & Torque Specifications**

Courtesy of MAZDA MOTORS CORP.

4. Remove the front bumper retainers.
5. Remove the fasteners.
6. Remove the screws A.
7. Remove the grille bracket.
8. Remove the screws B.
9. Remove the tabs D.
10. Remove the ornament.
11. Remove the radiator grille.
12. Press tabs C in the direction of the arrow, pull the radiator grille inward, and remove it from the front bumper.
13. Install in the reverse order of removal.

**COWL GRILLE REMOVAL/INSTALLATION**

1. Remove the windshield wiper arm and blade. (See **WINDSHIELD WIPER ARM AND BLADE REMOVAL/INSTALLATION** .)
2. Remove the front fender molding.

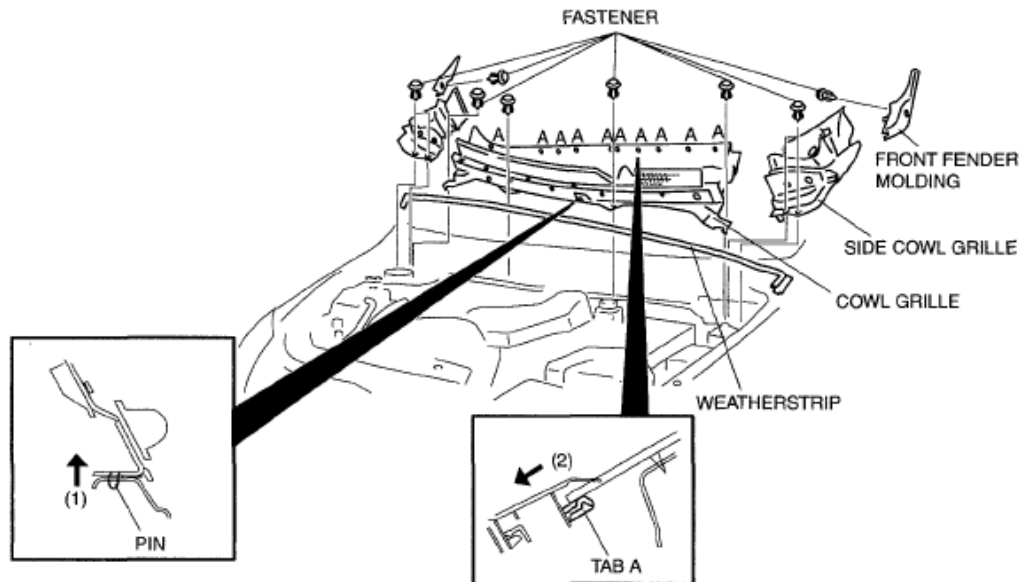

ac9uuw00000825

**Fig. 3: Identifying Cowl Grille Components**  
 Courtesy of MAZDA MOTORS CORP.

3. Remove the weatherstrip.
4. Remove the fastener.
5. Remove the side cowl grille.
6. Pull the cowl grille in the direction of arrow (1) so that it is free from the pins, pull tabs A in the direction of arrow (2), and then remove the windshield.
7. Disconnect the windshield washer hose.
8. Remove the cowl grille.
9. Install in the reverse order of removal. joint pipe

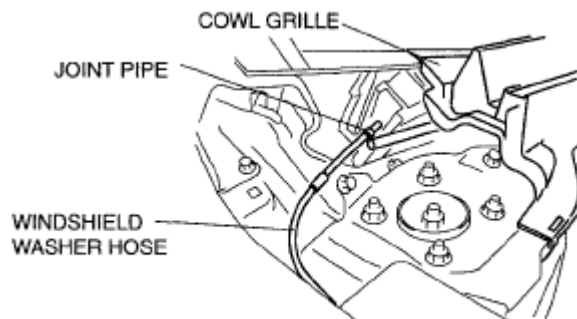

ac9uuw00001176

**Fig. 4: Identifying Cowl Grille, Windshield Washer Hose And Joint Pipe**  
 Courtesy of MAZDA MOTORS CORP.

## FRONT BELTLINE MOLDING REMOVAL/INSTALLATION

### REMOVAL

1. Fully open the front door glass.
2. Disconnect the negative battery cable.
3. Remove the inner garnish. (See **INNER GARNISH REMOVAL/INSTALLATION** .)
4. Remove the front door trim. (See **FRONT DOOR TRIM REMOVAL/INSTALLATION** .)
5. Remove the power outer mirror. (See **POWER OUTER MIRROR REMOVAL/INSTALLATION** .)
6. Remove clip A using a protective tape-wrapped flathead screwdriver.
7. Lift (partially peeling back) the front beltline molding in the direction of the arrow and then remove tabs B.
8. Remove the clip C.
9. Remove the front beltline molding.

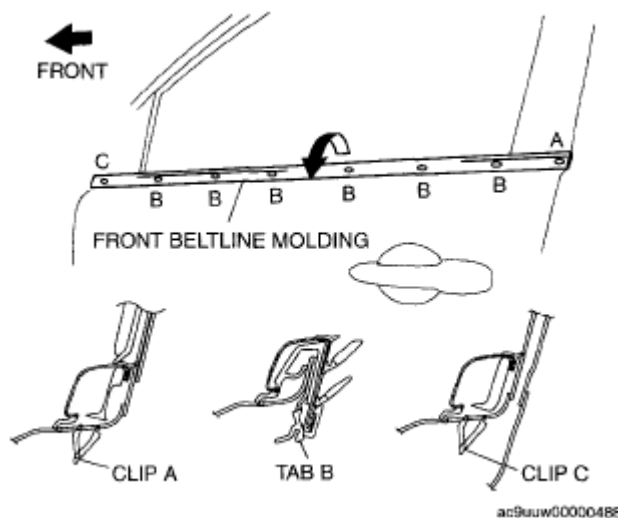
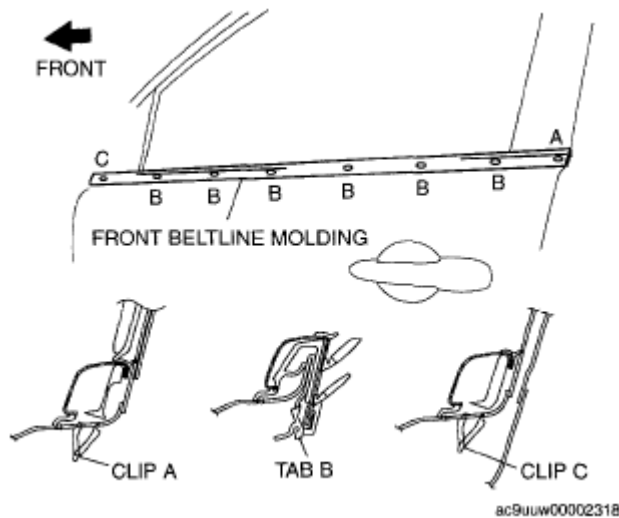

**Fig. 5: Identifying Front Beltline Molding With Clips And Tab**  
 Courtesy of MAZDA MOTORS CORP.

### INSTALLATION

1. Install the clip A.
2. Install the tabs B.
3. Install the clip C.
4. Install the front beltline molding.
5. Install the power outer mirror. (See **POWER OUTER MIRROR REMOVAL/INSTALLATION** .)

6. Install the front door trim. (See **FRONT DOOR TRIM REMOVAL/INSTALLATION** .)
7. Install the inner garnish. (See **INNER GARNISH REMOVAL/INSTALLATION** .)
8. Connect the negative battery cable.

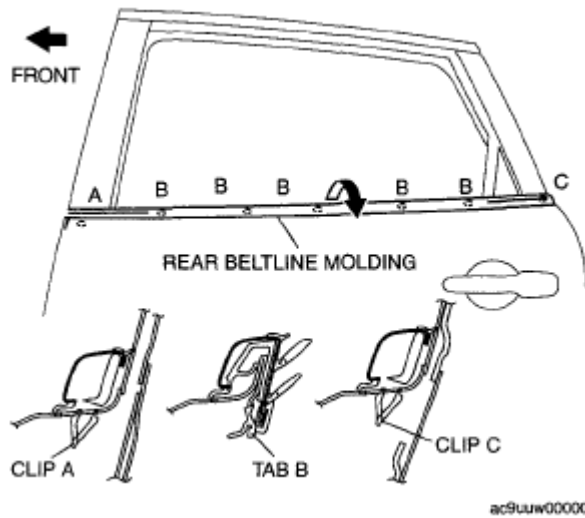

**Fig. 6: Identifying Front Beltline Molding With Clips And Tab**  
Courtesy of MAZDA MOTORS CORP.

## REAR BELTLINE MOLDING REMOVAL/INSTALLATION

### REMOVAL

1. Fully lower the rear door glass.
2. Remove the clip A using a protective tape-wrapped flathead screwdriver.
3. Lift (partially peeling back) the rear beltline molding in the direction of the arrow and then remove tabs B.
4. Remove the clip C.
5. Remove the rear beltline molding.



**Fig. 7: Identifying Rear Beltline Molding With Clips And Tab**  
Courtesy of MAZDA MOTORS CORP.

## INSTALLATION

1. Install the clip A.
2. Install the tabs B.
3. Install the clip C.
4. Install the rear beltline molding.

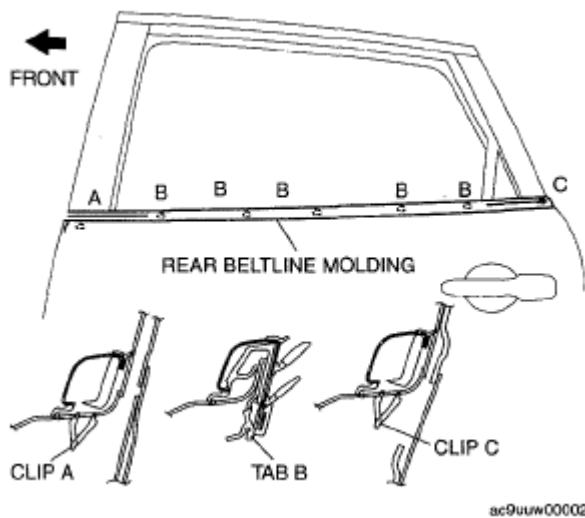

**Fig. 8: Identifying Rear Beltline Molding With Clips And Tab**  
Courtesy of MAZDA MOTORS CORP.

## ROOF MOLDING REMOVAL

1. Detach the T-stud which secure sections A of roof molding, using a flat head screwdriver or equivalent tool.
2. While pulling the roof molding up, detach it from the clips at section B, C, and then remove the roof molding.

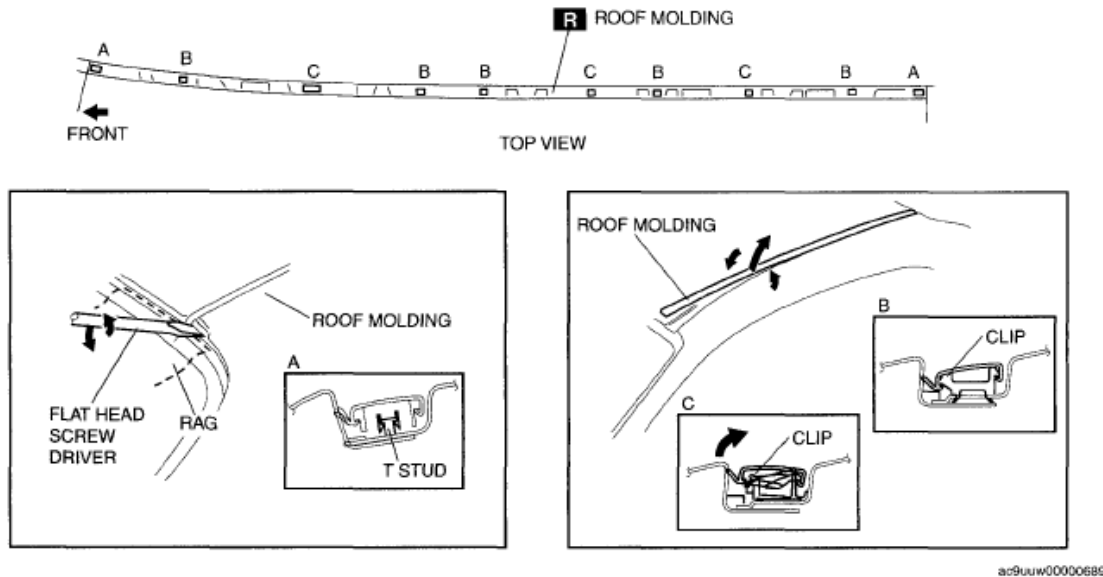

**Fig. 9: Identifying Roof Molding With T-Stud And Clips**  
 Courtesy of MAZDA MOTORS CORP.

## ROOF MOLDING INSTALLATION

1. Attach the roof molding to the T-stud at the front portion of section A.
2. Hook the roof molding to clips B, C and press it in to attach.
3. Attach the roof molding to the T-stud at the rear portion of section A.

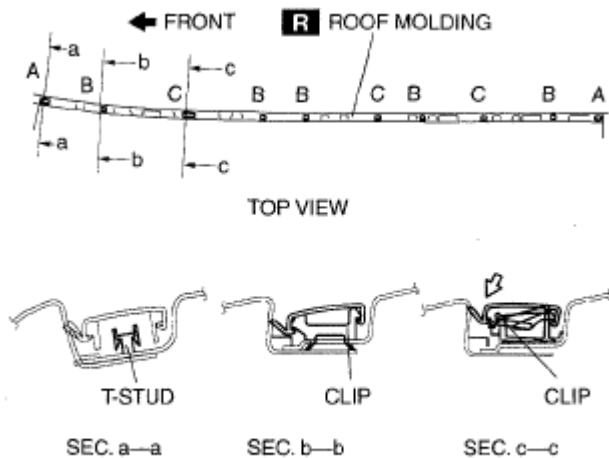



**Fig. 10: Identifying Roof Molding With T-Stud And Clips**  
Courtesy of MAZDA MOTORS CORP.

## ROOF CARRIER BRACKET REMOVAL/INSTALLATION

1. Disconnect the negative battery cable.
2. Partially peel back the seaming welt.
3. Remove the following parts:
  1. A-pillar trim (See **A-PILLAR TRIM REMOVAL/INSTALLATION** .)
  2. Front scuff plate inner (See **FRONT SCUFF PLATE REMOVAL/INSTALLATION** .)
  3. Rear scuff plate inner (See **REAR SCUFF PLATE REMOVAL/INSTALLATION** .)
  4. Front seat belt lower anchor installation bolt (Driver side) (See **FRONT SEAT BELT REMOVAL/INSTALLATION** .)
  5. B-pillar lower trim (See **B-PILLAR LOWER TRIM REMOVAL/INSTALLATION** .)
  6. Front seat belt upper anchor installation bolt (See **FRONT SEAT BELT REMOVAL/INSTALLATION** .)
  7. B-pillar upper trim (See **B-PILLAR UPPER TRIM REMOVAL/INSTALLATION** .)
  8. Trunk box (See **TRUNK BOX REMOVAL/INSTALLATION** .)
  9. Seat side box (See **SEAT SIDE BOX REMOVAL/INSTALLATION** .)
  10. Trunk end trim (See **TRUNK END TRIM REMOVAL/INSTALLATION** .)
  11. Third-row seat (See **THIRD-ROW SEAT REMOVAL/INSTALLATION** .)
  12. Third-row seat belt lower anchor installation bolt (See **THIRD-ROW SEAT BELT REMOVAL/INSTALLATION** .)
  13. Trunk side trim (See **TRUNK SIDE TRIM REMOVAL/INSTALLATION** .)
  14. Roof side trim (See **ROOF SIDE TRIM REMOVAL/INSTALLATION** .)
  15. Second-row seat belt upper anchor installation bolt (See **SECOND-ROW SEAT BELT REMOVAL/INSTALLATION** .)
  16. C-pillar trim (See **C-PILLAR TRIM REMOVAL/INSTALLATION** .)
  17. Third-row seat belt upper anchor installation bolt (See **THIRD-ROW SEAT BELT REMOVAL/INSTALLATION** .)
  18. D-pillar trim (See **D-PILLAR TRIM REMOVAL/INSTALLATION** .)
  19. Front map light (See **FRONT MAP LIGHT REMOVAL/INSTALLATION** .)
  20. Sunvisor (See **SUNVISOR REMOVAL/INSTALLATION** .)
  21. Assist handle (See **ASSIST HANDLE REMOVAL/INSTALLATION** .)
  22. Headliner (See **HEADLINER REMOVAL/INSTALLATION** .)
4. Remove the nuts.
5. Remove the roof carrier bracket.
6. Install in the reverse order of removal.

**NOTE:**

- Install the roof carrier bracket so that the arrow on it faces inward.

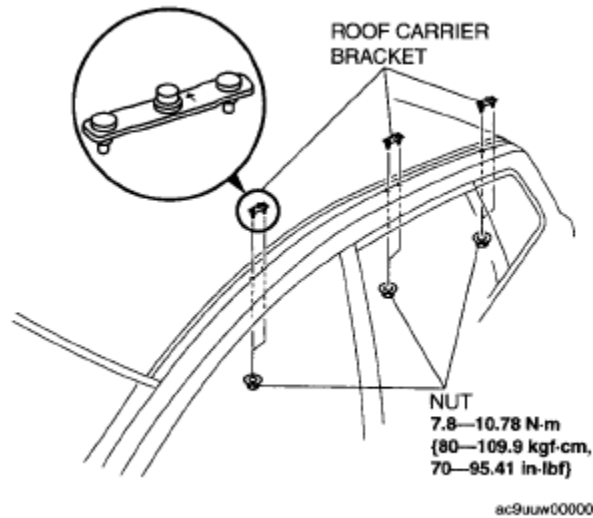

**Fig. 11: Identifying Roof Carrier Bracket With Nuts & Torque Specifications**  
 Courtesy of MAZDA MOTORS CORP.

**REAR FINISHER REMOVAL/INSTALLATION**

1. Remove the liftgate upper trim. (See LIFTGATE UPPER TRIM REMOVAL/INSTALLATION )
2. Remove the liftgate side trim. (See LIFTGATE SIDE TRIM REMOVAL/INSTALLATION )
3. Remove the liftgate lower trim. (See LIFTGATE LOWER TRIM REMOVAL/INSTALLATION .)
4. Set the noise filter out of the way. (See NOISE FILTER REMOVAL/INSTALLATION .)
5. Remove the bolts.
6. Remove the dynamic damper.

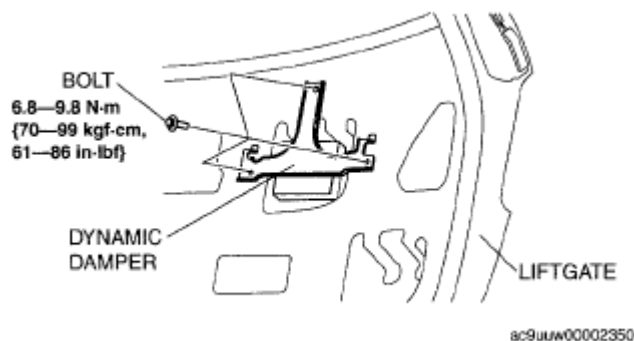

**Fig. 12: Identifying Dynamic Damper With Bolts & Torque Specifications**  
 Courtesy of MAZDA MOTORS CORP.

7. Disconnect the request switch connector and the rear mount camera connector.

8. Remove the nuts.
9. Pull the rear finisher outward, then disengage clip A, B, and C from the body.
10. Remove the rear finisher.
11. Remove the request switch. (See **REQUEST SWITCH REMOVAL/INSTALLATION [ADVANCED KEYLESS SYSTEM]** .)(Vehicles with advanced keyless system)
12. Remove the rear mount camera. (See **REAR MOUNT CAMERA REMOVAL/INSTALLATION** .) (Vehicles with rear mount camera)
13. Install in the reverse order of removal.

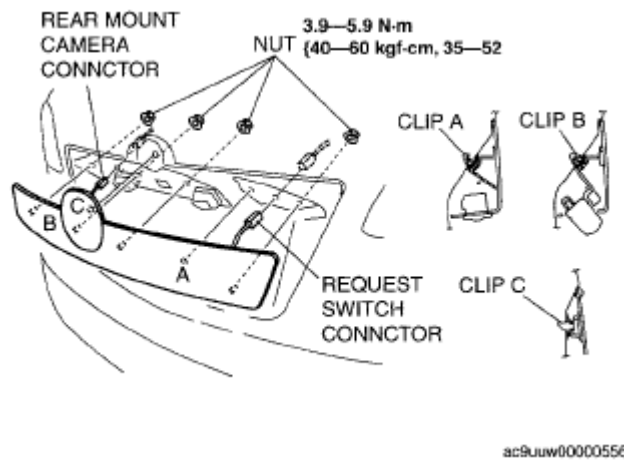

**Fig. 13: Identifying Request Switch Connector, Rear Mount Camera Connector & Torque Specifications**  
 Courtesy of MAZDA MOTORS CORP.

## REAR SASH MOLDING INSTALLATION

**NOTE:**

- Double-sided adhesive tape has already been attached to the new rear sash molding.

**WARNING:**

- Using a razor with bare hands can cause injury. Always wear gloves when using a razor.

1. When installing a new rear sash molding, follow the procedure below:
  1. Remove the adhesive remaining on the body using razor.
  2. Remove any grease or dirt from the adhesion surface of the body.
2. When reusing the rear sash molding, follow the procedure below:
  1. Remove the adhesive remaining on the rear sash molding and the body using a razor.
  2. Remove any grease or dirt from the adhesion surface of the rear sash molding and the body.
  3. Apply primer to the bonding area of the rear sash molding.

- Affix double-sided adhesive tape A to the rear sash molding as shown in the figure.

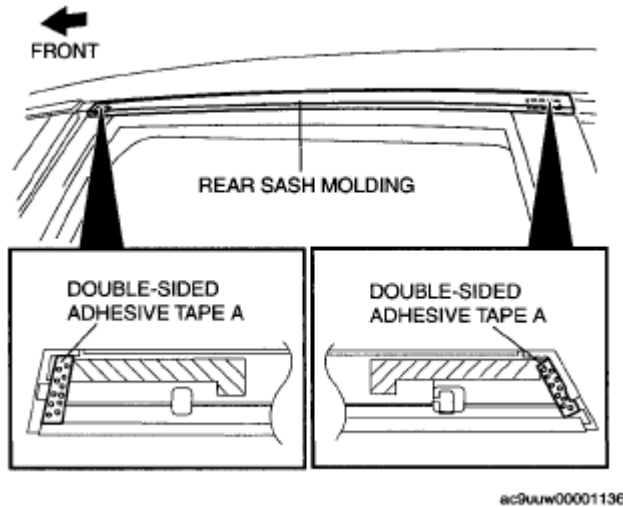

**Fig. 14: Identifying Double-Sided Adhesive Tape Applying To Rear Sash Molding**  
 Courtesy of MAZDA MOTORS CORP.

- Affix double-sided adhesive tape B to the rear sash molding as shown in the figure.

**NOTE:**

- As for the double-sided adhesive tape, use beta tape B 5078 (1 mm {0.04 in} thickness) or equivalent.

- Peel off the backing of the double-sided

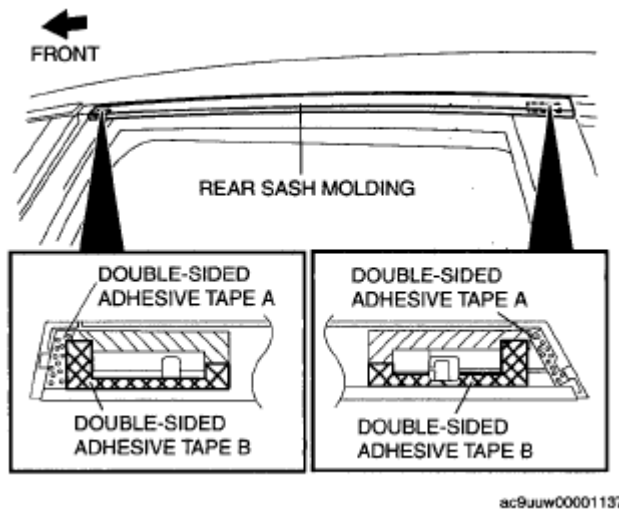

**Fig. 15: Identifying Double-Sided Adhesive Tape Applying To Rear Sash Molding**  
 Courtesy of MAZDA MOTORS CORP.

- Hook tab B to the body in the position where tabs A and D align with the sash holes.

- Press the rear sash molding in the direction of the arrow and install tabs A and D to the body.

**CAUTION:**

- Do not press the rear sash molding in any place other than the rubber areas.

- Press the rear sash molding from the vehicle front in the direction of the arrow and install tab C.

**NOTE:**

- After installing the front sash molding, verify that tabs B and C are connected properly to the body.

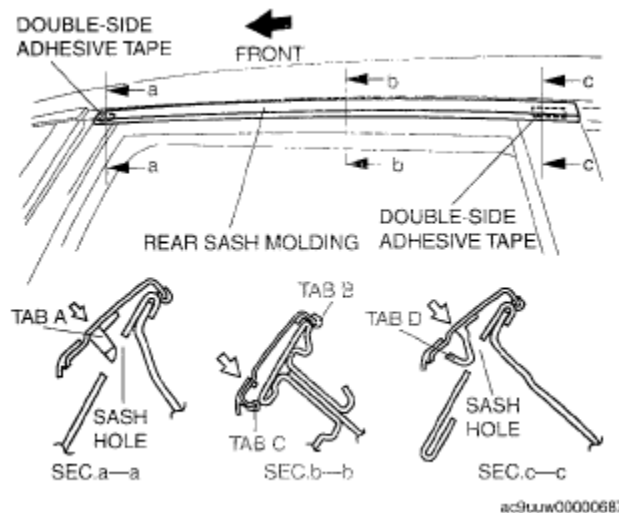

**Fig. 16: Identifying Double-Sided Adhesive Tape And Rear Sash Molding**  
 Courtesy of MAZDA MOTORS CORP.

## REAR SPOILER REMOVAL/INSTALLATION

- Disconnect the negative battery cable.
- Remove the liftgate upper trim. (See LIFTGATE UPPER TRIM REMOVAL/INSTALLATION .)
- Disconnect the high-mount brake light connector.
- Remove the nuts.
- Detach the clips and remove the rear spoiler.
- Install in the reverse order of removal.

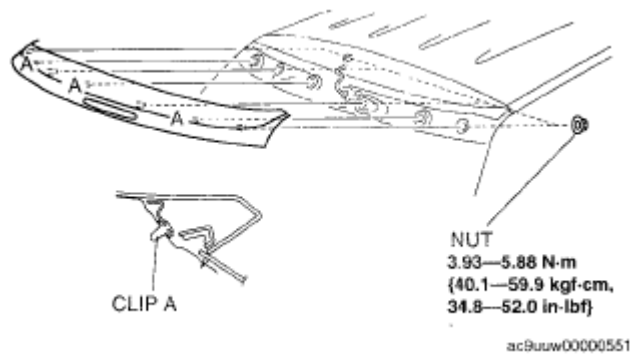

**Fig. 17: Identifying Rear Spoiler With Nut, Clip & Torque Specifications**  
 Courtesy of MAZDA MOTORS CORP.

## REAR DOOR GARNISH REMOVAL/INSTALLATION

1. Remove the inner sail garnish. (See INNER SAIL GARNISH REMOVAL/INSTALLATION .)
2. Remove the screws.
3. Remove the pin A.
4. Slide the rear door garnish in the direction shown by the arrow and remove it.
5. Install in the reverse order of removal.



**Fig. 18: Identifying Rear Door Garnish With Screw**  
 Courtesy of MAZDA MOTORS CORP.

## OVER FENDER REMOVAL/INSTALLATION

### FRONT

1. Remove the fasteners.
2. Remove the clips A.
3. Remove the clip B.
4. Remove the clip C.
5. Remove the front over fender.

6. Install in the reverse order of removal.

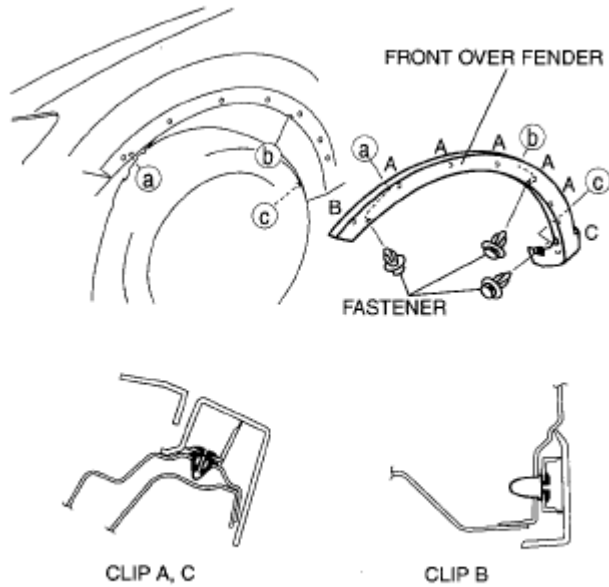

ac9uuw00000724

**Fig. 19: Identifying Front Over Fender With Clips**  
Courtesy of MAZDA MOTORS CORP.

## REAR

1. Remove the fastener.
2. Remove the clips A.
3. Remove the clips B.
4. Remove the clip C.
5. Remove the rear over fender.
6. Install in the reverse order of removal.

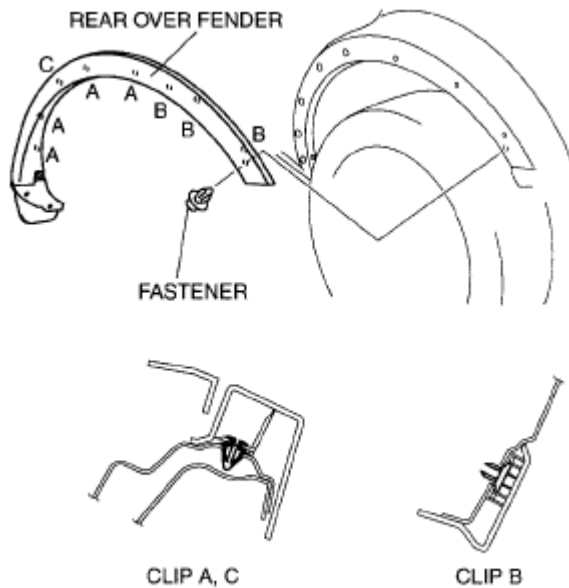

ac9uuw00000725

**Fig. 20: Identifying Rear Over Fender With Clips**  
Courtesy of MAZDA MOTORS CORP.

## FRONT UNDER COVER REMOVAL/INSTALLATION

### FRONT UNDER COVER A

1. Remove the bolts.
2. Remove the screws.
3. Remove the front under cover A.
4. Install in the reverse order of removal.

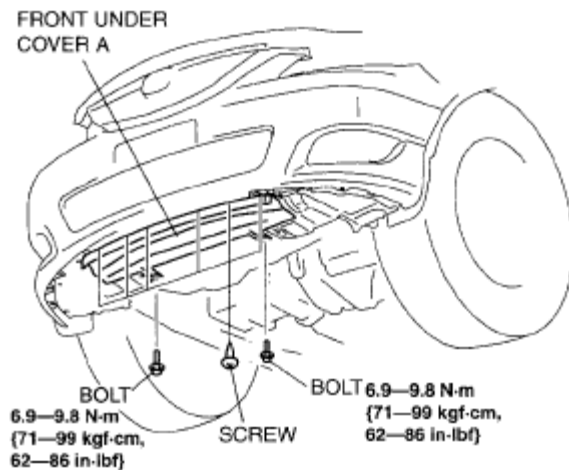

ac9uuw00000822



**Fig. 21: Identifying Front Under Cover A With Screws, Bolts & Torque Specifications**  
Courtesy of MAZDA MOTORS CORP.

## FRONT UNDER COVER B

1. Remove the screws.
2. Remove the fasteners.
3. Remove the front under cover B.
4. Install in the reverse order of removal.

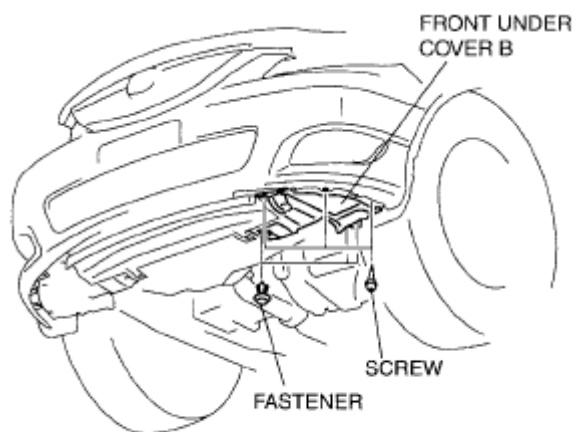

ac9uuw00000623

**Fig. 22: Identifying Front Under Cover B With Screws And Bolts**  
Courtesy of MAZDA MOTORS CORP.

## SPLASH SHIELD REMOVAL/INSTALLATION

1. Remove the front over fender. (See OVER FENDER REMOVAL/INSTALLATION.)
2. Remove the bolts.
3. Remove the fasteners A.
4. Remove the splash shield.
5. Install in the reverse order of removal.

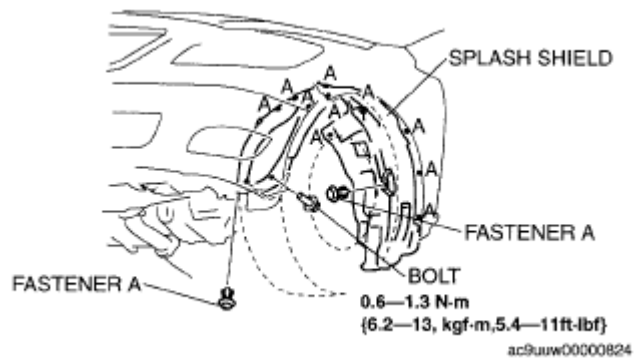

**Fig. 23: Identifying Splash Shield, Fasteners & Torque Specifications**  
Courtesy of MAZDA MOTORS CORP.

## SAIL GARNISH REMOVAL/INSTALLATION

1. Pull the sail garnish outward and detach clips A from the body.
2. Remove the sail garnish.
3. Install in the reverse order of removal.

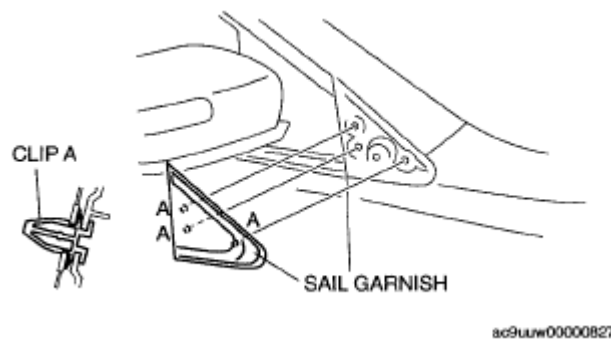
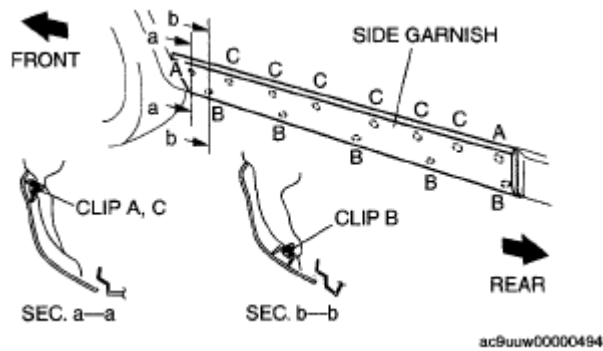

**Fig. 24: Identifying Sail Garnish With Clips**  
Courtesy of MAZDA MOTORS CORP.

## SIDE GARNISH REMOVAL

### FRONT

1. Pull the side garnish and remove clip A from the vehicle body.
2. Slide the side garnish to the vehicle rear and remove clips B and C from the side garnish.
3. Remove the side garnish.
4. Remove clips B and C from the body, then install it to the side garnish.



**Fig. 25: Identifying Front Side Garnish With Clips**  
 Courtesy of MAZDA MOTORS CORP.

**REAR**

1. Pull the side garnish and remove clip A from the vehicle body.
2. Slide the side garnish to the vehicle rear and remove clips B and C from the side garnish.
3. Remove the side garnish.
4. Remove clips B and C from the body, then install it to the side garnish.

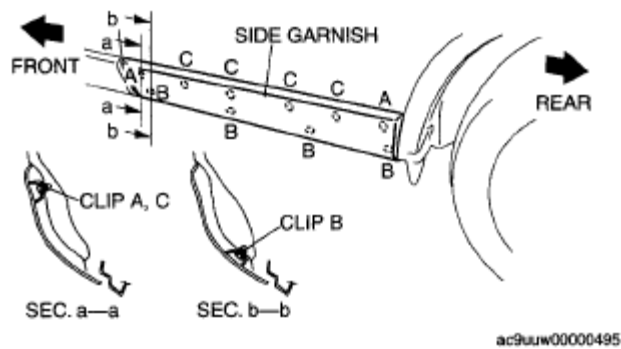
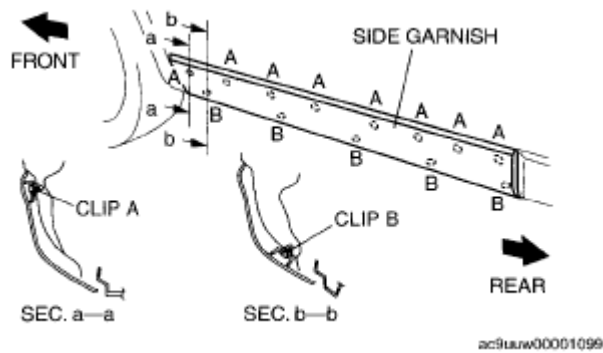

**Fig. 26: Identifying Rear Side Garnish With Clips**  
 Courtesy of MAZDA MOTORS CORP.

**SIDE GARNISH INSTALLATION**

**FRONT**

1. Install clips A and then B to the vehicle from the front side.



**Fig. 27: Identifying Front Side Garnish With Clips**  
 Courtesy of MAZDA MOTORS CORP.

**REAR**

1. Install clips A and then B to the vehicle from the rear side.

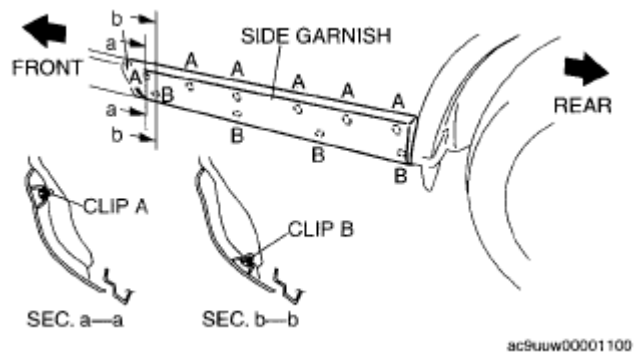

**Fig. 28: Identifying Rear Side Garnish With Clips**  
 Courtesy of MAZDA MOTORS CORP.

**SIDE STEP MOLDING REMOVAL**

1. Set the over fender out of the way
2. Remove the tow fasteners shown in the figure and set the front over fender out of the way.
3. Slide the side step molding in the direction of the arrow and detach clips A and B.
4. Remove the side step molding.
5. Remove clips A and B from the body, then install it to the side step molding.

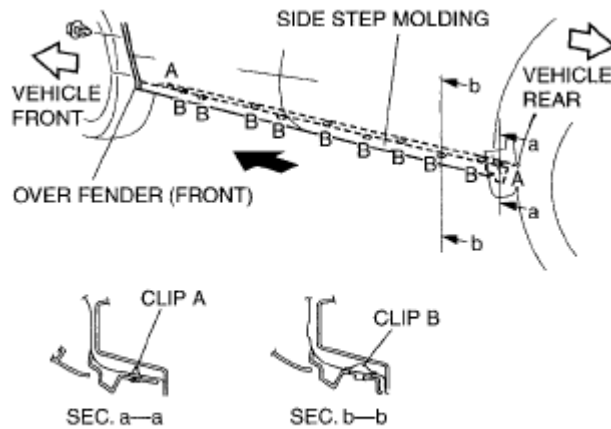

ac9uuw00002338

**Fig. 29: Identifying Side Step Molding With Clips**  
Courtesy of MAZDA MOTORS CORP.

## SIDE STEP MOLDING INSTALLATION

1. Install the clips A and B.
2. Return the over fender to its original position.

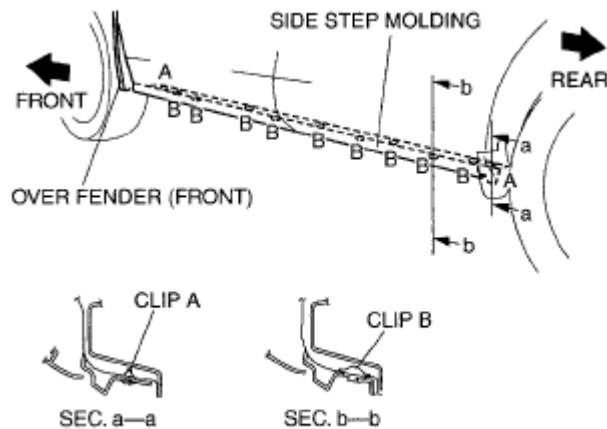

ac9uuw00001112

**Fig. 30: Identifying Side Step Molding With Clips**  
Courtesy of MAZDA MOTORS CORP.

## FRONT SASH MOLDING REMOVAL

- WARNING:**
- Using a razor with bare hands can cause injury. Always wear gloves when using a razor.

1. Remove the power outer mirror. (See **POWER OUTER MIRROR REMOVAL/INSTALLATION**.)

2. Press tab A in the direction of the arrow and remove it.
3. While cutting the double-sided adhesive tape using a flathead screwdriver or a razor, separate the front sash molding from the body.
4. Rotate the front sash molding at the pivot of tab B in the direction of arrow D and remove it.
5. Remove the tab C.
6. Remove the front sash molding.

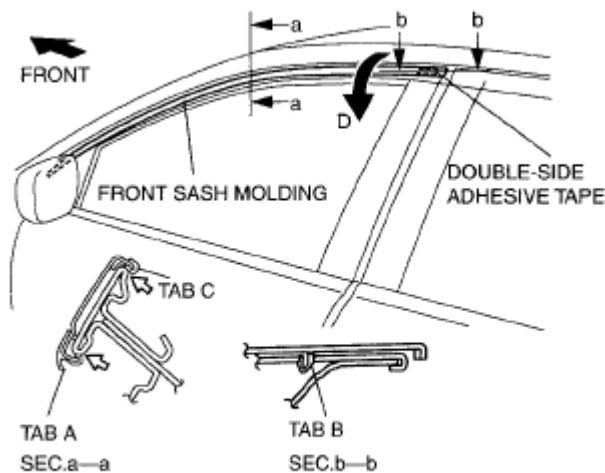

ac9uuw00002048

**Fig. 31: Identifying Front Sash Molding With Tab**  
 Courtesy of MAZDA MOTORS CORP.

## DOOR SASH FILM REMOVAL

1. Partially peel back the glass run channel.
2. Partially peel back the door weatherstrip.
3. Remove the following parts:
  1. Inner garnish (See [INNER GARNISH REMOVAL/INSTALLATION](#) .)
  2. Front door trim (See [FRONT DOOR TRIM REMOVAL/INSTALLATION](#) .)
  3. Inner sail garnish (See [INNER SAIL GARNISH REMOVAL/INSTALLATION](#) .)
  4. Rear door trim (See [REAR DOOR TRIM REMOVAL/INSTALLATION](#) .)
  5. Front beltline molding (See [FRONT BELTLINE MOLDING REMOVAL/INSTALLATION](#).)
  6. Rear beltline molding (See [REAR BELTLINE MOLDING REMOVAL/INSTALLATION](#).)
  7. Front sash molding (See [FRONT SASH MOLDING REMOVAL](#).)
  8. Rear sash molding (See [REAR SASH MOLDING REMOVAL](#).)
  9. Rear door garnish (See [REAR DOOR GARNISH REMOVAL/INSTALLATION](#).)
4. Peel off the rear sash film by pulling it outward from one end.

**NOTE:**

- Slowly remove the door sash film since it may tear easily.

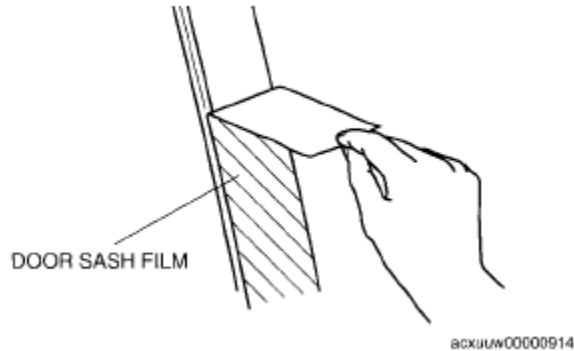

**Fig. 32: Peeling Off Rear Sash Film**  
Courtesy of MAZDA MOTORS CORP.

## FRONT SASH MOLDING INSTALLATION

**NOTE:**

- Double-sided adhesive tape has already been attached to the new front sash molding.

**WARNING:**

- Using a razor with bare hands can cause injury. Always wear gloves when using a razor.

1. When installing a new front sash molding, follow the procedure below:
  1. Remove the adhesive remaining on the body using razor.
  2. Remove any grease or dirt from the adhesion surface of the body.
2. When reusing the front sash molding, follow the procedure below:
  1. Remove the adhesive remaining on the front sash molding and the body using a razor.
  2. Remove any grease or dirt from the adhesion surface of the front sash molding and the body.
  3. Apply primer to the bonding area of the front sash molding.
  4. Affix double-sided adhesive tape A to the front sash molding as shown in the figure.

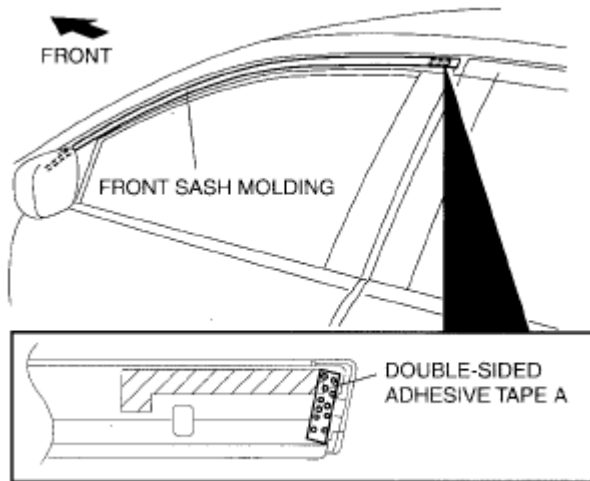

ac9uuw0000477

**Fig. 33: Identifying Double-Sided Adhesive Tape Applyin To Front Sash Molding**  
Courtesy of MAZDA MOTORS CORP.

5. Affix double-sided adhesive tape B to the front sash molding as shown in the figure.

**NOTE:**

- As for the double-sided adhesive tape, use beta tape 5078 (1 mm {0.04 in} thickness) or equivalent.

3. Peel off the backing of the double-sided adhesive tape.

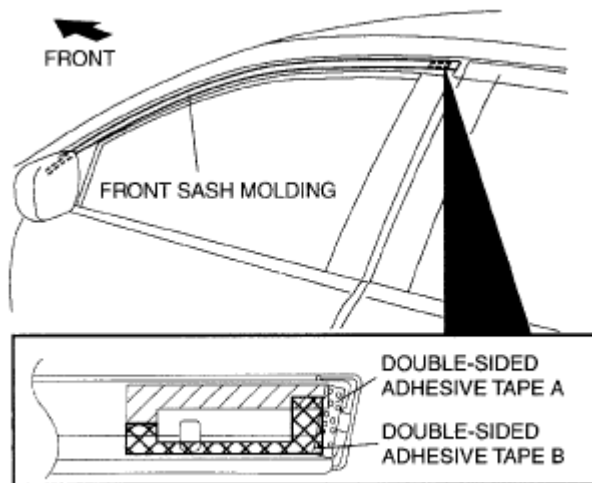

ac9uuw00001141

**Fig. 34: Identifying Double-Sided Adhesive Tape Applying To Front Sash Molding**  
Courtesy of MAZDA MOTORS CORP.

4. Hook tab A to the body in the position where tabs B align with the sash holes.
5. Press the front sash molding in the direction of the arrow and install tabs B to the body.



- CAUTION:**
- Do not press the front sash molding in any place other than the rubber areas.

6. Press the front sash molding from the vehicle rear in the direction shown in the arrow and install tab C.

- NOTE:**
- After installing the front sash molding, verify that tabs A and B are connected properly to the body.

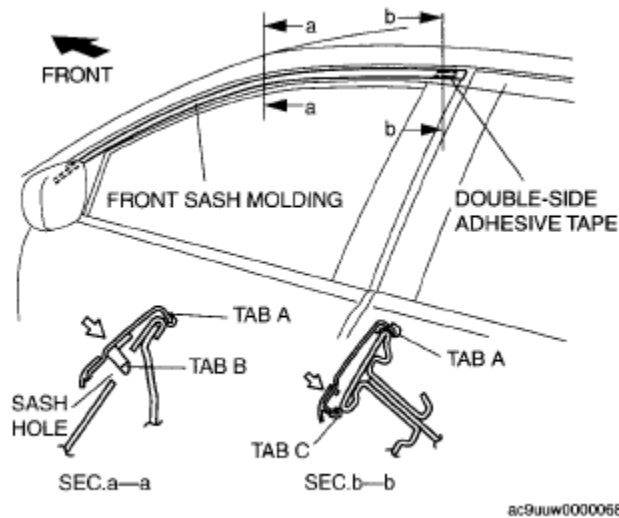

**Fig. 35: Identifying Double-Sided Adhesive Tape And Front Sash Molding**  
 Courtesy of MAZDA MOTORS CORP.

## DOOR SASH FILM INSTALLATION

1. Remove any grease or dirt from the affixing surface of the door.
2. Cut away the unused portion along the dotted lines.

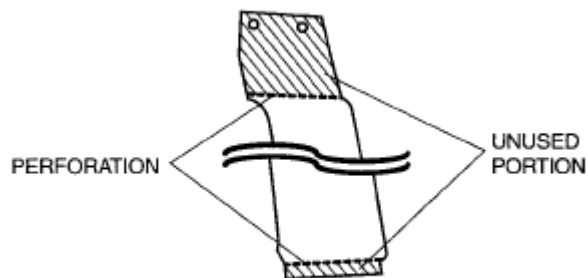

ac9uuw0000915

**Fig. 36: Identifying Door Sash Film Area**  
 Courtesy of MAZDA MOTORS CORP.

3. Peel off the backing paper and attach the door sash film onto the door as shown in the figure.

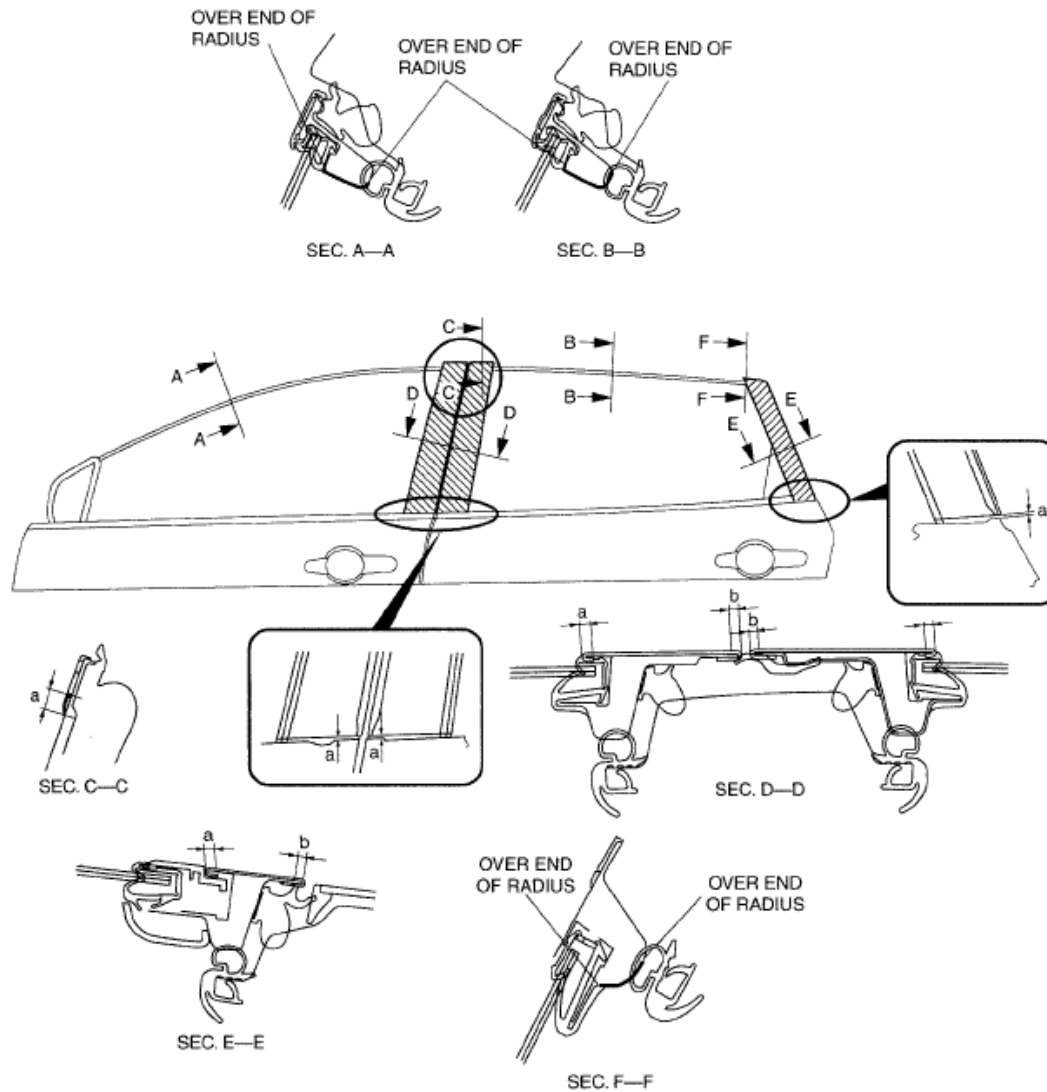

ac9uuw00000487

**Fig. 37: Attaching Door Sash Film Onto Door**  
 Courtesy of MAZDA MOTORS CORP.

**Standard clearance**

**a: 2.0 mm or more {0.08 in or more}**

**b: 3.0-5.0 mm {0.12-0.19 in}**

4. Peel off the transparent protective film on the door sash film.
5. Install the following parts:
  1. Rear door garnish (See **REAR DOOR GARNISH REMOVAL/INSTALLATION.**)

2. Rear sash molding (See REAR SASH MOLDING INSTALLATION.)
3. Front sash molding (See FRONT SASH MOLDING INSTALLATION.)
4. Rear beltline molding (See REAR BELTLINE MOLDING REMOVAL/INSTALLATION.)
5. Front beltline molding (See FRONT BELTLINE MOLDING REMOVAL/INSTALLATION.)
6. Rear door trim (See REAR DOOR TRIM REMOVAL/INSTALLATION .)
7. Inner sail garnish (See INNER SAIL GARNISH REMOVAL/INSTALLATION .)
8. Front door trim (See FRONT DOOR TRIM REMOVAL/INSTALLATION .)
9. Inner garnish (See INNER GARNISH REMOVAL/INSTALLATION .)

## REAR SASH MOLDING REMOVAL

**WARNING:** • Using a razor with bare hands can cause injury. Always wear gloves when using a razor.

1. Press tab C in the direction of the arrow and remove it.
2. While cutting the double-sided adhesive tape using a flathead screwdriver or a razor, separate the rear sash molding from the body.
3. Remove the tab D.
4. Rotate the rear sash molding in the direction of the arrow and remove tab A.
5. Rotate the rear sash molding in the direction of the arrow and remove tab B.
6. Remove the rear sash molding.

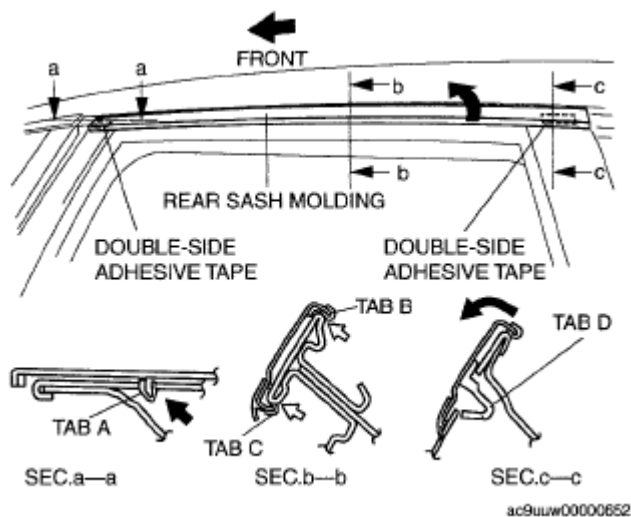

**Fig. 38: Identifying Rear Sash Molding And Double-Sided Adhesive Tape Location**  
 Courtesy of MAZDA MOTORS CORP.

## EXTRACTOR CHAMBER REMOVAL/INSTALLATION

1. Disconnect the negative battery cable.
2. Remove the rear combination light. (See **REAR COMBINATION LIGHT REMOVAL/INSTALLATION** .)
3. Remove the rear bumper. (See **REAR BUMPER REMOVAL/INSTALLATION** .)
4. Remove the rear over fender. (See **OVER FENDER REMOVAL/INSTALLATION**.)
5. Remove the screws.
6. Pull the extractor chamber in the direction shown by the arrow and remove it.
7. Install in the reverse order of removal.

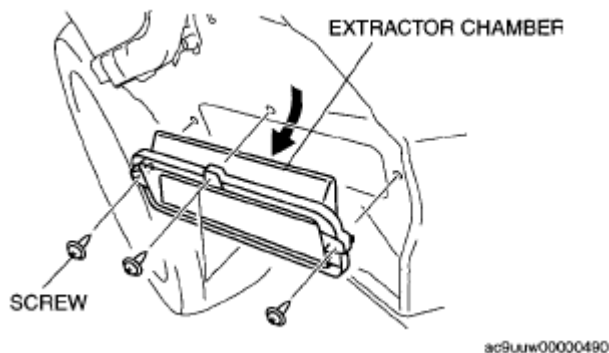

**Fig. 39: Identifying Extractor Chamber Screw**  
Courtesy of MAZDA MOTORS CORP.