

2008 ENGINE

Fuel System (MZI-3.7) - Mazda CX-9

FUEL SYSTEM LOCATION INDEX [MZI-3.7]

ENGINE COMPARTMENT SIDE

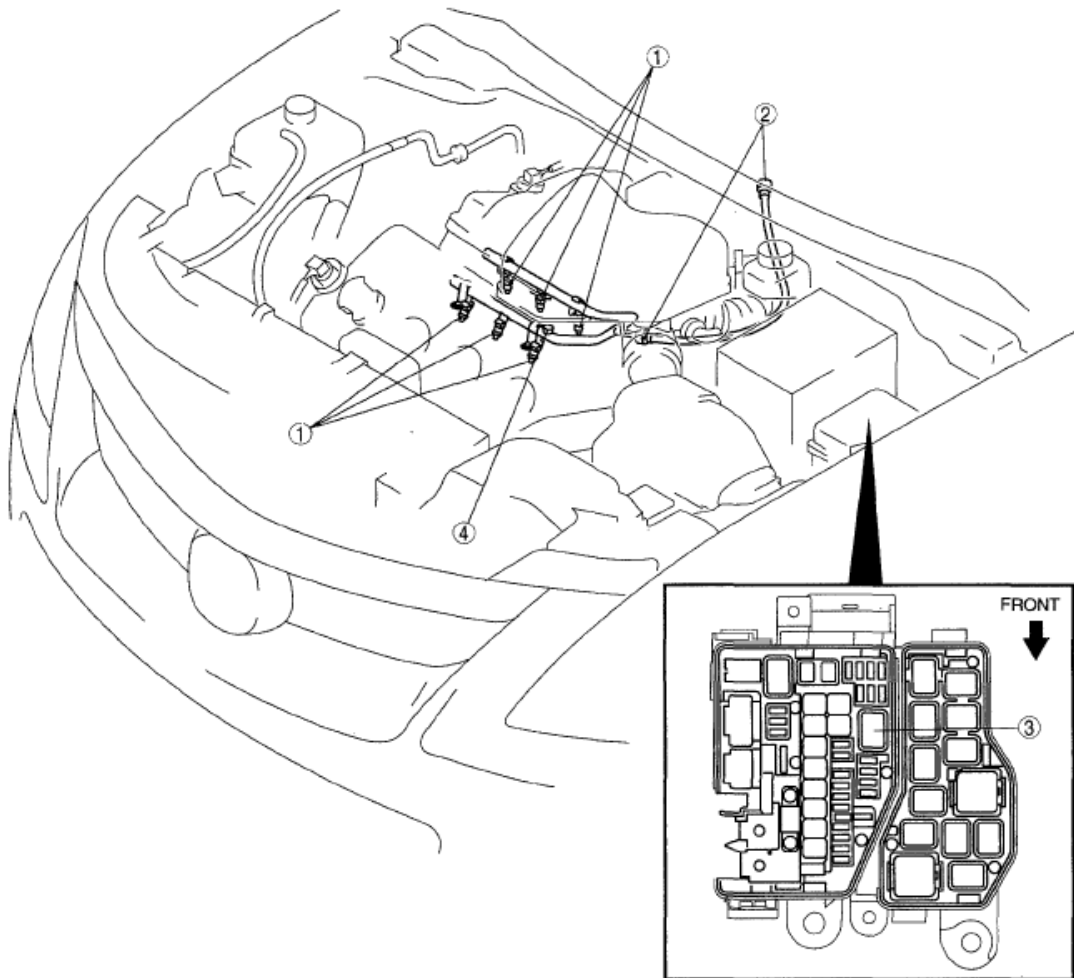

actruuw00000128

1	Fuel injector (See 01-14-23 FUEL INJECTOR REMOVAL/ INSTALLATION [MZI-3.7].) (See 01-14-25 FUEL INJECTOR INSPECTION [MZI-3.7].)
---	--------------------------------------------------------------------------------------------------------------------------------------------

2	Quick release connector (See 01-14-22 QUICK RELEASE CONNECTOR REMOVAL/INSTALLATION [MZI-3.7].)
3	Fuel pump relay (See 09-21-6 RELAY INSPECTION.)
4	Schrader valve

**Fig. 1: Identifying Fuel Injector, Quick Release Connector, Fuel Pump Relay & Schrader Valve**  
Courtesy of MAZDA MOTORS CORP.

FUEL TANK SIDE

**2008 Mazda CX-9 Grand Touring**

2008 ENGINE Fuel System (MZI-3.7) - Mazda CX-9

2WD

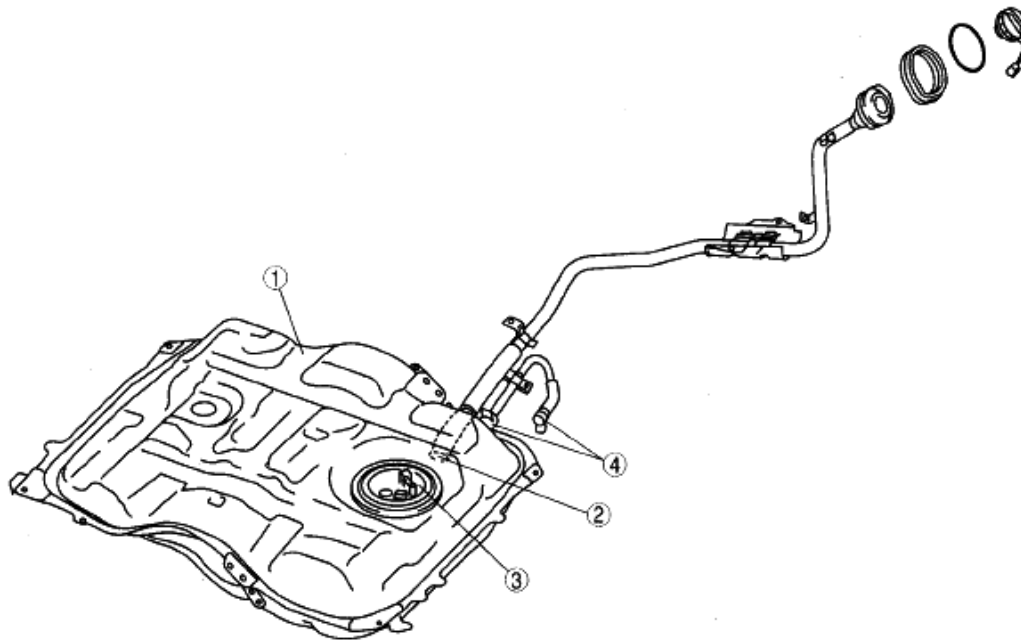

ac9uuw00000673

**Fig. 2: Identifying Fuel Tank, Nonreturn Valve, Fuel Pump Unit & Quick Release Connector (2WD)**  
Courtesy of MAZDA MOTORS CORP.

AWD

## 2008 Mazda CX-9 Grand Touring

2008 ENGINE Fuel System (MZI-3.7) - Mazda CX-9

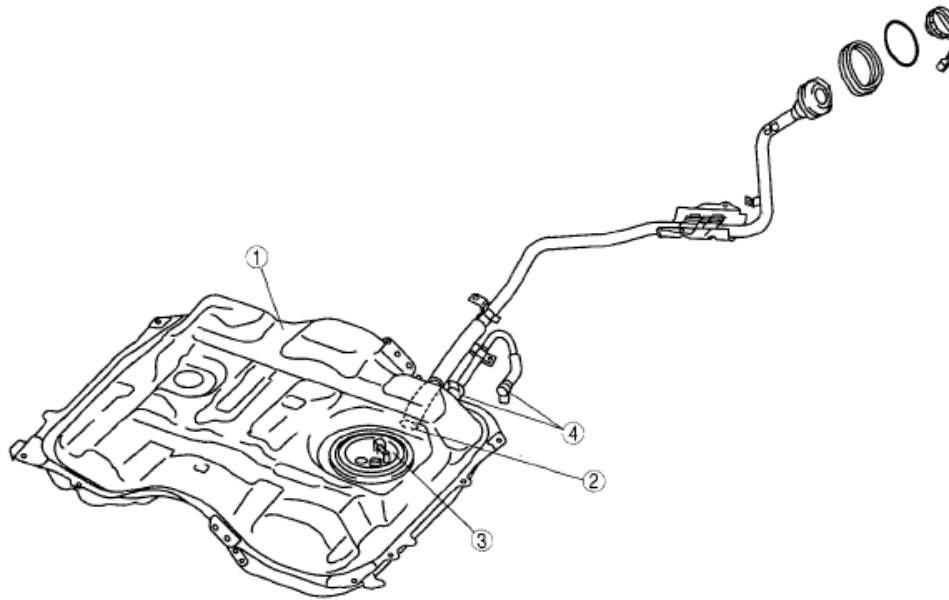

ac9uuw0000176

1	Fuel tank (See 01-14-8 FUEL TANK REMOVAL/ INSTALLATION [MZI-3.7].) (See 01-14-14 FUEL TANK INSPECTION [MZI- 3.7].)
2	Nonreturn valve (See 01-14-15 NONRETURN VALVE INSPECTION [MZI-3.7].)

3	Fuel pump unit (See 01-14-16 FUEL PUMP UNIT REMOVAL/ INSTALLATION [MZI-3.7].) (See 01-14-19 FUEL PUMP UNIT DISASSEMBLY/ ASSEMBLY [MZI-3.7].) (See 01-14-19 FUEL PUMP UNIT INSPECTION [MZI-3.7].)
4	Quick release connector (See 01-14-22 QUICK RELEASE CONNECTOR REMOVAL/INSTALLATION [MZI-3.7].)

**Fig. 3: Identifying Fuel Tank, Nonreturn Valve, Fuel Pump Unit & Quick Release Connector (AWD)**  
Courtesy of MAZDA MOTORS CORP.

## FUEL SYSTEM DIAGRAM [MZI-3.7]

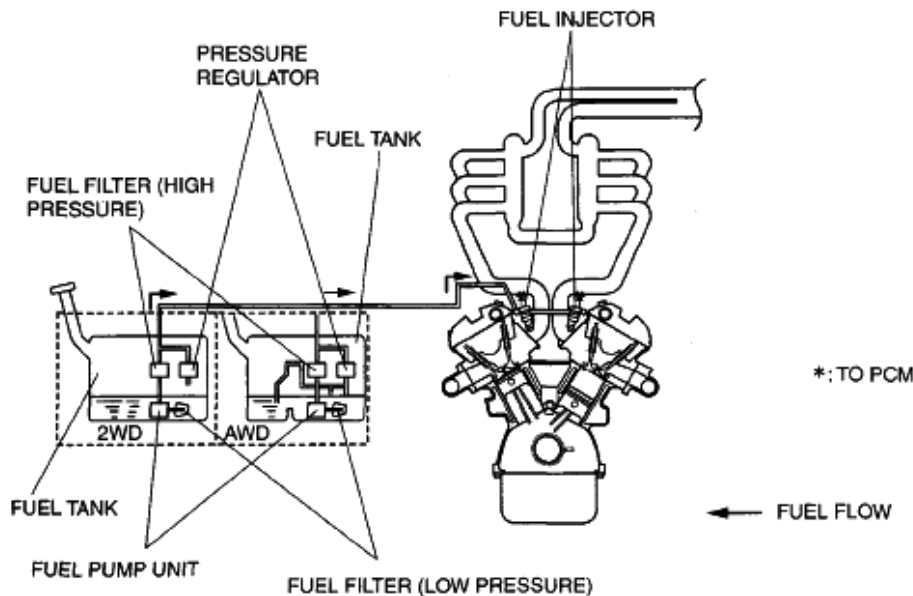

ac9uaw00000180

**Fig. 4: Fuel System Diagram**

Courtesy of MAZDA MOTORS CORP.

## BEFORE SERVICE PRECAUTION [MZI-3.7]

### WARNING:

- Fuel vapor is hazardous. It can easily ignite, causing serious injury and damage. Always keep sparks and flames away from fuel.
- Fuel line spills and leakage are dangerous. Fuel can ignite and cause serious injuries or death and damage. Fuel can also irritate skin and eyes. To prevent this, always complete the following "Fuel Line Safety Procedure".
- A person charged with static electricity could cause a fire or explosion, resulting in death or serious injury. Before performing work on the fuel system, discharge static electricity by touching the vehicle body.

## FUEL LINE SAFETY PROCEDURE

### NOTE:

- Fuel in the fuel system is under high pressure also when the engine is not running.

1. Remove the fuel-filler cap and release the pressure in the fuel tank.
2. Disconnect the negative battery cable. (See [BATTERY REMOVAL/INSTALLATION \[MZI-3.7\]](#) .)
3. Remove the fuel pump relay.
4. Connect the negative battery cable. (See [BATTERY REMOVAL/INSTALLATION \[MZI-3.7\]](#) .)

5. Start the engine.
6. After the engine stalls, crank the engine several times.
7. Turn the ignition switch to LOCK position.
8. Install the fuel pump relay.

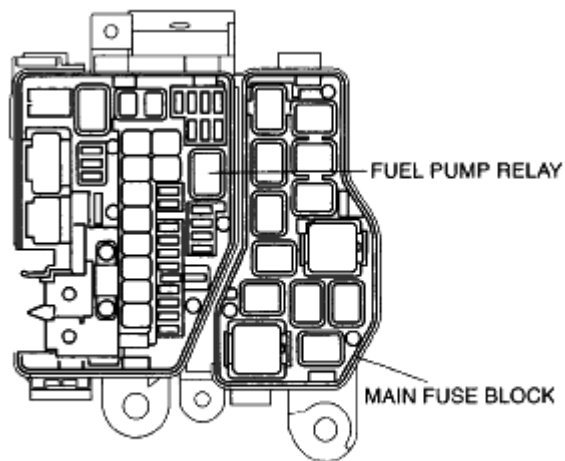

ac9aurw00000129

**Fig. 5: Identifying Fuel Pump Relay & Main Fuse Block**  
Courtesy of MAZDA MOTORS CORP.

## AFTER SERVICE PRECAUTION [MZI-3.7]

### WARNING:

- Fuel line spills and leakage are dangerous. Fuel can ignite and cause serious injuries or death and damage. When installing the fuel hose, observe "Fuel Leakage Inspection" described below.

### FUEL LEAKAGE INSPECTION

### WARNING:

- Fuel line spills and leakage are dangerous. Fuel can ignite and cause serious injuries or death and damage. Always carry out the following procedure with the engine stopped.

### Using M-MDS

1. Connect the M-MDS to the DLC-2.
2. Using the simulation function "FP", start the fuel pump.
3. Verify that there is no fuel leakage from the pressurized parts.
  - If there is leakage, replace the fuel hoses and clips.
  - If there is damage on the seal on the fuel pipe side, replace the fuel pipe.

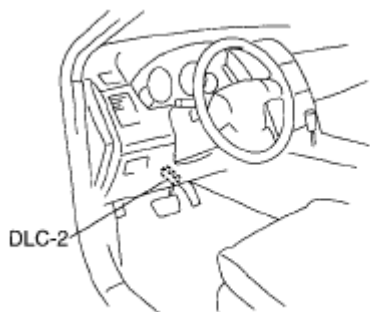

ac9uuw00000119

**Fig. 6: Connecting M-MDS To DLC-2**  
Courtesy of MAZDA MOTORS CORP.

**Standard**

**There shall be no leakage after 5 min.**

4. After reinstallation, repeat step 2 - 3 in the fuel leakage inspection.

**Without using M-MDS**

1. Disconnect the negative battery cable. (See **BATTERY REMOVAL/INSTALLATION [MZI-3.7]** .)
2. Remove the fuel pump relay.

**CAUTION:**

- **Short the specified terminals because shorting the wrong terminal of the main fuse block may cause malfunctions.**

3. Using a jumper wire, short fuel pump relay terminals C and D in the main fuse block.
4. Connect the negative battery cable and operate the fuel pump.
5. Verify that there is no fuel leakage from the pressurized parts.
  - If there is leakage, replace the fuel hoses and clips.
  - If there is damage on the seal on the fuel pipe side, replace the fuel pipe.

MAIN FUSE BLOCK  
(FUEL PUMP RELAY)

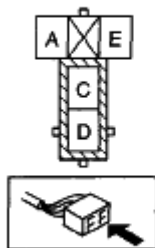

ac9uuw000001018

**Fig. 7: Identifying Main Fuse Block (Fuel Pump Relay)**

Courtesy of MAZDA MOTORS CORP.

Standard

There shall be no leakage after 5 min.

6. After repair, assemble the system and repeat Steps 4 - 5.

## FUEL LINE PRESSURE INSPECTION [MZI-3.7]

**WARNING:**

- Fuel line spills and leakage are dangerous. Fuel can ignite and cause serious injuries or death. Fuel can also irritate skin and eyes. To prevent this, always complete the "BEFORE REPAIR PROCEDURE".

1. Complete the "BEFORE SERVICE PRECAUTION". (See BEFORE SERVICE PRECAUTION [MZI-3.7].)
2. Disconnect the negative battery cable. (See BATTERY REMOVAL/INSTALLATION [MZI-3.7] .)
3. Remove the fuel line schrader valve cap.

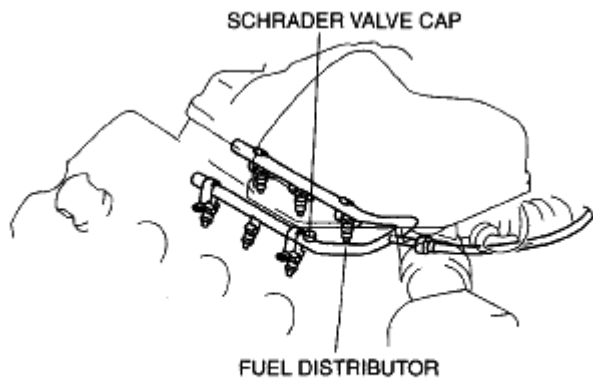

ac9uuw00002152

**Fig. 8: Identifying Schrader Valve Cap & Fuel Distributor**  
Courtesy of MAZDA MOTORS CORP.

4. Turn the SST lever so that it is 90° to the hose as shown in the figure.
5. Make sure the lever of fuel pressure gauge is turned fully clockwise, then connect the SST to the schrader valve.
6. Verify that the selector is in N position.
7. Start the fuel pump using the following procedure.

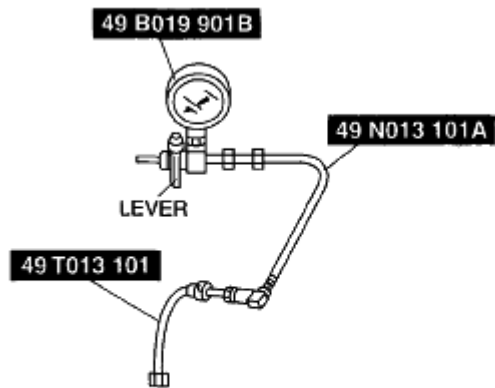

ac9uuw00002400

**Fig. 9: Identifying SST Lever**  
Courtesy of MAZDA MOTORS CORP.

### Using M-MDS

1. Connect the negative battery cable. (See **BATTERY REMOVAL/INSTALLATION [MZI-3.7]** .)
2. Connect the M-MDS to the DLC-2.
3. Using the simulation function "FP", start the fuel pump.

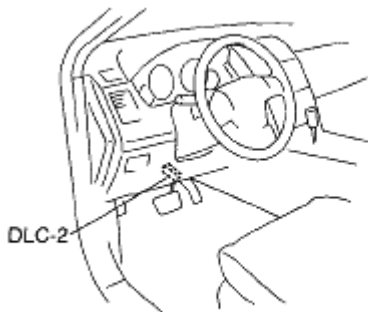

ac9uuw00000115

**Fig. 10: Connecting M-MDS To DLC-2**  
Courtesy of MAZDA MOTORS CORP.

### Without using M-MDS

1. Remove the fuel pump relay.

**CAUTION:** • Short the specified terminals because shorting the wrong terminal of the main fuse block may cause malfunctions.

2. Using a jumper wire, short fuel pump relay terminals C and D in the main fuse block.
3. Connect the negative battery cable and operate the fuel pump.



8. Measure the fuel line pressure, (during key on engine off (KOEO))
- If not as specified, inspect the following:

**Zero or low**

- FP circuit
- FP
- Fuel line (clogging)
- Fuel leakage inside pressure regulator

**High**

- Pressure regulator

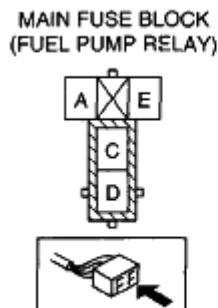

ac914Jw00001018

**Fig. 11: Identifying Main Fuse Block (Fuel Pump Relay)**  
Courtesy of MAZDA MOTORS CORP.

**Fuel line pressure**

**331-485 kPa {3.38-4.94 kgf/cm<sup>2</sup> , 48.1-70.3 psi}**

9. Stop the fuel pump using the following procedure.

**Using M-MDS**

1. Stop the fuel pump using the "FP" simulation function.

**Using M-MDS**

1. Turn the ignition switch off.
  2. Disconnect the negative battery cable to stop the fuel pump.
10. Disconnect the fuel pressure gauge and connect the fuel pipe.
11. Complete the "AFTER SERVICE PRECAUTION". (See **AFTER SERVICE PRECAUTION [MZI-3.7].**)

## FUEL TANK REMOVAL/INSTALLATION [MZI-3.7]

### WARNING:

- Repairing a fuel tank that has not been properly steam cleaned can be dangerous. Explosion or fire may cause death or serious injury. Always properly steam clean a fuel tank before repairing it.
- Fuel line spills and leakage are dangerous. Fuel can ignite and cause serious injuries or death and damage. Fuel can also irritate skin and eyes. To prevent this, do not damage the sealing surface of the fuel pump unit when removing or installing.
- A person charged with static electricity could cause a fire or explosion, resulting in death or serious injury. Before draining fuel, make sure to discharge static electricity by touching the vehicle body.

### CAUTION:

- Disconnecting/connecting the quick release connector without cleaning it may possibly cause damage to the fuel pipe and quick release connector. Always clean the quick release connector joint area before disconnecting/connecting using a cloth or soft brush, and make sure that it is free of foreign material.

### 2WD

1. Level the vehicle.
2. Complete the "BEFORE SERVICE PRECAUTION". (See **BEFORE SERVICE PRECAUTION [MZI-3.7]**.)
3. Disconnect the negative battery cable. (See **BATTERY REMOVAL/INSTALLATION [MZI-3.7]** .)
4. Remove the engine cover. (See **ENGINE COVER REMOVAL/INSTALLATION [MZI-3.7]** .)
5. Remove the fuel line schrader valve cap.
6. Connect a long hose to the disconnected schrader valve cap and drain the fuel into a container used for collecting gasoline.
7. Start the fuel pump using the following procedure.

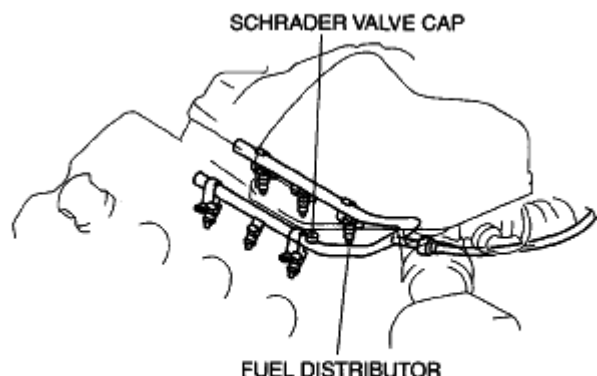

ac9uuw00002153

**Fig. 12: Identifying Schrader Valve Cap & Fuel Distributor**  
Courtesy of MAZDA MOTORS CORP.

### Using M-MDS

1. Connect the negative battery cable. (See **BATTERY REMOVAL/INSTALLATION [MZI-3.7]** .)
2. Connect the M-MDS to the DLC-2.
3. Using the simulation function FP, start the fuel pump.

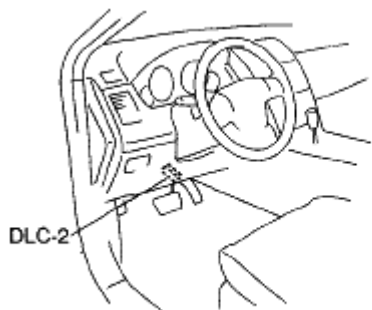

ac9uuw0000114

**Fig. 13: Connecting M-MDS To DLC-2**  
Courtesy of MAZDA MOTORS CORP.

### Without using M-MDS

1. Remove the fuel pump relay.

**CAUTION:** • Short the specified terminals because shorting the wrong terminal of the main fuse block may cause malfunctions.

2. Using a jumper wire, short fuel pump relay terminals C and D in the main fuse block.
3. Connect the negative battery cable and operate the fuel pump.

- CAUTION:**
- The fuel pump could be damaged if it is operated (fuel pump idling) while there is no fuel in the fuel tank. Verify the amount of fuel being discharged from the hose and stop operation of the fuel pump when essentially no fuel is being discharged.

MAIN FUSE BLOCK  
(FUEL PUMP RELAY)

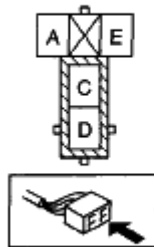

ac9uuw00001018

**Fig. 14: Identifying Main Fuse Block (Fuel Pump Relay)**  
Courtesy of MAZDA MOTORS CORP.

8. When essentially no fuel is being discharged, stop the fuel pump.
9. Disconnect the negative battery cable. (See **BATTERY REMOVAL/INSTALLATION [MZI-3.7]** .)
10. Remove the presilencer. (See **EXHAUST SYSTEM REMOVAL/INSTALLATION [MZI-3.7]** .)
11. To remove the fuel pump unit, remove the following parts:
  1. Second-row seat (LH) (See **SECOND-ROW SEAT REMOVAL/INSTALLATION** .)
  2. Edge cover (See **LONG SLIDER REMOVAL/INSTALLATION** .)
  3. Long slider cover (See **LONG SLIDER REMOVAL/INSTALLATION** .)
  4. Rear heat duct No.3 (See **REAR HEAT DUCT COMPONENT REMOVAL/INSTALLATION** .)
  5. Fuel pump unit (See **FUEL PUMP UNIT REMOVAL/INSTALLATION [MZI-3.7]** .)
12. Siphon the fuel from the fuel tank.
13. Remove in the order indicated in the table.
14. Install in the reverse order of removal.
15. Complete the "AFTER SERVICE PRECAUTION". (See **AFTER SERVICE PRECAUTION [MZI-3.7]** .)

## 2008 Mazda CX-9 Grand Touring

2008 ENGINE Fuel System (MZI-3.7) - Mazda CX-9

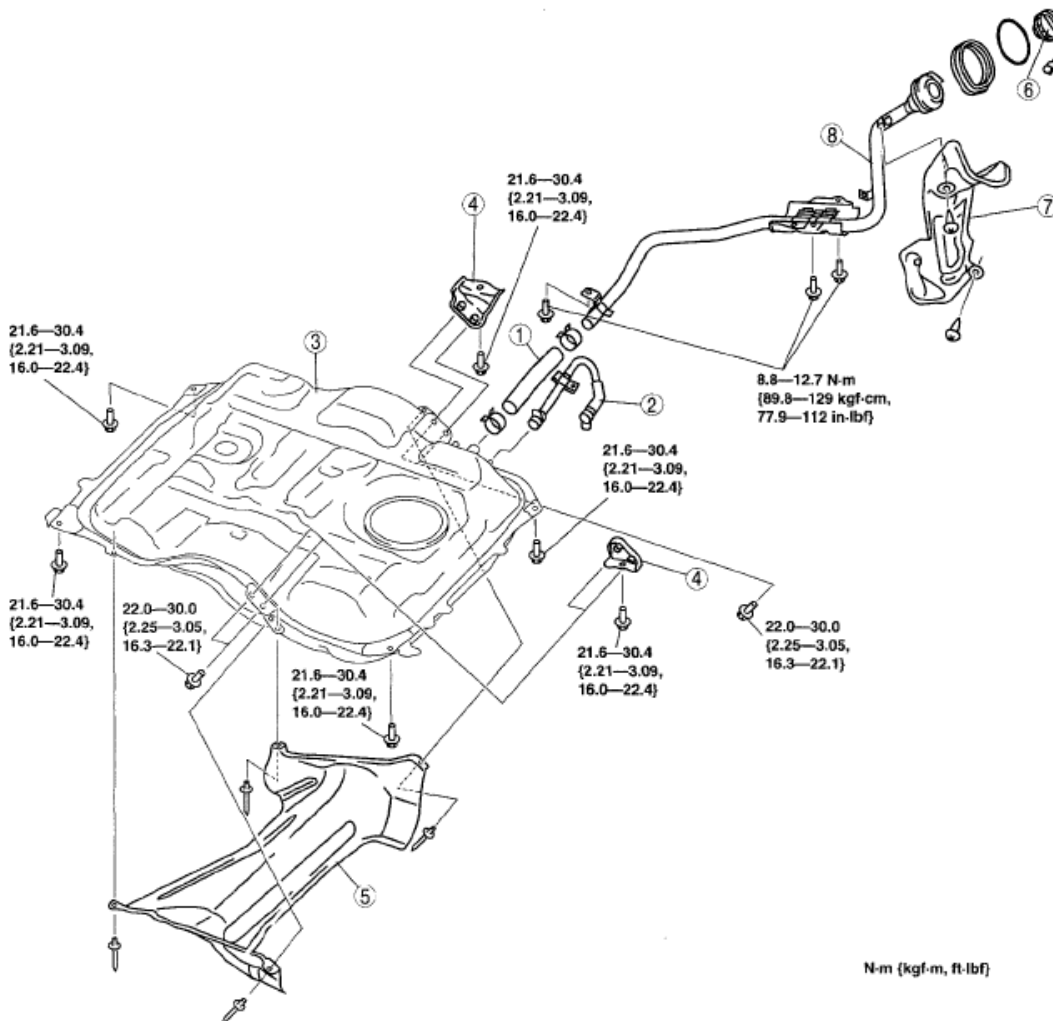

ac9uuw0000184

1	Joint hose
2	Evaporative hose component
3	Fuel tank
4	Fuel tank bracket
5	Fuel tank insulator

6	Fuel-filler cap
7	Fuel-filler pipe protector (See 01-14-10 Fuel-filler pipe protector removal note.)
8	Fuel-filler pipe (See 01-14-10 Fuel-filler pipe removal note.)

**Fig. 15: Identifying Evaporative Hose Component, Fuel Tank, Fuel Tank Bracket, Fuel-Filler Pipe & Torque Specifications**

Courtesy of MAZDA MOTORS CORP.

### Fuel-filler pipe protector removal note

1. Remove the rear tire (LH).
2. Remove the splash shield (LH).
3. Remove the fuel-filler pipe protector.

### Fuel-filler pipe removal note

1. Remove the rear tire (RH).
2. Remove the spare tire.
3. Remove the main silencer (LH). (See **EXHAUST SYSTEM REMOVAL/INSTALLATION [MZI-3.7]** .)
4. Remove the main silencer insulator (LH).
5. To lower the rear crossmember, perform the following procedure:
  1. Set the rear ABS wheel-speed sensor out of the way. (See **REAR ABS WHEEL-SPEED SENSOR REMOVAL/INSTALLATION [2WD]** .)
  2. Rear coil spring (See **REAR COIL SPRING REMOVAL/INSTALLATION** .)
  3. Lowered the rear crossmember. (See **REAR CROSSMEMBER REMOVAL/INSTALLATION [2WD]** .)
6. Remove the fuel-filler pipe.

#### AWD

1. Level the vehicle.
2. Complete the "BEFORE SERVICE PRECAUTION". (See **BEFORE SERVICE PRECAUTION [MZI-3.7]**.)
3. Disconnect the negative battery cable. (See **BATTERY REMOVAL/INSTALLATION [MZI-3.7]** .)
4. Remove the engine cover. (See **ENGINE COVER REMOVAL/INSTALLATION [MZI-3.7]** .)
5. Remove the fuel line schrader valve cap.
6. Connect a long hose to the disconnected schrader valve cap and drain the fuel into a container used for collecting gasoline.
7. Start the fuel pump using the following procedure.

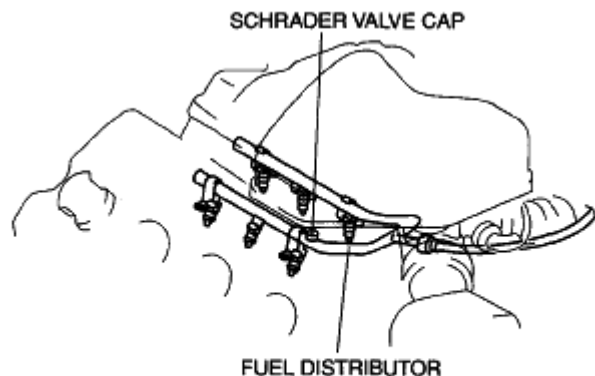

ac9uuw00002153

**Fig. 16: Identifying Schrader Valve Cap & Fuel Distributor**  
Courtesy of MAZDA MOTORS CORP.

1. Connect the negative battery cable. (See **BATTERY REMOVAL/INSTALLATION [MZI-3.7]** .)
2. Connect the M-MDS to the DLC-2.
3. Using the simulation function FP, start the fuel pump.

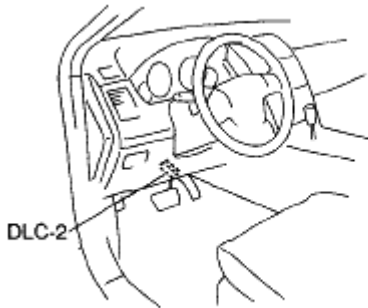

ac9uuw00000114

**Fig. 17: Connecting M-MDS To DLC-2**  
 Courtesy of MAZDA MOTORS CORP.

**Without using M-MDS**

1. Remove the fuel pump relay.

**CAUTION:** • Short the specified terminals because shorting the wrong terminal of the main fuse block may cause malfunctions.

2. Using a jumper wire, short fuel pump relay terminals C and D in the main fuse block.
3. Connect the negative battery cable and operate the fuel pump.

**CAUTION:** • The fuel pump could be damaged if it is operated (fuel pump idling) while there is no fuel in the fuel tank. Verify the amount of fuel being discharged from the hose and stop operation of the fuel pump when essentially no fuel is being discharged.

MAIN FUSE BLOCK  
 (FUEL PUMP RELAY)

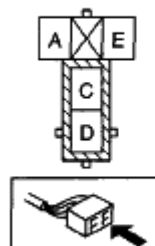

ac9uuw00001018

**Fig. 18: Identifying Main Fuse Block (Fuel Pump Relay)**

Courtesy of MAZDA MOTORS CORP.

8. When essentially no fuel is being discharged, stop the fuel pump.
9. Disconnect the negative battery cable. (See **BATTERY REMOVAL/INSTALLATION [MZI-3.7]** .)
10. To remove the propeller shaft, remove the following parts:
  1. Presilencer (See **EXHAUST SYSTEM REMOVAL/INSTALLATION [MZI-3.7]** .)
  2. Presilencer insulator
  3. Propeller shaft (See **PROPELLER SHAFT REMOVAL/INSTALLATION** .)
11. To remove the fuel pump unit, remove the following parts:
  1. Second-row seat (LH) (See **SECOND-ROW SEAT REMOVAL/INSTALLATION** .)
  2. Edge cover (See **LONG SLIDER REMOVAL/INSTALLATION** .)
  3. Long slider cover (See **LONG SLIDER REMOVAL/INSTALLATION** .)

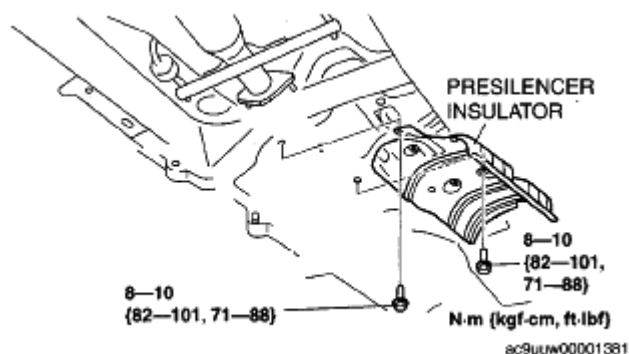

**Fig. 19: Identifying Presilencer Insulator & Torque Specifications**  
 Courtesy of MAZDA MOTORS CORP.

4. Rear heat duct No.3 (See **REAR HEAT DUCT COMPONENT REMOVAL/INSTALLATION** .)
5. Fuel pump unit (See **FUEL PUMP UNIT REMOVAL/INSTALLATION [MZI-3.7]**.)
12. Siphon the fuel from the fuel tank.
13. Remove in the order indicated in the table.
14. Install in the reverse order of removal.
15. Complete the "AFTER SERVICE PRECAUTION". (See **AFTER SERVICE PRECAUTION [MZI-3.7]**.)



## 2008 Mazda CX-9 Grand Touring

2008 ENGINE Fuel System (MZI-3.7) - Mazda CX-9

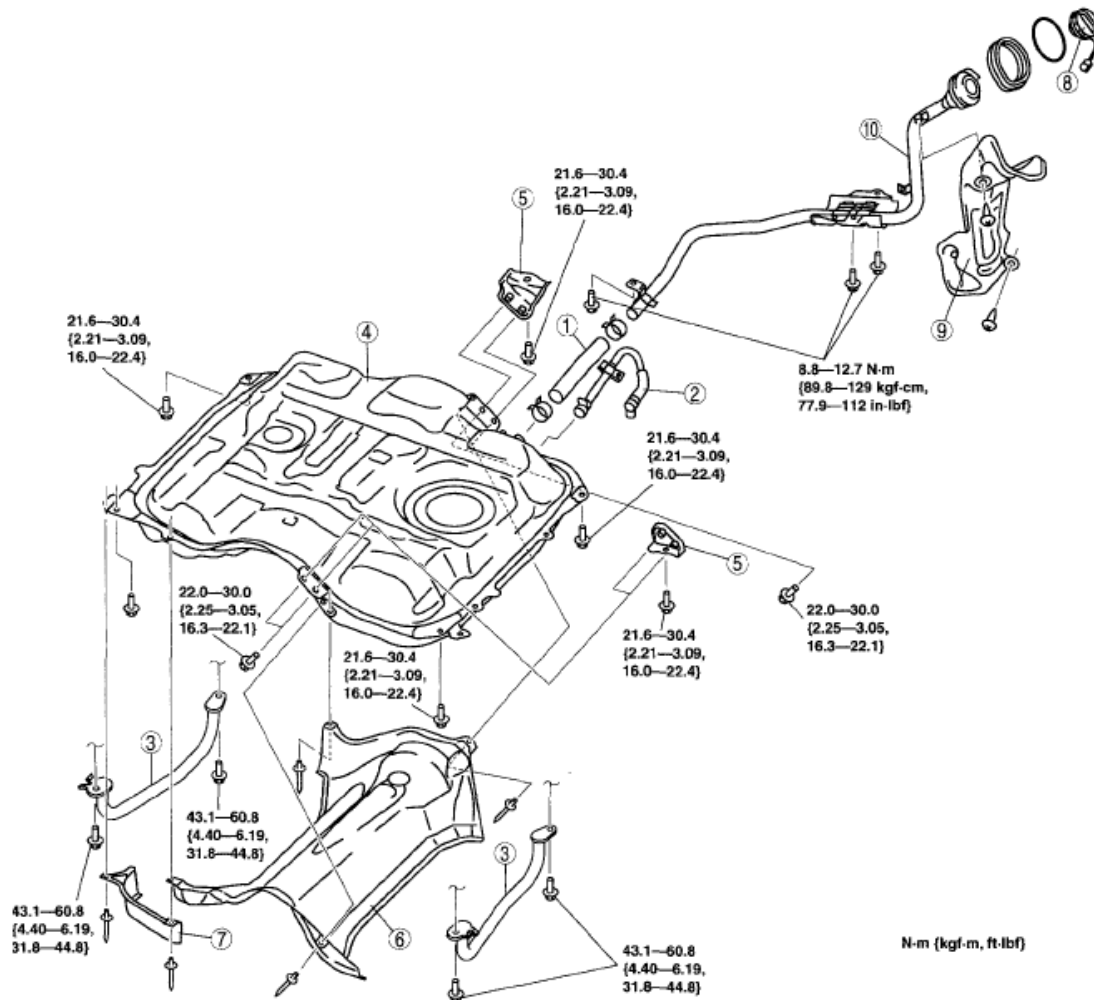

ac9uuw00002427

1	Joint hose
2	Evaporative hose
3	Protector
4	Fuel tank
5	Fuel tank bracket
6	Fuel tank insulator No.1

7	Fuel tank insulator No.2
8	Fuel-filler cap
9	Fuel-filler pipe protector (See 01-14-13 Fuel-filler pipe protector removal note.)
10	Fuel-filler pipe (See 01-14-13 Fuel-filler pipe removal note.)

**Fig. 20: Identifying Evaporative Hose Component, Fuel Tank, Fuel Tank Bracket, Fuel-Filler Pipe & Torque Specifications**  
 Courtesy of MAZDA MOTORS CORP.

### Fuel-filler pipe protector removal note

1. Remove the rear tire (LH).
2. Remove the splash shield (LH).
3. Remove the fuel-filler pipe protector.

### Fuel-filler pipe removal note

1. Remove the rear tire (RH).
2. Remove the spare tire.
3. Remove the main silencer (LH). (See **EXHAUST SYSTEM REMOVAL/INSTALLATION [MZI-3.7]** .)
4. Remove the main silencer insulator (LH).
5. To lower the rear crossmember, perform the following procedure:
  1. Set the rear ABS wheel-speed sensor out of the way. (See **REAR ABS WHEEL-SPEED SENSOR REMOVAL/INSTALLATION [AWD]** .)
  2. Rear coil spring (See **REAR COIL SPRING REMOVAL/INSTALLATION** .)
  3. Lowered the rear crossmember. (See **REAR CROSSMEMBER REMOVAL/INSTALLATION [AWD]** .)
6. Remove the fuel-filler pipe.

## **FUEL TANK INSPECTION [MZI-3.7]**

**NOTE:**                   • **This inspection is for three rollover valves and fuel shut-off valve integrated in the fuel tank.**

1. Follow "BEFORE SERVICE PRECAUTION" before performing any work operations to prevent fuel from spilling from the fuel system. (See **BEFORE SERVICE PRECAUTION [MZI-3.7]**.)
2. Disconnect the negative battery cable. (See **BATTERY REMOVAL/INSTALLATION [MZI-3.7]** .)
3. To disconnect the fuel pump unit connector, remove the following parts:
  1. Second-row seat (LH) (See **SECOND-ROW SEAT REMOVAL/INSTALLATION** .)
  2. Edge cover (See **LONG SLIDER REMOVAL/INSTALLATION** .)
  3. Long slider cover (See **LONG SLIDER REMOVAL/INSTALLATION** .)
  4. Rear heat duct No.3 (See **REAR HEAT DUCT COMPONENT REMOVAL/INSTALLATION** .)
  5. Disconnect the fuel pump unit connector.
4. Disconnect the quick release connector and the fuel pump unit connector. (See **QUICK RELEASE CONNECTOR REMOVAL/INSTALLATION [MZI-3.7]**.)
5. Disconnect the joint hose. (See **FUEL TANK INSPECTION [MZI-3.7]**.)
6. Disconnect the evaporative hose. (See **FUEL TANK REMOVAL/INSTALLATION [MZI-3.7]**.)
7. Remove the fuel tank with the fuel pump unit. (See **FUEL TANK REMOVAL/INSTALLATION [MZI-3.7]**.)
8. Perform the following procedure to verify the fuel tank air-tightness.
  1. Plug the fuel pump unit pipe and port B.

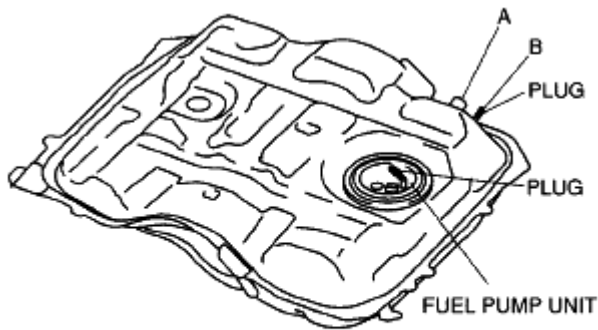

ac9uuw00000131

**Fig. 21: Identifying Fuel Pump Unit & Plug (2WD)**  
Courtesy of MAZDA MOTORS CORP.

**AWD**

2. Apply a pressure of **3 kPa {23 mmHg, 0.9 inHg}** to port A and wait for a while.
3. Verify that there is no air leakage from the fuel tank.
  - If there is airflow, replace the fuel tank.
9. Level the fuel tank.
10. Apply a pressure of **3 kPa {23 mmHg, 0.9 inHg}** to port B and wait for a while.
11. With the pressure still applied, verify that there is airflow from port A and the pressure is **0-3 kPa {0-22 mmHg, 0-0.8 inHg}**.
  - If malfunction, replace the fuel tank.
12. Apply a pressure of **-0.5 kPa {-3.8 mmHg, -0.1 inHg}** to port B and wait for a while.

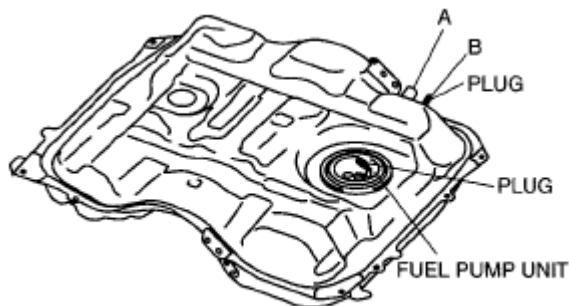

ac9uuw00000177

**Fig. 22: Identifying Fuel Pump Unit & Plug (4WD)**  
Courtesy of MAZDA MOTORS CORP.

13. With the pressure still applied, verify that there is airflow from port A and the pressure is **-0.5-0 kPa {-3.8-0 mmHg, -0.2-0 inHg}**.
  - If malfunction, replace the fuel tank.

- If there is airflow, place the fuel tank upside down.
14. Apply a pressure of **3 kPa {23 mmHg, 0.9 inHg}** to port B and wait for a while.

**2WD**

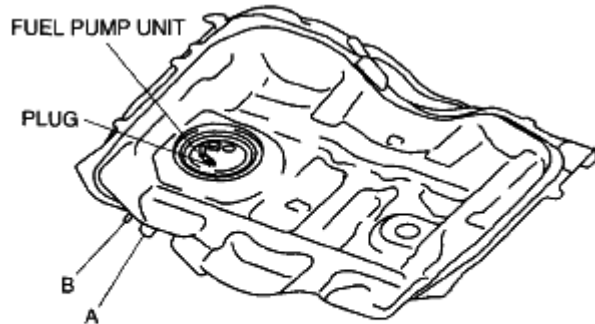

ac9uuw0000132

**Fig. 23: Identifying Fuel Pump Unit & Plug (2WD)**  
Courtesy of MAZDA MOTORS CORP.

**AWD**

15. With the pressure still applied, verify that there is no airflow from port A.
- If there is airflow, replace the fuel tank.
16. Complete the "AFTER SERVICE PRECAUTION". (See **AFTER SERVICE PRECAUTION [MZI-3.7]**.)

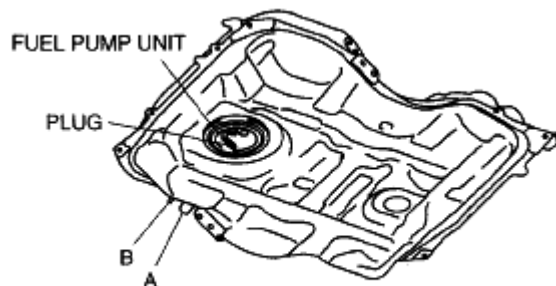

ac9uuw00002430

**Fig. 24: Identifying Fuel Pump Unit & Plug (4WD)**  
Courtesy of MAZDA MOTORS CORP.

**NONRETURN VALVE INSPECTION [MZI-3.7]**

**WARNING:**

- Fuel is very flammable liquid. If fuel spills or leaks from the pressurized fuel system, it will cause serious injury or death and

facility breakage. Fuel can also irritate skin and eyes. To prevent this, always complete the "Fuel Line Safety Procedure", while referring to the "BEFORE SERVICE PRECAUTION".

1. Follow "BEFORE SERVICE PRECAUTION" before performing any work operations to prevent fuel from spilling from the fuel system. (See BEFORE SERVICE PRECAUTION [MZI-3.7].)
2. Disconnect the negative battery cable.
3. Remove the fuel pump unit. (See FUEL PUMP UNIT REMOVAL/INSTALLATION [MZI-3.7].)
4. Siphon the fuel from the fuel tank.

**NOTE:**

- Nonreturn valve is integrated in the fuel tank.
  - The nonreturn valve is normally closed by the spring force.
  - Verify the nonreturn valve operation using a mirror.
5. Verify that the nonreturn valve is closed.
    - If malfunction, replace the fuel tank. (See FUEL TANK REMOVAL/INSTALLATION [MZI-3.7].)
  6. Verify that the nonreturn valve is not stuck open and does not open even when pulled up by a finger.
    - If malfunction, replace the fuel tank. (See FUEL TANK REMOVAL/INSTALLATION [MZI-3.7].)

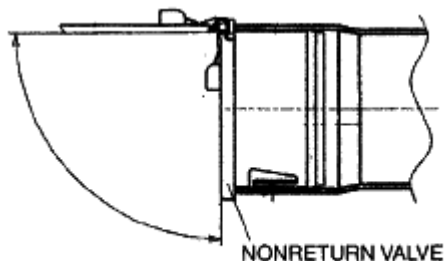

ac8urw0002456

**Fig. 25: Identifying Nonreturn Valve**  
Courtesy of MAZDA MOTORS CORP.

## FUEL PUMP UNIT REMOVAL/INSTALLATION [MZI-3.7]

**WARNING:**

- Fuel line spills and leakage are dangerous. Fuel can ignite and cause serious injuries or death and damage. Fuel can also irritate skin and eyes. To prevent this, always complete the "Fuel Line Safety Procedure".
- Fuel line spills and leakage are dangerous. Fuel can ignite and cause serious injuries or death and damage. Fuel can also irritate skin and eyes. To prevent this, before performing the fuel pump unit

removal/installation, always complete the "Fuel Leak Inspection After Fuel Pump Unit Installation".

- A person charged with static electricity could cause a fire or explosion, resulting in death or serious injury. Before draining fuel, make sure to discharge static electricity by touching the vehicle body.

**CAUTION:**

- Because the fuel tank is constructed such that the fuel level is higher than the installation surface of the fuel pump, fuel leakage could occur. If the fuel gauge indicates a fuel level of 3/4 or more, perform the following Steps 3 - 8 to drain 10-15 L {2.7-3.9 US gal, 2.2-3.2 Imp gal} of fuel.
- Disconnecting/connecting the quick release connector without cleaning it may possibly cause damage to the fuel pipe and quick release connector. Always clean the quick release connector joint area before disconnecting/connecting using a cloth or soft brush, and make sure that it is free of foreign material.

1. Level the vehicle.
2. Complete the "BEFORE SERVICE PRECAUTION". (See **BEFORE SERVICE PRECAUTION [MZI-3.7]**.)
3. Disconnect the negative battery cable. (See **BATTERY REMOVAL/INSTALLATION [MZI-3.7]** .)
4. Remove the engine cover. (See **ENGINE COVER REMOVAL/INSTALLATION [MZI-3.7]** .)
5. Remove the fuel line schrader valve cap.
6. Connect a long hose to the disconnected schrader valve cap and drain the fuel into a container used for collecting gasoline.
7. Start the fuel pump using the following procedure.

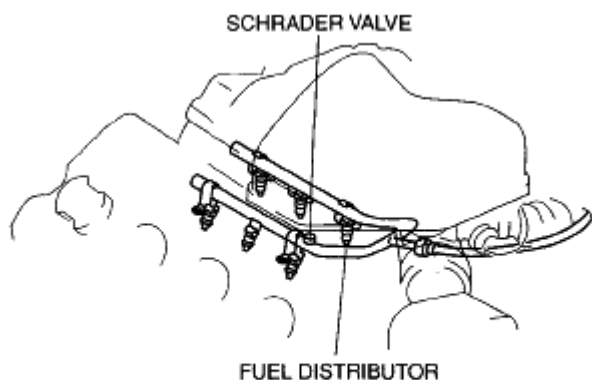

ac9uuw00000425

**Fig. 26: Identifying Schrader Valve Cap & Fuel Distributor**  
 Courtesy of MAZDA MOTORS CORP.

### Using M-MDS

1. Connect the negative battery cable. (See **BATTERY REMOVAL/INSTALLATION [MZI-3.7]** .)
2. Connect the M-MDS to the DLC-2.
3. Using the simulation function "FP", start the fuel pump.

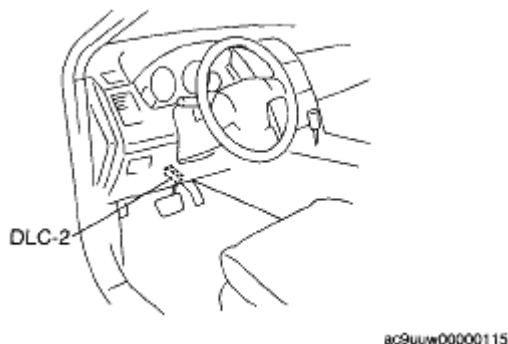

**Fig. 27: Connecting M-MDS To DLC-2**  
Courtesy of MAZDA MOTORS CORP.

### Without using M-MDS

1. Remove the fuel pump relay.

**CAUTION:**

- Short the specified terminals because shorting the wrong terminal of the main fuse block may cause malfunctions.

2. Using a jumper wire, short fuel pump relay terminals C and D in the main fuse block.
3. Connect the negative battery cable and operate the fuel pump.

**CAUTION:**

- The fuel pump could be damaged if it is operated (fuel pump idling) while there is no fuel in the fuel tank. Verify the amount of fuel being discharged from the hose and stop operation of the fuel pump when essentially no fuel is being discharged.

## 2008 Mazda CX-9 Grand Touring

2008 ENGINE Fuel System (MZI-3.7) - Mazda CX-9

MAIN FUSE BLOCK  
(FUEL PUMP RELAY)

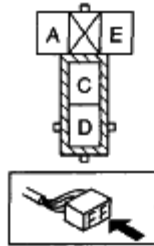

ac9uuw00001018

**Fig. 28: Identifying Main Fuse Block (Fuel Pump Relay)**  
Courtesy of MAZDA MOTORS CORP.

8. When essentially no fuel is being discharged, stop operation of the fuel pump.
9. Disconnect the negative battery cable. (See **BATTERY REMOVAL/INSTALLATION [MZI-3.7]** .)
10. To remove the rear heat duct No.3, remove the following parts:
  1. Second-row seat (LH) (See **SECOND-ROW SEAT REMOVAL/INSTALLATION** .)
  2. Edge cover (See **LONG SLIDER REMOVAL/INSTALLATION** .)
  3. Long slider cover (See **LONG SLIDER REMOVAL/INSTALLATION** .)
  4. Remove the rear heat duct No.3. (See **REAR HEAT DUCT COMPONENT REMOVAL/INSTALLATION** .)
11. Remove in the order indicated in the table.
12. Install in the reverse order of removal.
13. Complete the "AFTER SERVICE PRECAUTION". (See **AFTER SERVICE PRECAUTION [MZI-3.7]**.)

### 2WD

1	Service hole cover
2	Connector
3	Quick release connector (See 01-14-22 QUICK RELEASE CONNECTOR REMOVAL/INSTALLATION [MZI-3.7].)
4	Fuel pump unit
5	Packing

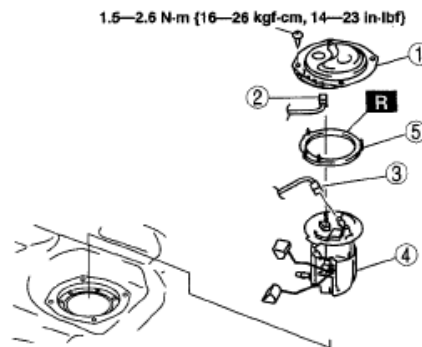

ac9uuw00002431

**Fig. 29: Identifying Fuel Pump Unit, Quick Release Connector, Service Hole Cover & Torque Specifications (2WD)**  
Courtesy of MAZDA MOTORS CORP.



## 2008 Mazda CX-9 Grand Touring

2008 ENGINE Fuel System (MZI-3.7) - Mazda CX-9

### AWD

1	Service hole cover
2	Connector
3	Quick release connector (See 01-14-22 QUICK RELEASE CONNECTOR REMOVAL/INSTALLATION [MZI-3.7].)
4	Quick release connector (See 01-14-22 QUICK RELEASE CONNECTOR REMOVAL/INSTALLATION [MZI-3.7].)
5	Fuel pump unit
6	Packing

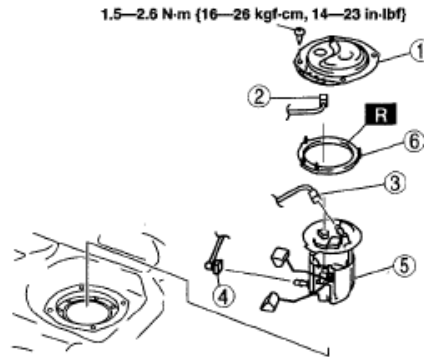

ac9uuw00001187

**Fig. 30: Identifying Fuel Pump Unit, Quick Release Connector, Service Hole Cover & Torque Specifications (AWD)**

Courtesy of MAZDA MOTORS CORP.

### FUEL PUMP UNIT DISASSEMBLY/ASSEMBLY [MZI-3.7]

1. Disassemble in the order indicated in the table.
2. Assemble in the reverse order of disassembly.

1	Fuel filter body
2	Pressure regulator
3	O-ring
4	Fuel pump
5	O-ring
6	Spacer
7	Fuel filter (low-pressure)
8	Sender gauge

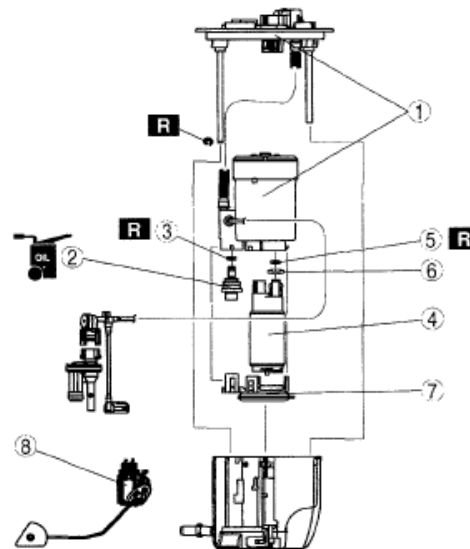

ac9uuw00000273

**Fig. 31: Identifying Fuel Filter Body, Pressure Regulator, O-Ring & Fuel Pump**  
Courtesy of MAZDA MOTORS CORP.

### FUEL PUMP UNIT INSPECTION [MZI-3.7]

**CAUTION:**

- It is normal to hear the fuel pump operating when the ignition switch

is turned to the ON position.

**NOTE:**

- To improve start ability, the fuel pump control operates the fuel pump unit when the ignition switch is turned to the ON position. Due to this, fuel pressure is rapidly increased and fuel control is stabilized.

**OPERATION TEST**

1. Follow "BEFORE SERVICE PRECAUTION" before performing any work operations to prevent fuel from spilling from the fuel system. (See **BEFORE SERVICE PRECAUTION [MZI-3.7].**)
2. Remove the fuel-filler cap. (See **FUEL TANK REMOVAL/INSTALLATION [MZI-3.7].**)
3. Start the fuel pump using the following procedure:

**Using M-MDS**

1. Connect the M-MDS to the DLC-2.
2. Turn the ignition switch to the ON position.

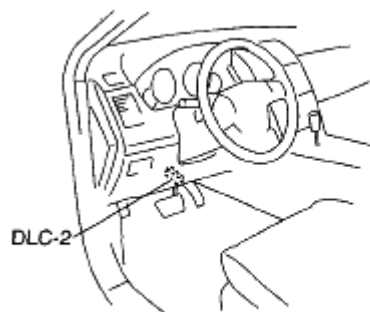

ac9uww00000116

**Fig. 32: Connecting M-MDS To DLC-2**  
Courtesy of MAZDA MOTORS CORP.

3. Using the simulation function FP, verify that operation sound is heard from the fuel pump when FP is turned from OFF to ON.
  - If the operation sound cannot be verified, measure the voltage at fuel pump wiring harness-side connector terminal B.
    - If as specified, inspect the following:
      - Fuel pump continuity
    - If not within the specification, inspect the following:
      - Fuel pump relay
      - Wiring harnesses and connectors between battery-fuel pump relay-fuel pump

FUEL PUMP UNIT  
WIRING HARNESS-SIDE CONNECTOR

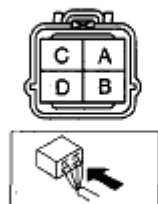

ac9uuw00001003

**Fig. 33: Identifying Fuel Pump Unit Wiring Harness-Side Connector**  
Courtesy of MAZDA MOTORS CORP.

### Standard

B+ (Ignition switch at ON)

Without using M-MDS

1. Disconnect the negative battery cable. (See **BATTERY REMOVAL/INSTALLATION [MZI-3.7]** .)
2. Remove the fuel pump relay.

**CAUTION:** • Short the specified terminals because shorting the wrong terminal of the main fuse block may cause malfunctions.

3. Using a jumper wire, short fuel pump relay terminals C and D in the main fuse block.
4. Connect the negative battery cable and operate the fuel pump.
5. Verify that operation sound is heard from the fuel pump when ignition switch turn to the ON position.

MAIN FUSE BLOCK  
(FUEL PUMP RELAY)

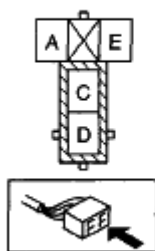

ac9uuw00001018

**Fig. 34: Identifying Main Fuse Block (Fuel Pump Relay)**  
Courtesy of MAZDA MOTORS CORP.

- If the operation sound cannot be verified, measure the voltage at fuel pump wiring harness-

side connector terminal B.

- If as specified, inspect the following:
  - Fuel pump continuity
- If not within the specification, inspect the following:
  - Fuel pump relay
  - Wiring harnesses and connectors between battery-fuel pump relay-fuel pump

## Standard

### B+ (Ignition switch at ON)

FUEL PUMP UNIT  
WIRING HARNESS-SIDE CONNECTOR

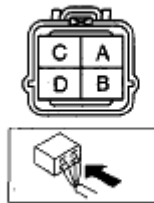

ac9uuw00001003

**Fig. 35: Identifying Fuel Pump Unit Wiring Harness-Side Connector**  
Courtesy of MAZDA MOTORS CORP.

6. Disconnect the jumper wire.
4. Complete the "AFTER SERVICE PRECAUTION". (See **AFTER SERVICE PRECAUTION [MZI-3.7].**)

## CONTINUITY INSPECTION

1. Disconnect the negative battery cable. (See **BATTERY REMOVAL/INSTALLATION [MZI-3.7]** .)
2. To remove the service hole cover, remove the following parts:
  1. Second-row seat (See **SECOND-ROW SEAT REMOVAL/INSTALLATION** .)
  2. Edge cover (See **LONG SLIDER REMOVAL/INSTALLATION** .)
  3. Long slider cover (See **LONG SLIDER REMOVAL/INSTALLATION** .)
  4. Rear heat duct No.3 (See **REAR HEAT DUCT COMPONENT REMOVAL/INSTALLATION** .)
  5. Service hole cover (See **FUEL PUMP UNIT REMOVAL/INSTALLATION [MZI-3.7].**)
3. Disconnect the fuel pump unit connector.
4. Inspect for continuity between fuel pump unit connector terminals B and D.
  - If there is no continuity, replace the fuel pump unit. (See **FUEL PUMP UNIT REMOVAL/INSTALLATION [MZI-3.7].**)
  - If as specified carry out the "Circuit Open/Short Inspection".

FUEL PUMP UNIT  
WIRING HARNESS-SIDE CONNECTOR

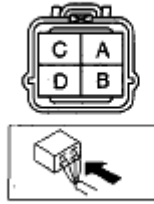

ac9uuw00001003

**Fig. 36: Identifying Fuel Pump Unit Wiring Harness-Side Connector**  
Courtesy of MAZDA MOTORS CORP.

### CIRCUIT OPEN/SHORT INSPECTION

1. Inspect the following wiring harnesses for open or short circuit (continuity check).

MAIN FUSE BLOCK  
(FUEL PUMP RELAY)

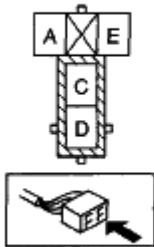

ac9uuw00001018

**Fig. 37: Identifying Main Fuse Block (Fuel Pump Relay)**  
Courtesy of MAZDA MOTORS CORP.

FUEL PUMP UNIT  
WIRING HARNESS-SIDE CONNECTOR

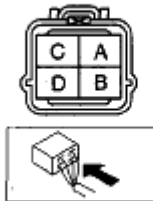

ac9uuw00001003

**Fig. 38: Identifying Fuel Pump Unit Wiring Harness-Side Connector**  
Courtesy of MAZDA MOTORS CORP.

### Open circuit

- If there is no continuity, the circuit is open. Repair or replace the harness.

- Fuel pump unit terminal D and body ground
- Fuel pump unit terminal C and fuel pump relay terminal D

### Short circuit

- If there is continuity, the circuit is short. Repair or replace the harness.
  - Fuel pump unit terminal D and power supply
  - Fuel pump unit terminal B and body ground

## QUICK RELEASE CONNECTOR REMOVAL/INSTALLATION [MZI-3.7]

### WARNING:

- Fuel is very flammable liquid. If fuel spills or leaks from the pressurized fuel system, it will cause serious injury or death and facility breakage. Fuel can also irritate skin and eyes. To prevent this, always complete the "Fuel Line Safety Procedure", while referring to the "BEFORE SERVICE PRECAUTION".

### QUICK RELEASE CONNECTOR POSITION

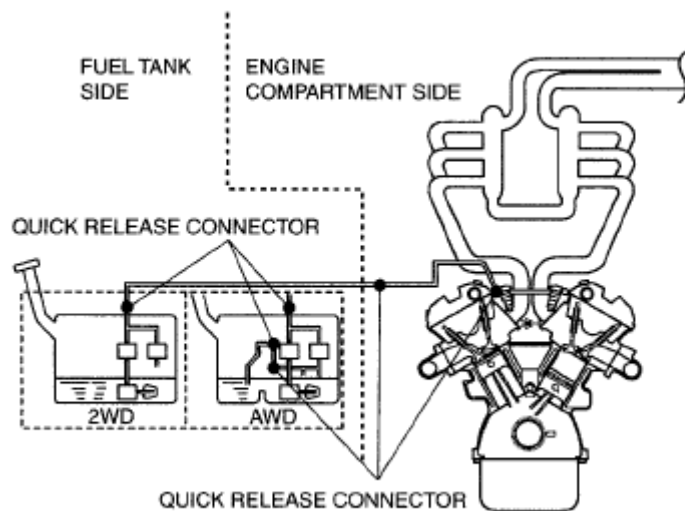

ac9uuw00000181

**Fig. 39: Identifying Quick Release Connector**  
Courtesy of MAZDA MOTORS CORP.

### REMOVAL

1. Follow "BEFORE SERVICE PRECAUTION" and remove dirt from the connecting surfaces before performing any work operations. (See BEFORE SERVICE PRECAUTION [MZI-3.7].)
2. Move the retainer upward using a small flathead screwdriver or a similar tool.
3. Pull out the fuel hose straight from the fuel pipe and disconnect it.

- Cover the disconnected quick release connector and fuel pipe with vinyl sheeting or a similar material to prevent it from scratches or dirt.

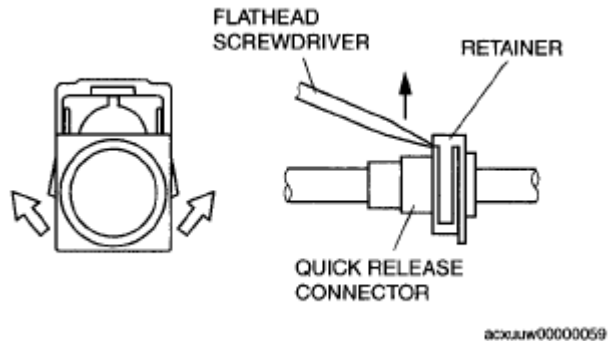

**Fig. 40: View Of Quick Release Connector**  
Courtesy of MAZDA MOTORS CORP.

## INSTALLATION

### NOTE:

- If the quick release connector O-ring is damaged or has slipped, replace the fuel hose.

- Inspect the fuel hose and fuel pipe sealing surface for damage and deformation.
  - If there is any malfunction, replace it with a new one.
- Install the quick release connector.
  - Insert the fuel pipe straight to the end of the quick release connector.
  - Push down the retainer using a finger.
    - If the retainer cannot be pushed down, push the fuel pipe further to the quick release connector.
- Lightly pull and push the quick release connector a few times by hand, and then verify that it is connected securely.
- Inspect all related parts by performing "AFTER SERVICE PRECAUTION". (See **AFTER SERVICE PRECAUTION [MZI-3.7].**)

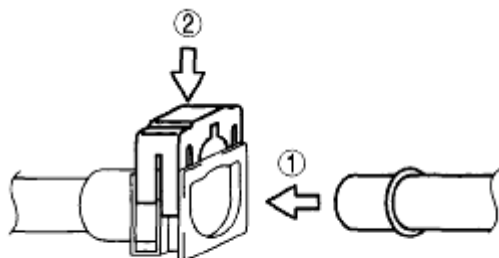

acxuuw00000061

**Fig. 41: View Of Quick Release Connector**

Courtesy of MAZDA MOTORS CORP.

## FUEL INJECTOR REMOVAL/INSTALLATION [MZI-3.7]

**WARNING:**

- Fuel is very flammable liquid. If fuel spills or leaks from the pressurized fuel system, it will cause serious injury or death and facility breakage. Fuel can also irritate skin and eyes. To prevent this, always complete the "Fuel Line Safety Procedure", while referring to the "**BEFORE SERVICE PRECAUTION**".

1. Complete the "BEFORE SERVICE PRECAUTION". (See **BEFORE SERVICE PRECAUTION [MZI-3.7]**.)
2. Disconnect the negative battery cable. (See **BATTERY REMOVAL/INSTALLATION [MZI-3.7]** .)
3. Remove the engine cover. (See **ENGINE COVER REMOVAL/INSTALLATION [MZI-3.7]** .)
4. Remove the dynamic chamber (See **INTAKE-AIR SYSTEM REMOVAL/INSTALLATION [MZI-3.7]** .)
5. Remove in the order indicated in the table.

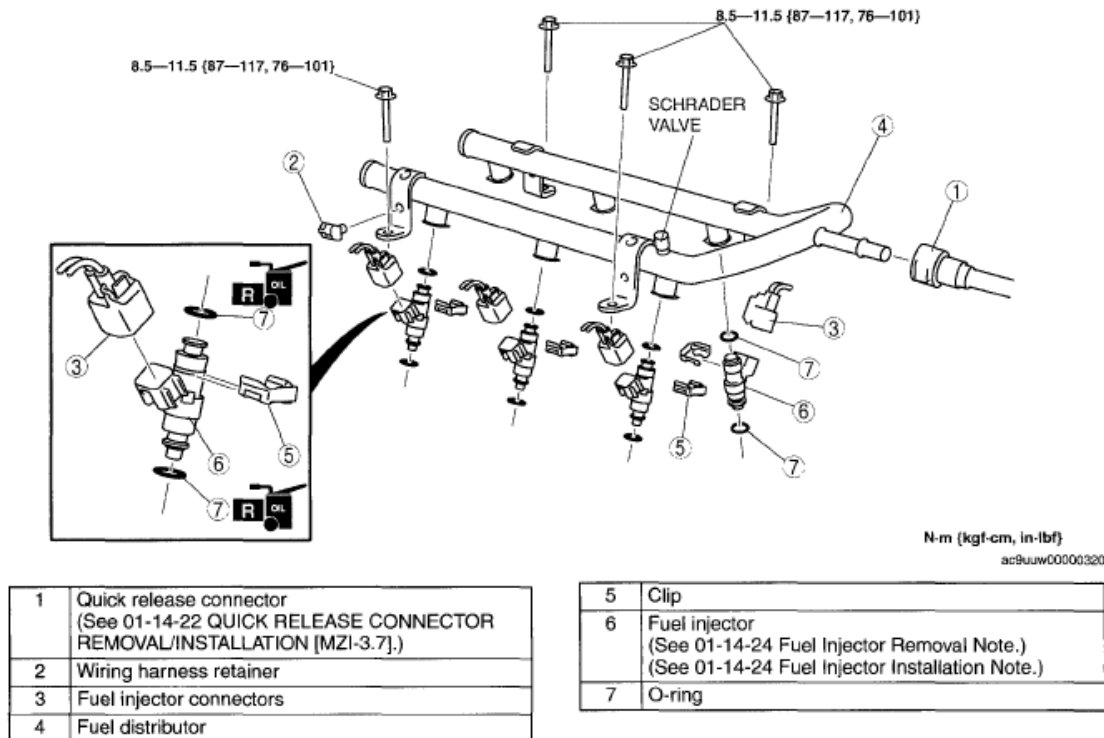

**Fig. 42: Identifying Quick Release Connector, Wiring Harness Retainer, Fuel Injector Connectors, Clip & Torque Specifications**

Courtesy of MAZDA MOTORS CORP.

6. Install in the reverse order of removal.



7. Complete the "AFTER SERVICE PRECAUTION". (See AFTER SERVICE PRECAUTION [MZI-3.7].)

**FUEL INJECTOR REMOVAL NOTE**

- CAUTION:**
- Use of a deformed injector retaining clip will cause the injector to not engage correctly. Always use a new clip when reattaching the injector, otherwise it may cause the injector to rotate.

1. Insert a screwdriver between the injector cup and the clip fingers.

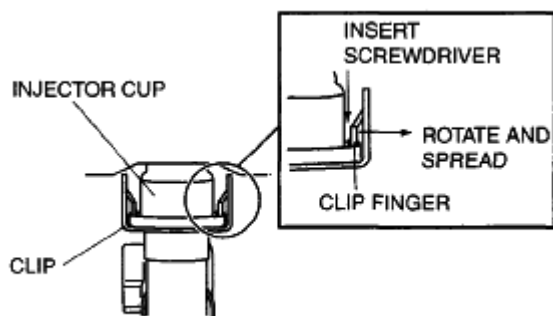

ac9uuw00001305

**Fig. 43: Identifying Injector Cup & Clip Fingers**  
 Courtesy of MAZDA MOTORS CORP.

- NOTE:**
- When rotating the screwdriver to spread the clip fingers, deform them sufficiently to make sure they release from the notched edge of the injector cup.

2. Rotate the screwdriver to spread the clip fingers and remove them from the injector cup.
3. Pull the injector and clip out of the rail.
4. Remove the clip from the injector according to the following:
  1. Grasp the clip with a pair of pliers.



ac9uuw00001306

**Fig. 44: Identifying Clip Fingers & Notch**

Courtesy of MAZDA MOTORS CORP.

2. Pull the clip parallel to the injector groove, and remove it from the injector.
3. Discard the clip.

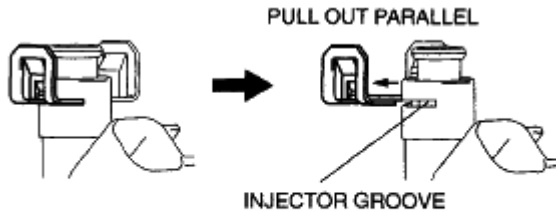

ac9uuw00001307

**Fig. 45: Pulling Clip To Injector Groove**  
Courtesy of MAZDA MOTORS CORP.

#### FUEL INJECTOR INSTALLATION NOTE

1. Install the new O-ring.
2. Lightly lubricate the injector groove and O-ring.
3. Pre-attach a new clip in the injector groove.

**NOTE:**

- When the clip is attached correctly, the central area of the injector and the clip finger positions are aligned.

4. Hold the injector firmly, push the clip into the injector until the clip stops sliding.
5. Verify that the injector connector position is correct, and press the injector and clip into the injector cup. Continue pressing until the clip contacts the lower surface of the injector cup.
6. Verify that the injector and clip are correctly attached with the clip locked onto the injector cup notch.

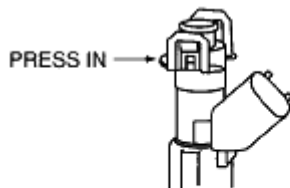

ac9uuw00001308

**Fig. 46: Pushing Clip Into Injector**  
Courtesy of MAZDA MOTORS CORP.

#### FUEL INJECTOR INSPECTION [MZI-3.7]

**NOTE:**           • Perform the following inspection only when directed.

### OPERATION TEST

1. Carry out the "Fuel Injector Operation Inspection". (See **ENGINE CONTROL SYSTEM OPERATION INSPECTION [MZI-3.7]** .)
  - If not as specified, perform the further inspection for the fuel injectors.

### RESISTANCE INSPECTION

1. Turn the ignition switch to LOCK position.
2. Disconnect the negative battery cable. (See **BATTERY REMOVAL/INSTALLATION [MZI-3.7]** .)
3. Remove the engine cover. (See **ENGINE COVER REMOVAL/INSTALLATION [MZI-3.7]** .)
4. Remove the dynamic chamber. (See **INTAKE-AIR SYSTEM REMOVAL/INSTALLATION [MZI-3.7]** .)
5. Disconnect the fuel injector connectors.
6. Measure the resistance of the fuel injector.
  - If not as specified, replace the fuel injector. (See **FUEL INJECTOR REMOVAL/INSTALLATION [MZI-3.7]**.)
  - If as specified but "Operation Test" is failed, carry out the "Circuit Open/Short Inspection". Inspect for open or short circuit.

### Fuel injector resistance

11-18 ohms

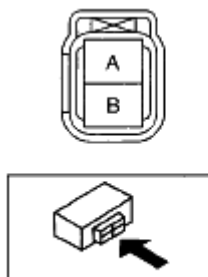

ac9uuw00901004

**Fig. 47: Identifying Fuel Injector Connectors**  
Courtesy of MAZDA MOTORS CORP.

### CIRCUIT OPEN/SHORT INSPECTION

1. Disconnect the PCM connector.
2. Inspect the following wiring harness for open or short (continuity check).

# 2008 Mazda CX-9 Grand Touring

2008 ENGINE Fuel System (MZI-3.7) - Mazda CX-9

FUEL INJECTOR  
WIRING HARNESS-SIDE CONNECTOR

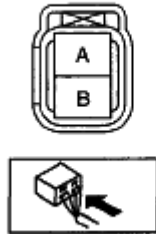

ac9uuw00001005

**Fig. 48: Identifying Fuel Pump Unit Wiring Harness-Side Connector**  
Courtesy of MAZDA MOTORS CORP.

MAIN FUSE BLOCK  
(FUEL PUMP RELAY)

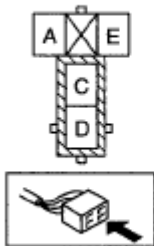

ac9uuw00001018

**Fig. 49: Identifying Main Fuse Block (Fuel Pump Relay)**  
Courtesy of MAZDA MOTORS CORP.

PCM  
WIRING HARNESS-SIDE CONNECTOR

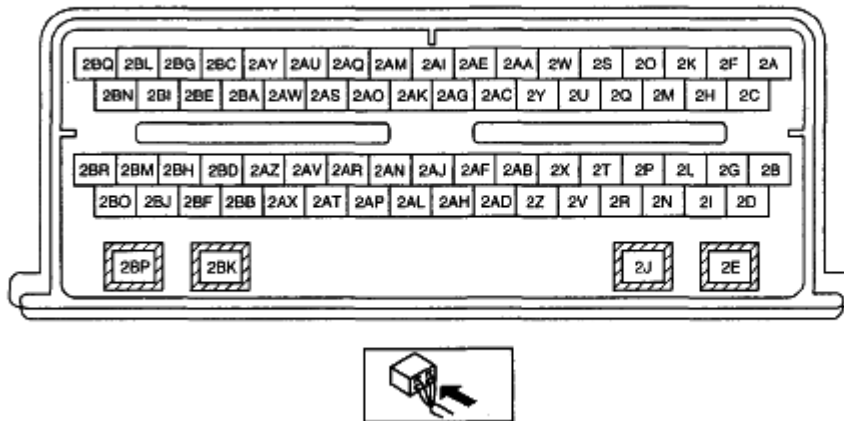

ac9uuw00001006

**Fig. 50: Identifying PCM Wiring Harness-Side Connector**  
Courtesy of MAZDA MOTORS CORP.

Open circuit

- If there is no continuity, the circuit is open. Repair or replace the harness.
  - No.1 cylinder fuel injector terminal A and PCM terminal 2BJ
  - No.2 cylinder fuel injector terminal A and PCM terminal 2BM
  - No.3 cylinder fuel injector terminal A and PCM terminal 2BF
  - No.4 cylinder fuel injector terminal A and PCM terminal 2BH
  - No.5 cylinder fuel injector terminal A and PCM terminal 2BB
  - No.6 cylinder fuel injector terminal A and PCM terminal 2BD
  - No.1 cylinder fuel injector terminal B and fuel pump relay terminal D
  - No.2 cylinder fuel injector terminal B and fuel pump relay terminal D
  - No.3 cylinder fuel injector terminal B and fuel pump relay terminal D
  - No.4 cylinder fuel injector terminal B and fuel pump relay terminal D
  - No.5 cylinder fuel injector terminal B and fuel pump relay terminal D
  - No.6 cylinder fuel injector terminal B and fuel pump relay terminal D

### **Short circuit**

- If there is continuity, the circuit is short. Repair or replace the harness.
  - No.1 cylinder fuel injector terminal A and body ground
  - No.2 cylinder fuel injector terminal A and body ground
  - No.3 cylinder fuel injector terminal A and body ground
  - No.4 cylinder fuel injector terminal A and body ground
  - No.5 cylinder fuel injector terminal A and body ground
  - No.6 cylinder fuel injector terminal A and body ground
  - No.1 cylinder fuel injector terminal B and power supply
  - No.2 cylinder fuel injector terminal B and power supply
  - No.3 cylinder fuel injector terminal B and power supply
  - No.4 cylinder fuel injector terminal B and power supply
  - No.5 cylinder fuel injector terminal B and power supply
  - No.6 cylinder fuel injector terminal B and power supply

### **ATOMIZATION**

1. Inspect atomization pattern.
  - If the atomization is faulty, replace the fuel injector. (See **FUEL INJECTOR REMOVAL/INSTALLATION [MZI-3.7].**)

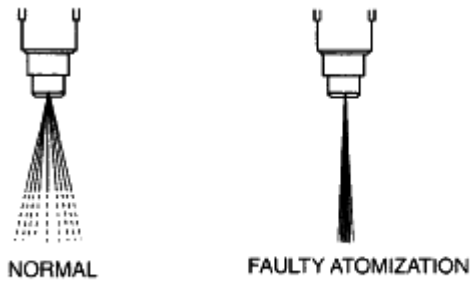

am8rrw00001725

**Fig. 51: Inspecting Atomization Pattern**  
Courtesy of MAZDA MOTORS CORP.

## PRESSURE REGULATOR INSPECTION [MZI-3.7]

**NOTE:**

- Due to the adoption of the mechanical returnless fuel system, the pressure regulator cannot be inspected separately.

1. Perform "FUEL LINE PRESSURE INSPECTION". (See **FUEL LINE PRESSURE INSPECTION [MZI-3.7].**)